

USER MANUAL CHARGING STATIONS AC

TABLE OF CONTENTS

GENERAL INFORMATION AND WARRANTY	3
ASSEMBLY INSTRUCTIONS	4
CABLING INSTRUCTIONS	5
ADDITIONAL INFORMATION	6
PRODUCT DESCRIPTION	10
FREE MODE	12
PERSONAL MODE	14
NET OPERATION (OCPP)	18
ERRORS	29
CARD PROGRAMMER	31
POWER MANAGEMENT (OPTIONAL)	34
MAINTENANCE AND ASSISTANCE	37



GENERAL INFORMATION

Scame charging stations use the mode 3 charging technique (as per IEC/EN 61851-1 standard), which involves connecting an electrical or hybrid vehicle to a power network in AC using specific connectors (as per standards IEC/EN 62196-1 and 2).

- This manual contains warnings and instructions that must be followed for the installation, use and maintenance of the charging station and which must be available for consultation by authorised personnel.
- Station installation and start-up, together with maintenance operations, must be carried out by qualified and specifically authorised personnel in compliance with current safety standards, regulations and legislation.
- The manufacturer of the station shall not be held liable for any damage to persons, animals and/or property resulting from failure to comply with the instructions in this manual.
- Given that improvement is continuous, we reserve the right to make changes to the product and this manual at any time.
- The total or partial reproduction of this manual without the prior consent of Scame Parre S.p.A. is prohibited.



HAZARD: Risk of electrical shock, explosion or electric arcs

- Prior to performing any operations on the charging station, disconnect the power and use suitable tools to check that the power is disconnected from all parts.
- Before starting up the station, check that the metal structure is earthed by way of the yellow-green conductor and protect the power line using an automatic safety device and differential switch coordinated with the grounding system.
- Before connecting the vehicle to the station, make sure it is firmly secured.
- Power cables, sockets and plugs used to connect the vehicle must comply with safety requirements laid down by current legislation.
- It is prohibited to use extension cords to connect the vehicle.
- Failure to comply with safety precautions may cause serious injury and even death.



CAUTION: Risk of damaging the station

- Do not touch the printed circuit boards and/or use suitable instruments when accessing components/ parts subject to electrostatic discharges.
- If necessary due to the environmental conditions, install devices to protect against atmospheric discharges in the upstream power distribution board (e.g. surge arrester type 2, $U_p = 1.5 \text{ kV}$, $I_n = 20 \text{ kA}$).
- If the station is damaged it should not be installed or used.
- To clean, use a damp cloth or neutral detergent compatible with plastic.

WARRANTY

- The charging station referred to by this manual is covered by a two-year manufacturer's warranty in accordance with the Consumer Code (articles 128 and following), which includes reimbursement, necessary repairs or replacement to rectify any manufacturing defects encountered during normal use for a period of 24 months from the date of delivery of the product.
- Any modifications to the station, or installations and start-ups not compliant with the instructions reported in this manual shall result in the nullification of the warranty and the invalidation of the product certificates.

ASSEMBLY INSTRUCTIONS

FLOOR STANDING STATIONS

- Floor standing charging stations are supplied pre-assembled (body and base).
- The body is secured to the base using #4 M12 threaded rods and corresponding bolts, which in the case of two-stage installations can be disassembled to allow the base alone to be anchored to the floor.
- The base may be anchored to the floor using the cramp iron kit (optional) to be embedded in concrete, or by means of #4 rawlplugs (not included).
- The cramp iron kit contains a plate with #4 M8 J-shaped threaded rods (L=210mm).

WALL STATIONS

- Wall charging stations are supplied assembled (base and cover).
- Access the internal compartment by removing the shutter to secure the station. Follow the instruction sheet to secure.
- For drilling, observe the measurements on the instruction sheet (included).

POLE STATIONS (OPTIONAL)

- Anchor the pole to the floor using #4 rawlplugs (not included) and secure the plate to the pole using the supplied collars.
- Secure the station in the same way as wall mounting on the plate.

FOR COMPLETE ASSEMBLY INSTRUCTIONS SEE INSTRUCTION SHEETS (INCLUDED)

INSTALLATION IN AREAS NOT DIRECTLY EXPOSED TO THE SUN IS RECOMMENDED. USE SUITABLE SUPPORTS.

CABLING INSTRUCTIONS

SYSTEM REQUIREMENTS

- Check the following electrical values:
 - ◇ Grounding system: TT, TN(S), TN(C),
 - ◇ Phase to phase voltage (L-L): between 380 and 400Vac inclusive
 - ◇ Phase to neutral voltage (L-N): between 220 and 230Vac inclusive
 - ◇ Neutral to ground voltage (N-PE): less than 5Vac
 - ◇ Frequency (f): 50 or 60Hz
 - ◇ Ground resistance (Rt): less than 50Ω
 - ◇ Total Harmonic Distortion (THD): less than 8%
- Other values may compromise charging.

POWER LINE

- The stations have spaces provided for cable entry: drill holes and install cable glands as indicated on the instruction sheet (included).
- The stations have terminal blocks for cable connections: connect phase, neutral and earth conductors as shown in the wiring diagram (included).
- Create the power line using conductors of suitable cross-section for the load

Power (kW)	Voltage (V)	Current (A)	Cable section (mm ²)	Max lenght (m)
3,7	230	16	3G4	50
7,4	230	32	3G6	40
11	400	16	5G4	100
22	400	32	5G6	80
44	400	63	5G16	100

Values determined considering FG7OR 0.6/1kV and <4% voltage drop

The designer of the electrical system is solely responsible the sizing of the power line.

ADDITIONAL INFORMATION

MAX0: control board

SW1: reboot button.

- Short press to restart the station.
- Prolonged pressure (> 20S) causes the board to be reset to the default configuration with controls disabled.

Warning: the default configuration is to be used only in an emergency and may not work correctly on some versions, the original configuration must be restored as soon as possible.

SW2: selector for maximum deliverable current

- 0: 6A, 1: 10A, 2: 13A, 3: 16A, 4: 20A, 5: 25A, 6: 32A, 7: 40A, 8: 50A, 9: 63A

SW4: counter serial termination resistor selector

SW5: NET serial termination resistor selector

IN1-GND: remote enabling contact.

- If closed, it suspends the charge in progress or inhibits a new charge.
- If open, it resumes charging in progress or allows a new charge.

PCX0 - SBC0: local server with OCPP protocol (Optional)

- Remote management device

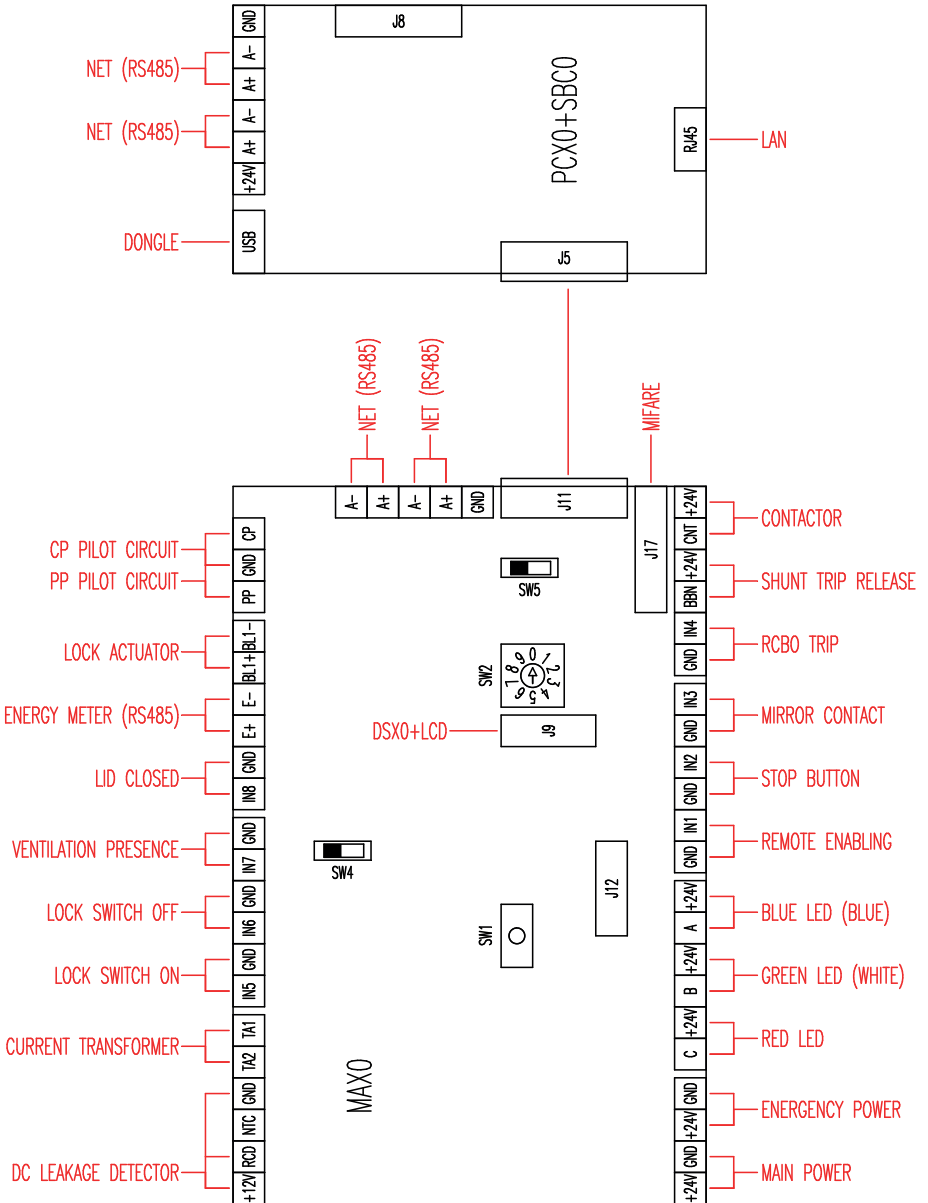

SCU: control board

SW1: reboot button.

- Short press to restart the station.
- Prolonged pressure (> 20S) causes the board to be reset to the default configuration with controls disabled.

Warning: the default configuration is to be used only in an emergency and may not work correctly on some versions, the original configuration must be restored as soon as possible.

CN8: selector for maximum deliverable current

- 0: 6A, 1: 10A, 2: 13A, 3: 16A, 4: 20A, 5: 25A, 6: 32A, 7: 40A, 8: 50A, 9: 63A

AB-REM: remote enabling contact

- If closed, it suspends the charge in progress or inhibits a new charge.
- If open, it resumes charging in progress or allows a new charge.

SBC-LAN: local server with OCPP protocol (Optional)

- Remote management device

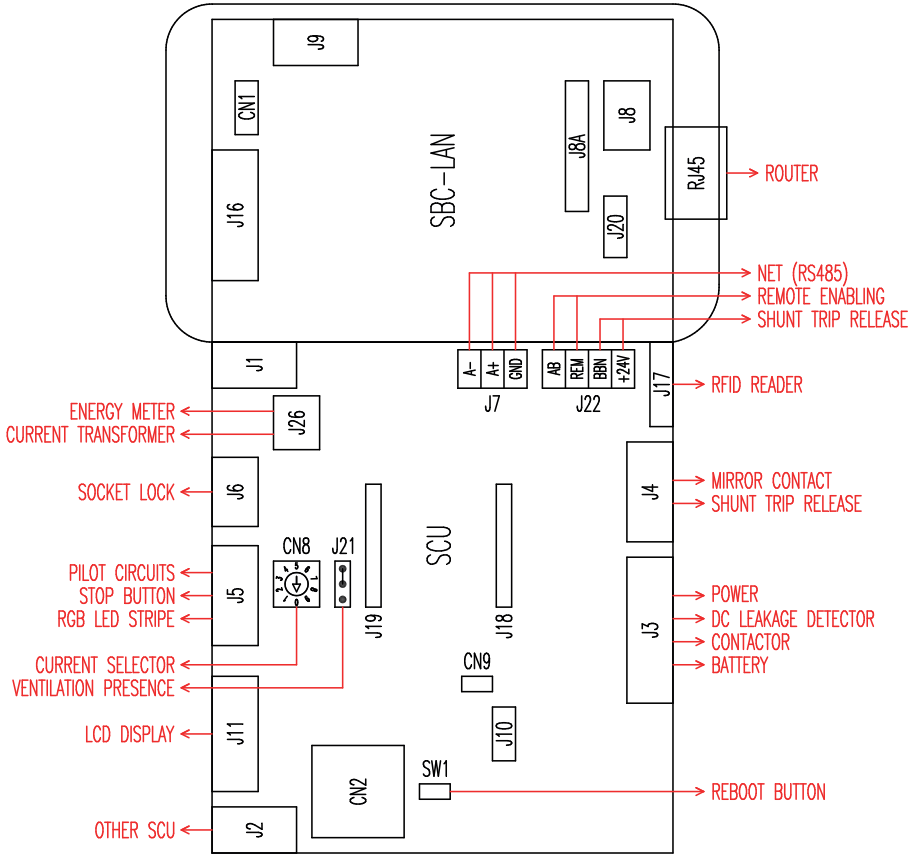

PRODUCT DESCRIPTION

Depending on the version, the stations can be equipped with:

1. **Display (multi-language).**
2. **RFID reader (Mifare Classic or Mifare Plus).**
3. **LED (LED pair or RGB strip)**
4. **Button:**
 - Change language (press when charging point is not in use).
 - Consumption display (long press when charging point is not in use. Only with energy meters).
 - Charging interrupted (press during charging in free mode).
5. **Sockets:**
 - Picoblade connector with cable (e.g. type 1 and type 2).
 - Without blocks (e.g. type 3A and UNEL).
 - With plug block (e.g. type 2).
 - With plug block/shutter (e.g. type 3A, type 2 and UNEL).

Depending on the version, the stations can have the following operating modes:

- FREE: user identification not necessary.
- PERSONAL: user identification necessary.
- NET: required user identification and remote management

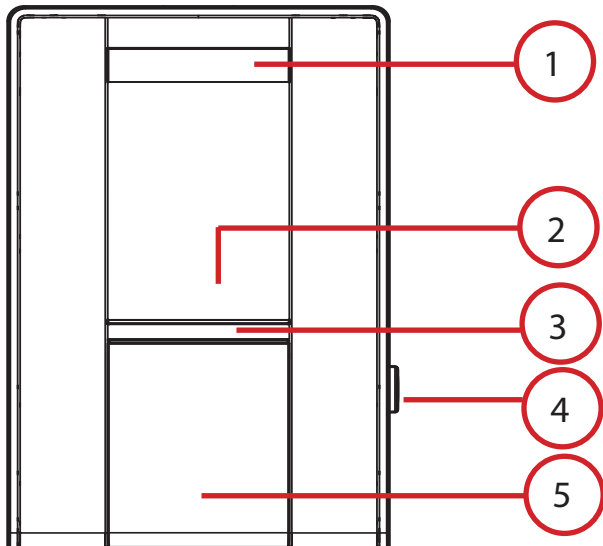
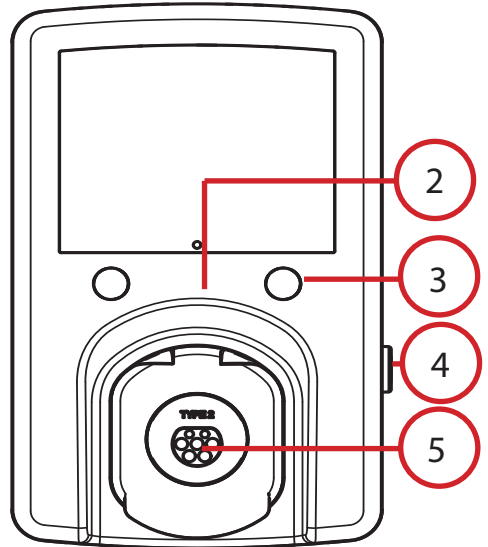
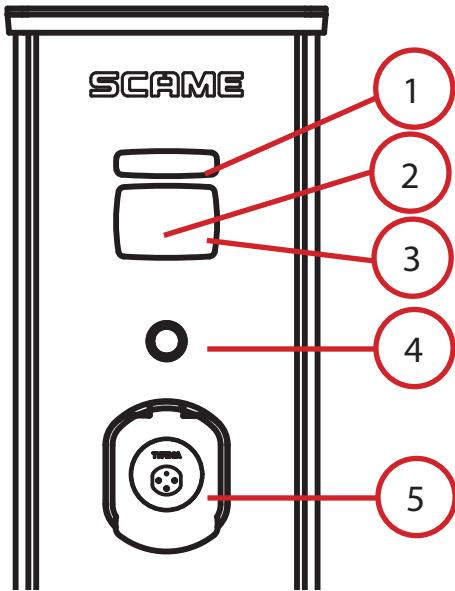

FREE MODE

STATION ACCESSIBLE TO ANYONE WITH NO RECOGNITION

Stations CA, CB, WB, UB

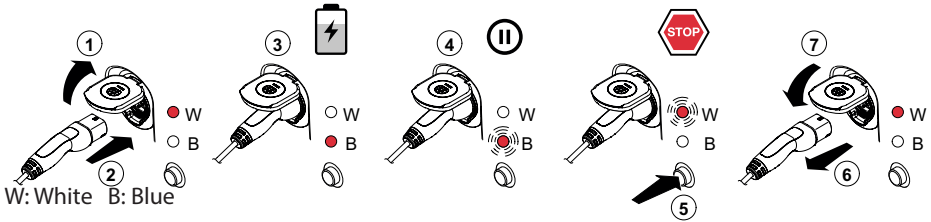

Stations BE-W, BE-A, BE-B, WD

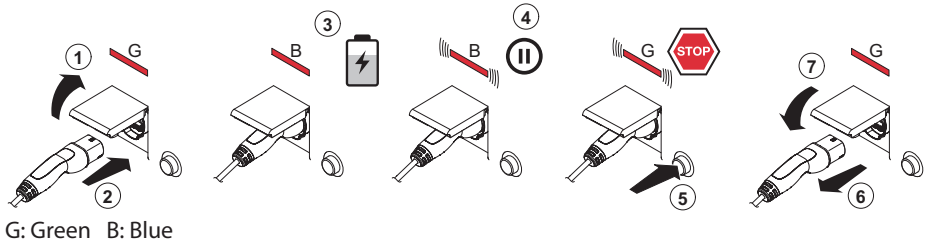

NB: Disconnection of the cord-set from the station is mandatory following charging. To begin a new charging session, re-connect the cord-set to the station.

CHANGE MODE

- Terminate charging in progress
- Press and hold the stop button and simultaneously present the **MASTER CARD** (red) to the RFID reader to change mode
- Repeat the procedure to return to the previous mode.

Status	LED Pair	RGB LED	Display (if included)
Station not powered	× ×	×	×
Supply power to station	× (((●)))	(((●)))	SCAME PARRE (firmware release)
Station powered	○ ×	●	SOCKET AVAILABLE
Insert plug in socket	○ ×	●	PLUG INSERTED
Connect vehicle	× (((●)))	(((●)))	WAITING FOR EV
If vehicle needs charging	× ●	●	CHARGING (calibration) (current)(power)(time)
If vehicle does not need charging	× (((●)))	(((●)))	SUSPENSION (current)(power)(time)
If station suspends charging	× (((●)))	(((●)))	WAITING FOR RM (time)
Press button	(((○))) ×	(((●)))	REMOVE PLUG
Remove plug	○ ×	●	SOCKET AVAILABLE

× = off ○ - ● - ● = steady light (((○))) - (((●))) - (((●))) = flashing light

PERSONAL MODE

STATION WITH RESTRICTED ACCESS VIA USER CARD

Stations CA, CB, WB, UB

USER CARD

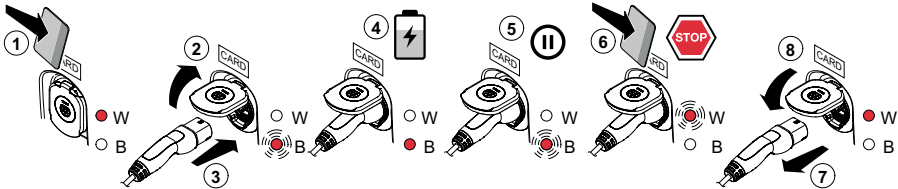

W: White B: Blue

Stations BE-W, BE-A, BE-B, WD

USER CARD

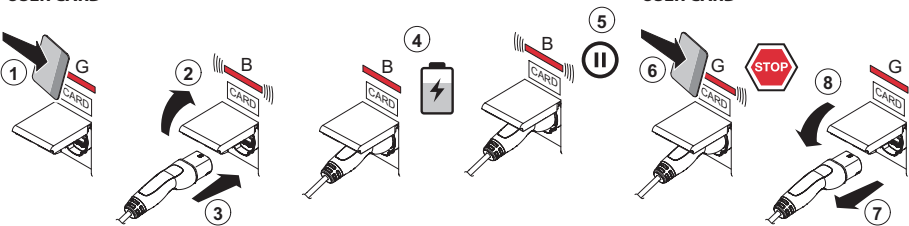

G: Green B: Blue

NB: Disconnection of the cord-set from the station is mandatory following charging. To begin a new charging session, re-connect the cord-set to the station.

CHANGE MODE

- Terminate charging in progress
- Press and hold the stop button and simultaneously present the **MASTER CARD** (red) to the RFID reader to change mode
- Repeat the procedure to return to the previous mode.

Status	LED Pair	RGB LED	Display (if included)
Station not powered	× ×	×	×
Supply power to station	× (((●)))	(((●)))	SCAME PARRE (firmware release)
Station powered	○ ×	●	CARD PRESENT
Present card	× (((●)))	(((●)))	INSERT PLUG
Insert plug in socket	× (((●)))	(((●)))	PLUG INSERTED
Connect vehicle	× (((●)))	(((●)))	WAITING FOR EV
If vehicle needs charging	× ●	●	CHARGING (calibration) (current)(power)(time)
If vehicle does not need charging	× (((●)))	(((●)))	SUSPENSION (current)(power)(time)
If station suspends charging	× (((●)))	(((●)))	WAITING FOR RM (time)
Present card	(((○))) ×	(((●)))	REMOVE PLUG
Remove plug	○ ×	●	CARD PRESENT

× = off ○ - ● - ● = steady light (((○))) - (((●))) - (((●))) = flashing light

USER MANAGEMENT

PRESENT NEW USER CARDS

- With the station in PERSONAL mode
(display: PM PRESENT CARD)
- Show the master card on the RFID reader to enter programming mode
(display: DATABASE MANAGEMENT – PRESENT CARD)
- Show the user card on the RFID reader to be inserted into the memory
(display: ID REGISTER – 001 USERS)
- Show all user cards to be inserted into the memory or close database management presenting the master card or allowing countdown to terminate

USER CARD DELETION

- With the station in PERSONAL mode
(display: PM PRESENT CARD)
- Show master card on the RFID reader to enter programming mode
(display: DATABASE MANAGEMENT – PRESENT CARD)
- Show the user card on the RFID reader to be deleted from the memory
(display:DELETE USER?)
- Show the same user card on the RFID reader to confirm deletion (display:ID DELETED–000 USERS)
- Show all user cards to be deleted from the memory or close database management presenting the master card or allowing countdown to terminate

NET OPERATION (OCPP)

REMOTELY MANAGED STATION

- **NET:** list of authorised users included in the local server memory
- **OCPP:** list of authorised users included in the central station memory

CONNECTION INSTRUCTIONS

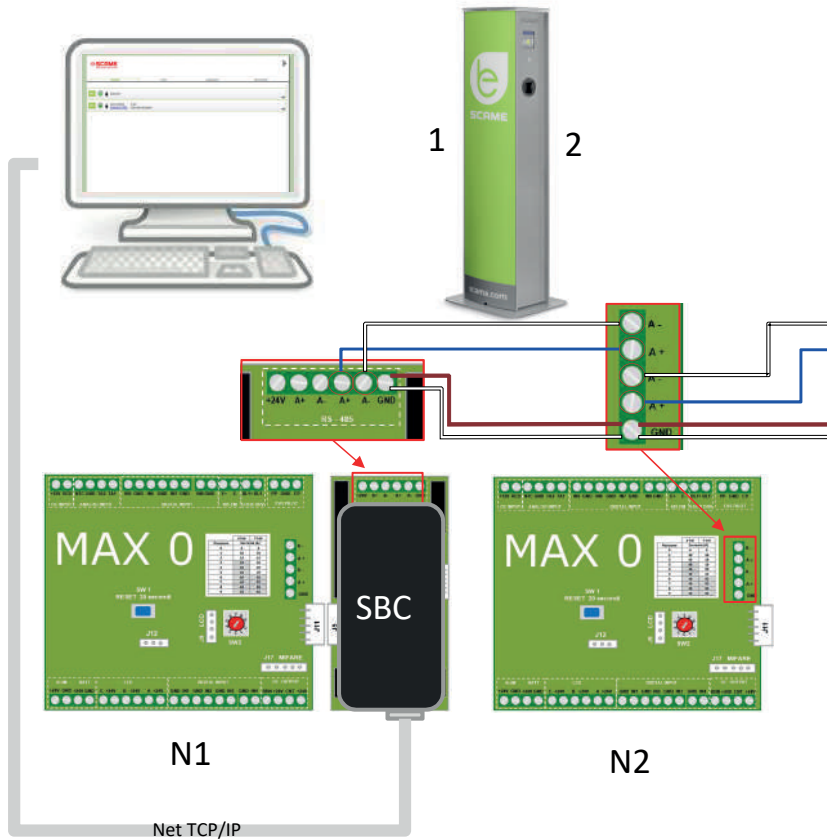



NETWORK CABLE TYPE F/UTP
CAT6 IN SEPARATE TUBE
Mutual Capacitance < 10 pF/m
Capacitance Unbalance < 60 pF/m
Blue/White pair:
Blue: A+
White: A-
Brown/White pair:
Brown: GND
White: GND

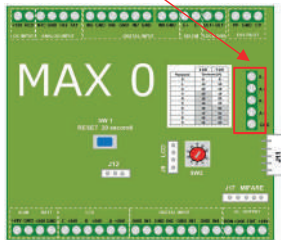
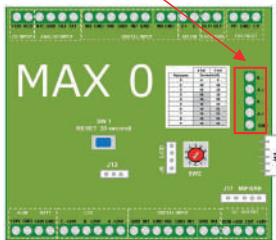
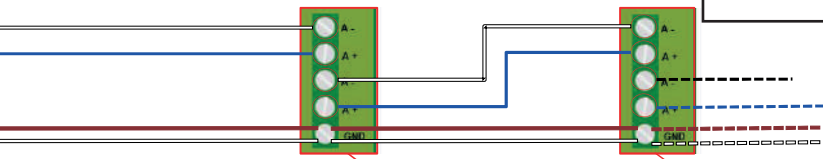

Maximum of 16 addresses for each Master station

USER INSTRUCTIONS

The Scame management system does not require any software installation. Simply access via browser like a normal web page.
(Internet Explorer, Google Chrome, Firefox,...)

In the event of unsafe networks, an encrypted connection may be enabled (HTTPS protocol).

To connect to the control system, you need to:

- Connect the master station to the computer or to a local network via ETHERNET port or Wi-Fi (if present).
- Connect the RS485 serial line from the slave stations to the master station (up to 16 charging points).
- Via web browser, access the server's IP address (default address: 192.168.30.126; **username: admin; password: gsroot**)

SUMMARY OF STATIONS

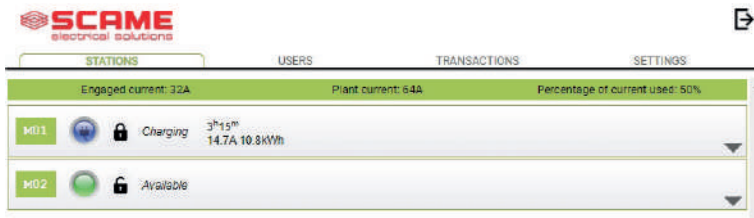

The screen displays the status of the sockets in real time:

- If the socket is not in use, "Available" is displayed.
- If the socket is in use, the following are displayed: "Charging", the user who is using it, charging duration, the energy drawn and the instantaneous current.
- If there is no communication between station and server, "Disconnected" is displayed.
- if there is a fault, the error is displayed

SOCKETS IN DETAIL

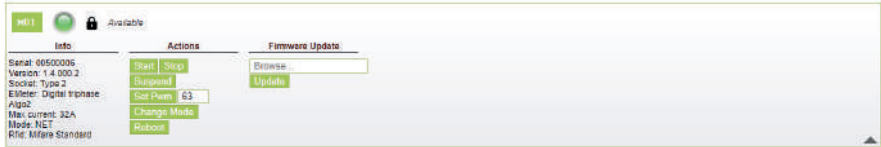

By clicking on the arrow at the bottom right, more detailed information can be viewed and commands sent.

The following information is displayed:

- **Serial:** serial number of the controller board
- **Version:** version of the firmware controlling the socket
- **Socket:** technical name of the socket
- **EMeter:** type of current measuring system
- **Max Current:** maximum current output of socket (A)
- **Mode:** Socket operating mode
 - ◇ **FREE:** free access
 - ◇ **NET:** access with authorisation (RFID card)
- **RFID:** type of RFID reader installed

The socket can be controlled using the following commands:

- **Start:** authorises charging (works only if the socket is in **NET** mode)
- **Stop:** starts the charging interruption process
- **Suspend/Resume:** interrupts/resumes the current output without interrupting the charging session (the connector is locked in the socket)
- **Set Pwm:** limits the maximum value of current output supplied to the vehicle (integer values between 6 A and 63 A. The maximum value of current output supplied will not exceed the flow limit of the socket and/or the cord-set.)
- **Change Mode:** changes the socket operating mode (**FREE** or **NET**)
- **Reboot:** reboots the electronics controlling the socket.
- **Update Firmware:** updates the firmware of the electronics controlling the socket

USERS



STATIONS

USERS

TRANSACTIONS

SETTINGS



User	Card	Scalar	Expire	Enabled
TEST1	7138C2B9000000			true
TEST2	858383D3000000		2021-01-30	true
TEST3	E4F032B0000000	9		true
TEST4	4EC607ED000000			true

Add User

The **USERS** screen displays user data and access settings for the charging service, which may be changed by clicking on the name link (User column).

A new user may be added using “Add User” button.

EDIT USER

STATIONS **USERS** TRANSACTIONS SETTINGS

X

User:

Card:

Vehicle:

Phone:

E-mail:

Scalar:

Expire:

Enabled:

Delete Save

[Transactions >](#)

On this display it is possible to:

- Enter or change user data.
- Enable or disable the user card or modify it according to the maximum number of charges and/or an expiry date.
- Delete a user from the control system.
- Display the data of all charges carried out by the user by clicking the link **"Transactions>"**.

TRANSACTIONS



STATIONS

USERS

TRANSACTIONS

SETTINGS

Id	Connector	User	State	Error	Start	Stop	Duration	kWh
62	2	TEST1	open		2020/09/15 10:35:43		3m	0.0
61	2	TEST4	canceled	timeout	2020/09/15 10:34:53	2020/09/15 10:04:58	0m	0
60	1	FREE	open		2020/09/15 06:45:48		3h 25m	11.4
59	1	FREE	closed	CPLS	2020/09/14 13:10:08	2020/09/14 13:10:47	0m	0
58	1	FREE	closed	CPLS	2020/09/14 13:09:25	2020/09/14 13:09:57	0m	0
57	2	FREE	closed		2020/09/14 11:54:36	2020/09/14 17:10:02	5h 15m	10
56	2	FREE	closed		2020/09/14 06:34:58	2020/09/14 11:01:41	4h 26m	20.7
55	1	FREE	closed	CPLS	2020/09/14 06:26:29	2020/09/14 13:09:05	6h 42m	15.8
54	1	FREE	closed	CPLS	2020/09/11 06:54:32	2020/09/11 18:00:55	9h 6m	29.4
53	2	FREE	closed	CPLS	2020/09/11 06:38:50	2020/09/11 12:18:59	6h 10m	44.8

All Transactions

The **TRANSACTIONS** displays all transaction data, monitoring the duration of each charge and the power output of each socket.

All transactions will appear by clicking on **ALL TRANSACTIONS**.

It is also possible to filter by user (by clicking on the [name](#) link) and exporting the data in CSV format (compatible with Excel) by clicking "save transactions".

CONFIGURATION



STATIONS	USERS	TRANSACTIONS	SETTINGS
▶ Network Setup			
▶ OCPP Type Selector			
▶ OCPP 1.5 Setup			
▶ OCPP 1.5 Configurations			
▶ Load Balancing			
▶ Advanced Setup			

This screen allows configuration of the system settings.

NETWORK CONFIGURATION

▼ Network Setup

IP Address	<input type="text" value="192.168.30.126"/>
Net Mask	<input type="text" value="255.255.255.0"/>
Gateway	<input type="text" value="192.168.30.1"/>
DNS	<input type="text" value="8.8.8.8"/>
Hostname	<input type="text" value="SCMSRV0000"/>

This section allows the setting of the network configuration parameters of the SBC, indicating to which IP address the web page of the control system will stay connected.

OCPP SETTINGS

OCPP 1.5 Setup

OCPP Enabled	<input type="checkbox"/>
Central Station IP Address	<input type="text"/>
Accepts messages only from the above IP address	<input type="checkbox"/>
Central Station TCP Port	<input type="text"/>
Central Station Path	<input type="text"/>
Charge Box TOP Local Port	<input type="text" value="82"/>
Charge Box Path	<input type="text" value="/cp"/>
Charge Box Public IP Address (*)	<input type="text"/>
Charge Box Public IP auto detection (*) If on, the value of previous parameter is overridden!	<input type="checkbox"/>
Charge Box Public TCP Port	<input type="text" value="82"/>
Charge Box Identity	<input type="text"/>
SIM Card Serial Number (ICCID)	<input type="text"/>
SIM Card PIN (MSI)	<input type="text"/>

Save

OCPP 1.5 Configurations

BlinkRepeat	<input type="text" value="0"/>
ChargePointId	<input type="text" value="n/a"/>
ClockAlignedDataInterval	<input type="text" value="0"/>
ConnectionTimeOut	<input type="text" value="60"/>
HeartBeatInterval	<input type="text" value="60"/>
LightIntensity	<input type="text" value="0"/>
MeterValuesAlignedData	<input type="text" value="n/a"/>
MeterValuesSampledData	<input type="text" value="Energy Active.Import.Regist"/>
MeterValuesSampleInterval	<input type="text" value="300"/>
ProximityContactRetries	<input type="text" value="0"/>
ProximityLockRetries	<input type="text" value="0"/>
ResetRetries	<input type="text" value="0"/>
StopTxnAlignedData	<input type="text" value="0"/>
StopTxnSampledData	<input type="text" value="0"/>
PwmMode	<input type="text" value="1:63"/>
scene_NotifyFaultStatusOnEvents	<input type="text" value="false"/>
scene_EnableThreePhaseMeterValues	<input type="text" value="false"/>
scene_MeterValuesCompactFormat	<input type="text" value="false"/>

Save

In these sections the parameters can be set and configured to establish connection via OCPP 1.5 SOAP to a CENTRAL STATION. Refer to the central station owner and the official OCPP document to populate the fields.

LOAD BALANCING (OPTIONAL)

▼ Load Balancing

Algorithm	Democratic Static ▼
Minimum socket current	6
Maximum plant current	64

Save

In this section it is possible to specify the load balancing algorithm that will be applied to the sockets controlled by the control system. To disable load balancing, select none in the “Algorithm” field.

The Static Democratic algorithm distributes the available current equally in the system to all connected sockets. If the system’s maximum current is not sufficient to allow simultaneous charging across all sockets, new charging sessions will be suspended (connector blocked but with no power output). The system is able to detect when a vehicle has finished charging and therefore redirect its share of the current to the other sockets, or resume any suspended charging sessions.

For correct operation, all sockets must be connected to one dedicated electrical power supply only.

The “Minimum socket current” field contains the value (integer value) of the electric current (in amperes) below which vehicle charging will be suspended (each vehicle has a minimum current value, below which it cannot be charged).

In the field “Maximum system current”, the value (integer value) of the current (A) dedicated to the charging systems must be entered. Inserting a value that is higher than the current that is actually available may trigger the line’s protection systems.

ADDITIONAL SETTINGS

▼ Advanced Setup

Date/Time	<input type="text" value="2020/09/15 11:58:28"/>	<input type="button" value="Save"/>
Language	<input type="text" value="English"/>	<input type="button" value="Save"/>
Update Configuration	<input type="button" value="Scogli file"/> Nessun ...zionato	<input type="button" value="Update"/>
Software Version	<input type="text" value="1.3.3"/>	
Software Update	<input type="button" value="Scogli file"/> Nessun ...zionato	<input type="button" value="Update"/>
Reset Software	<input type="button" value="Reset"/>	
Reboot SBC	<input type="button" value="Reboot"/>	
HTTPS Web interface Enabled	<input type="checkbox"/>	<input type="button" value="Save"/>

In this section the date and system language can be set, updates installed and the software or the SBC operating system restarted.

ERRORS

Display (if included)	LED Pair	RGB LED	Cause/Solution
x	x x	x	The station is not powered. Check for voltage.
RCBO FAULT	x x	●	Protection triggered. Check vehicle, reset switch and restart station.
MIRR FAULT	x x	●	Overlapping contacts found. Check contactor, reset switch.
CPLS FAULT	(((○))) x	(((●)))	Pilot circuit open. Vehicle disconnected or check cord-set.
CPSE FAULT	(((○))) x	(((●)))	Pilot circuit fault. Check cord set.
PPLS FAULT	(((○))) x	(((●)))	Plug presence open. Plug disconnected or check cord-set.
PPSE FAULT	(((○))) x	(((●)))	Plug presence fault. Check cord set.
BLCK FAULT	(((○))) x	(((●)))	Plug block not in position. Plug not inserted correctly or check operation of block actuator.
OVCE FAULT	(((○))) x	(((●)))	Power draw higher than the maximum set current detected. Check vehicle.
VENT FAULT	(((○))) x	(((●)))	Vehicle requiring ventilation detected. Bridge contact IN7-GND if present or if natural ventilation.
RCTE FAULT	(((○))) x	(((●)))	Pilot circuit control diode absent. Check vehicle.
PEN FAULT	(((○))) x	(((●)))	Abnormal voltage detected. Check mains power supply.

ERRORS

Display (if included)	LED Pair	RGB LED	Cause/Solution
EMTR FAULT	(((○))) ×	(((●)))	No communication with digital energy meter. Check meter operation or for any disturbances on serial line.
RCDM FAULT	(((○))) ×	(((●)))	Earth leakage detected with continuous component greater than 6 mA. Check vehicle.
NO VOLTAGE (timer)	(((○))) ×	(((●)))	No voltage during charging. If voltage returns within 3 minutes, charging resumes, otherwise it ends (with auxiliary battery only).
REMOVE PLUG	(((○))) ×	(((●)))	Plug inserted without prior authorisation. Remove plug and present an authorised card.
UNAUTHORISED USER	(((○))) ×	(((●)))	Unknown or unauthorised card code. Add or authorise the new code in the control system.
CLOSE SHUTTER	○ ×	●	Shutter closure failure detected. Close shutter or check switch operation.
MFRE FAULT	○ ×	●	No communication with RFID reader. Check reader operation or presence of disturbances on serial line.
CLKE FAULT	○ ×	●	Date and time not set.

× = off ○ - ● - ● = steady light (((○))) - (((●))) - (((●))) = flashing light

CARD PROGRAMMER (208.PROG2)

PROGRAMMER SOFTWARE – For Microsoft Windows 7, 8, 10 operating systems only

- Before connecting the programmer to the computer, download the application software 208Prog2_V1.zip from the download area of our website <https://e-mobility.scame.com/download>.
- Install the software by launching the program 208Prog2Installer_V1.exe.
- Except for special needs, it is advisable to accept the proposed selections and to install the drivers (if it is not possible to install the drivers, continue anyway).
- Connect the programmer to a USB port on the computer.

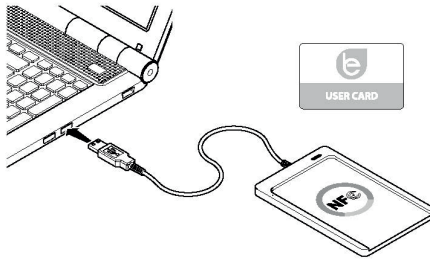

- Run the program 208Prog2_V1.exe; the following screens will be displayed:

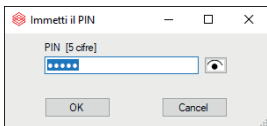

- Enter unauthorized write lock PIN (optional, 5 digits, default 00000)



- Check that the programmer is correctly connected (see the green box in the bottom left corner).
- Select the desired language from the OPTIONS menu.

USER CARD PROGRAMMER

- Place the user card on the programmer; the following screen will be displayed:

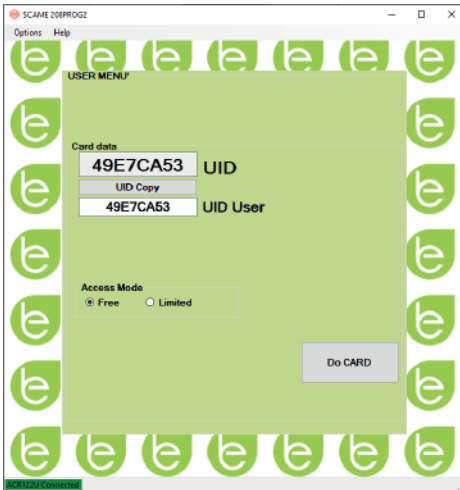

- To change the card code (optional): Edit the UID field, entering 8 hexadecimal digits of your choice (e.g. AAAA0001).
- To create a card without restrictions, leave the FREE access type selected.
- Click on the CREATE CARD button; a short beep will confirm the creation of the card.

- To activate the restrictions, select the LIMITED access type; the following screen will be displayed:



- To activate one of more restrictions, flag the relative field.
- To change the parameter, click on the arrows.
- Leave the field empty if you do not want to activate the relative restriction.
- Click on the CREATE CARD button; a short beep will confirm the creation of the card (energy and time limits can be set of for firmware versions 1.4.020 or later)

MASTER CARD PROGRAMMER

- Place the master card on the programmer; the following screen will be displayed:



- To set the date and time at the station, select DATE TIME.
- To delete the user cards stored in the station, select DELETE LIST
- Click on the CREATE CARD button; a short beep will confirm the creation of the card.
- Swipe the master card on the station reader to confirm the setting.

POWER MANAGEMENT (OPTIONAL)

The POWER MANAGEMENT function allows the charging current of the electric vehicle to be automatically modulated based on the user's contracted power and the power used by the dwelling (e.g. washing machine, TV, oven, etc.) in order to prevent untimely tripping of the meter.

WARNING

In the event that the available power is not sufficient, the station will suspend any charging in progress and will resume it when possible.

It should be noted that there are electric vehicles on the market that are not compatible with this function, therefore the "wake up" procedure implemented in the station (according to standard IEC/EN 61851-1) has no effect.

These vehicles may remain in "sleep" mode and may not resume charging unless they are disconnected from the station or other unblocking operations are performed (it is advisable to refer to the manual supplied with your car).

INSTALLATION

The station comes with an additional energy meter, already configured, to be installed as follows:

SINGLE-PHASE STATION

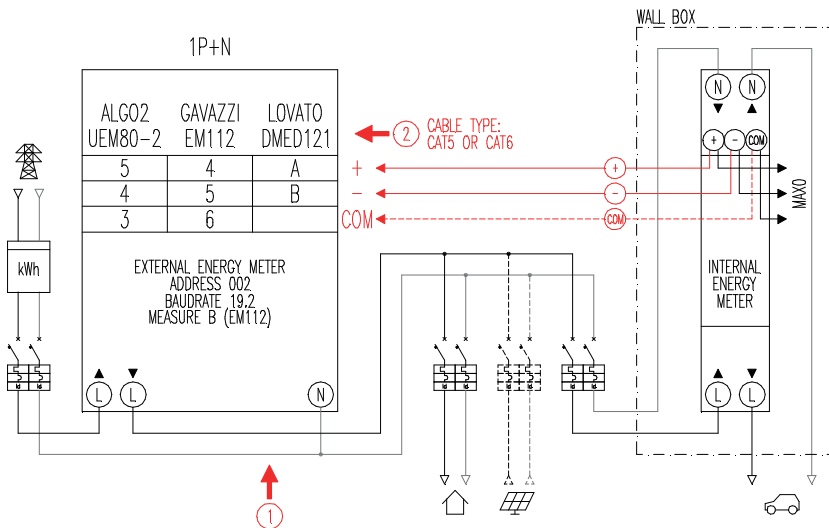

THREE-PHASE STATION

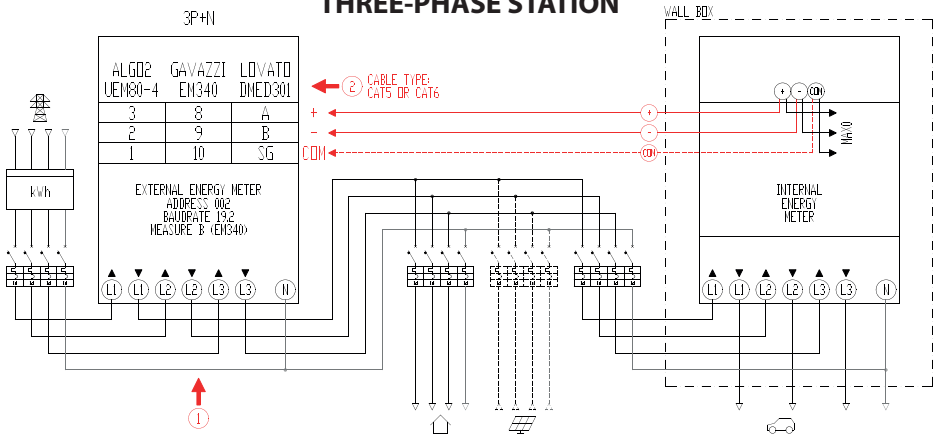

Notes:

1. Install the additional energy meter downstream of the energy meter and/or the main switch and upstream of any photovoltaic system.
2. Connect the additional energy meter to the internal energy meter using a shielded cable (e.g. CAT5-CAT6).
3. In the event of failed communication with the additional energy meter, the station prevents charging and "EMEX FAULT" appears on the display (see programming).
4. The maximum power supported by the additional energy meter is:
 - single phase 63A = 14,5kW; single phase 80A = 18,4kW; single phase 100A = 23kW
 - three phase 65A = 45kW; three phase 80A = 55,3kW

DISPLAY

During the charge, the charging time (hours/minutes/seconds) will appear on the display and the following will appear cyclically:

- Power output in kilowatt hours (**Etot**).
- Current absorbed by the vehicle in Amperes (only **L1** if single-phase, **L2+L3** for three-phase).
- Power absorbed by the vehicle in kilowatts (**Pist**).
- Total power absorbed from the mains in kilowatts (**Pest**).

PROGRAMMING

To access the programming menu, when SOCKET AVAILABLE (in free mode) or PRESENT CARD (in personal mode) appears on the display, hold in the stop button until POWER OUTPUT appears on the display.

Release the button and hold it in again until PASSWORD (default 000) appears on the display: short-press to increase the value, long-press to confirm the value.

After entering the password correctly, the following parameters will appear cyclically (short-press) on the display:

- **PMAX** (default 3kW): this is the value of maximum power that can be absorbed by the mains (usually corresponds to the value of the energy meter's contracted power).
- **Imin** (default 6.0A): this is the value of the minimum current at which your vehicle can charge (we recommend reading your vehicle's manual to determine the value).
- **Hpower** (default 1%): this is the hysteresis value of the power threshold at which the station pauses and resumes charging (for systems characterised by power surges, we recommend increasing the value to prevent frequent charging pauses and restarts).
- **Dset** (default 0.5kW): this is the value of power variation that does not affect the regulation system (for systems characterised by power surges, we recommend increasing the value to prevent frequent modulations of the vehicle charging current).
- **DMAX** (default 40%): the power surplus (with respect to the contractual power) beyond which the charge in progress is immediately suspended (this value should be reduced in the event of untimely tripping of the meter).
- **UNBALANCE** (default OFF): only for three-phase, it allows to unbalance the load to phase L1 in case of charge of single-phase vehicle
- **EMEX FAULT** (default ON): this enables or disables control of communication with the external energy meter (we recommend disabling control only in the event of an emergency since, without communication, the station does not modulate the power and charges constantly at the rated current set).
- **TIME RANGE** (default OFF): with PMAX between 3 and 4.5kW, enables the extension of the contractual power to a maximum of 6kW (including a 10% surplus) in consumption band 3 (this is valid exclusively in Italy, only for stations

with a local server in accordance with resolution 541/2020/R/EEL).

- **PASSWORD** (default 000): to change the default password.

The parameter displayed can be changed by long-pressing the stop button, short-press to increase the value, long-press to confirm the value.

If the button is not pressed for 10 seconds, the station returns to initial status.

MAINTENANCE

The charging station is essentially a distribution panel. The following operations should therefore be carried out by qualified personnel at regular intervals:

- Every six months: check structure and external components and check operation of safety switches.
- Every twelve months: check internal components and check tightness of terminals.

SUPPORT

In the event of operating issues, the first person to contact is your trusted installer.

The Scame customer service centre is available to respond to additional technical queries.

Visit our website: <https://e-mobility.scame.com/>



BUSINESS UNIT E-MOBILITY
VIA SPIAZZI, 45
24028 PONTE NOSSA (BG) ITALY
TEL. +39 035 705000
FAX +39 035 703122
e-mobility.scame.com
e-mobility@scame.com

ZP91114-GB-5