

Energy Meter

D13 15

User manual

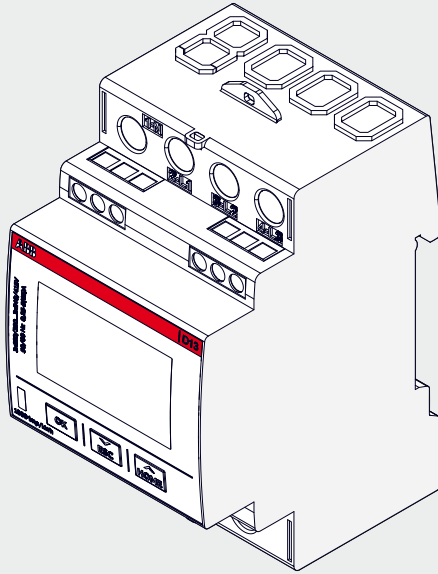

Table of Contents

1 General information.....	5
1.1 Use and storage of the manual.....	5
1.2 Copyright	5
1.3 Liability disclaimer	5
1.4 General safety warnings	5
1.5 Cyber Security Disclaimer.....	6
2 Technical characteristics	7
2.1 Product marking.....	7
2.2 Versions.....	9
2.3 Overall dimensions	9
2.4 Main functionalities.....	10
2.5 Technical data.....	11
2.6 Insulation map.....	12
3 Installation.....	13
3.1 Mounting the meter	13
3.2 Environmental considerations	14
3.3 Installing the meter	14
3.4 Wiring diagrams.....	16
3.5 Configuring the meter	20
4 First commissioning.....	21
4.1 Fast setup.....	21
4.2 Final confirmation	24
5 Access to device.....	25
5.1 Button explanation	25
5.2 Display structure.....	25
5.3 Menu.....	26
5.4 Icons description and status.....	27
5.5 Main menu.....	28
6 Configuration.....	30
6.1 Menu structure	30
6.2 Setting a value.....	31
6.3 Setting Password.....	33
6.4 Reset options	34
6.5 Setting Standby options	35
6.6 Setting Autoscroll options.....	36
6.7 Setting Currency/CO2.....	37

6.8 Setting Wires	37
6.9 Setting I-0	38
6.10 Setting Alarm.....	39
6.11 Setting Tariff	41
6.12 Setting Modbus communication	41
6.13 Setting M-bus communication.....	42
7 Technical meter functionalities	43
7.1 Energy Values	43
7.2 Instrumentation functions	43
7.3 Alarm.....	44
7.4 Inputs and Outputs	45
7.5 Logs.....	47
8 Measurement methods	49
8.1 Measuring Energy and power.....	49
8.2 Single phase metering.....	54
8.3 3-Phase 3-wire metering	55
8.4 3-Phase 4-wire metering	56
9 Service & Maintenance	57
9.1 Service	57
9.2 Event codes.....	57
9.3 Cleaning.....	58
10 Communication manual	59
10.1 QR Code.....	59

1 General information

1.1 Use and storage of the manual



Carefully read this manual and adhere to the indications described prior to using the device.

This manual contains all of the safety information, the technical aspects and the operations necessary to ensure the correct use of the device and maintain it in safe conditions.

1.2 Copyright

The copyright of this manual is the property of ABB S.p.A.

This manual contains texts, designs and illustrations of a technical nature which must not be disclosed or transmitted to third parties, even partially, without the written authorisation of ABB S.p.A.

1.3 Liability disclaimer

The information contained in this document is subject to change without notice and cannot be considered as an obligation by ABB S.p.A. ABB S.p.A. is not liable for any errors that may appear in this document. ABB S.p.A. is not liable under any circumstances for any direct, indirect, special, incidental or consequential damage of any kind that may arise from using this document. ABB S.p.A. is also not liable for incidental or consequential damage that may arise from using the software or hardware mentioned in this document.

1.4 General safety warnings



Non-adherence to the following points can lead to serious injury or death.

Use the suitable personal protection devices and adhere to the current regulations governing electrical safety.

- This device must be installed exclusively by qualified personnel who have read all of the information relative to the installation.
- Check that the voltage supply and measurement are compatible with the range permitted by the device.
- Ensure that all current and voltage supplies are disconnected prior to carrying out any controls, visual inspections and tests on the device.
- Always assume that all circuits are under voltage until they are completely disconnected, subjected to tests and labelled.
- Disconnect all of the power supply prior to working on the device.
- Always use a suitable voltage detection device to check that the supply is interrupted.
- Pay attention to any dangers and carefully check the work area ensuring that no instruments or foreign objects have been left inside the compartment in which the device is housed.
- The correct use of this device depends on a correct manipulation, installation and use.
- Failure to adhere to the basic installation information can lead to injuries as well as damage to the electric instruments or to any other product.
- NEVER connect an external fuse in by-pass.
- Disconnect all of the input and output wires before carrying out a dielectric rigidity test or an insulation test on an instrument in which the device is installed.
- The tests carried out at a high voltage can damage the device's electronic components.
- The device has to be installed inside a switchboard.
- Installation of D13 shall include a switch or circuit breaker for the connection of voltage measurement terminals. The switch or circuit breaker must be suitably located and easily reachable and must be marked as the disconnecting device for D13.
- Switch off circuit breaker or switch before connecting or disconnecting the voltage measurement terminals.

1.5 Cyber Security Disclaimer

D13 Meter is designed to be connected and to communicate information and data via a network interface, which should be connected to a secure network. It is your sole responsibility to provide and continuously ensure a secure connection between the product and your network or any other network (as the case may be) and to establish and maintain appropriate measures (such as but not limited to the installation of firewalls, application of authentication measures, encryption of data, installation of antivirus programs, etc.) to protect the D13 Meter product, the network, its system and interfaces against any kind of security breaches, unauthorized access, interference, intrusion, leakage and/or theft of data or information. ABB S.p.A. and its affiliates are not liable for damages and/or losses related to such security breaches, unauthorized access, interference, intrusion, leakage and/or theft of data or information.

Although ABB S.p.A. provides functionality testing on the products and updates that we release, you should institute your own testing program for any product updates or other major system updates (to include but not limited to code changes, configuration file changes, third party software updates or patches, hardware change out, etc.) to ensure that the security measures that you have implemented have not been compromised and system functionality in your environment is as expected.

2 Technical characteristics

2.1 Product marking

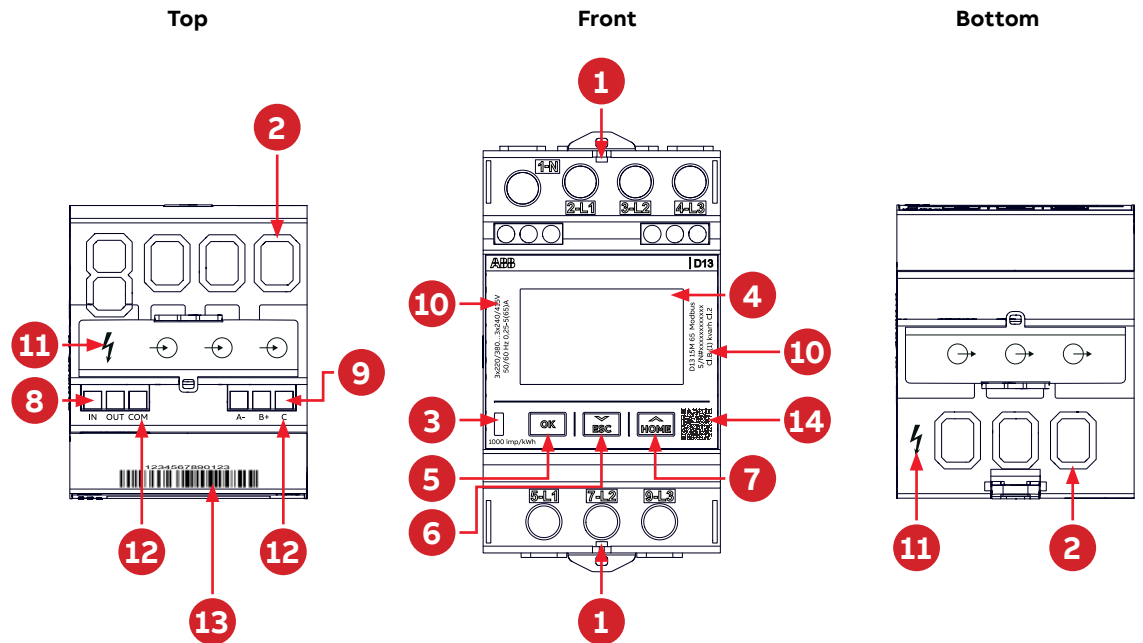

Parts description

1	Sealing points	Seal thread is used to seal the meter
2	Terminal block	Voltage and current terminals
3	LED	Flashes in proportion to the energy measured
4	Display	LCD for meter reading
5	OK pushbutton	Press to perform an action or to select a menu
6	DOWN/ESC pushbutton	Toggle down (short press) Esc from the menu (long press)
7	UP/HOME pushbutton	Toggle up (short press) Enter configuration mode (long press)
8	Terminal for input/output connection	
9	Terminal for communication connection	

Product label

10	Product information
11	Dangerous voltage
12	Terminals description
13	Serial number bar code
14	QR Code link to ABB Energy meter web page

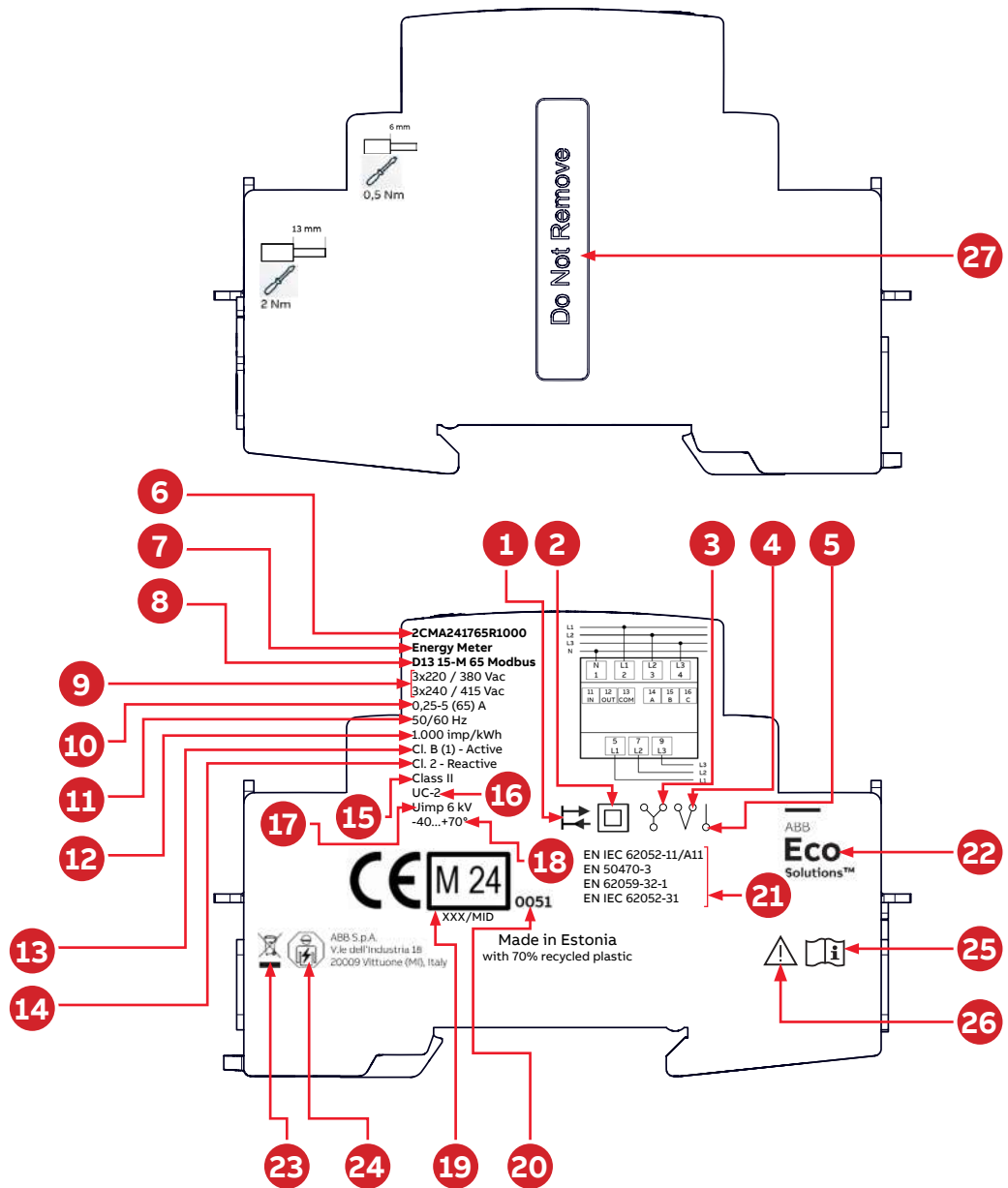

Product label

1	Import/Export of energy	17	Rated impulse voltage Uimp
2	Protective class II equipment	18	Operating temperature range
3	3-element metering	19	MID and year of verification
4	2-element metering	20	Notified body
5	1-element metering	21	Product standard
6	Product code	22	ECO Solution trademark
7	Product type	23	Used electrical and electronic devices must not be disposed with domestic waste
8	Type designation	24	Installation by person with electrotechnical expertise only
9	Nominal voltage	25	Refer to operating instructions
10	Current	26	Caution, refer to accompanying documents
11	Frequency	27	Sealing label (do not remove it)
12	LED pulse frequency		
13	Accuracy active energy		
14	Accuracy ractive energy		
15	Protective class		
16	Utilization category		

2.2 Versions

The D13 15 meters versions are listed in the below table:

Product name	Certification	Communication	I/O	Accuracy
D13 15 65	-	-		Cl. 1 - Active Cl. 2 - Reactive
D13 15-M 65	MID	-	1 Digital input 1 Digital output	
D13 15-M 65 Modbus	MID	Modbus RTU		Cl. B/1 - Active Cl. 2 - Reactive
D13 15-M 65 Mbus	MID	Mbus		
D13 P 15-M 65 Modbus	MID	Modbus RTU	-	Cl. B/1 - Active Cl. 2 - Reactive

2.3 Overall dimensions

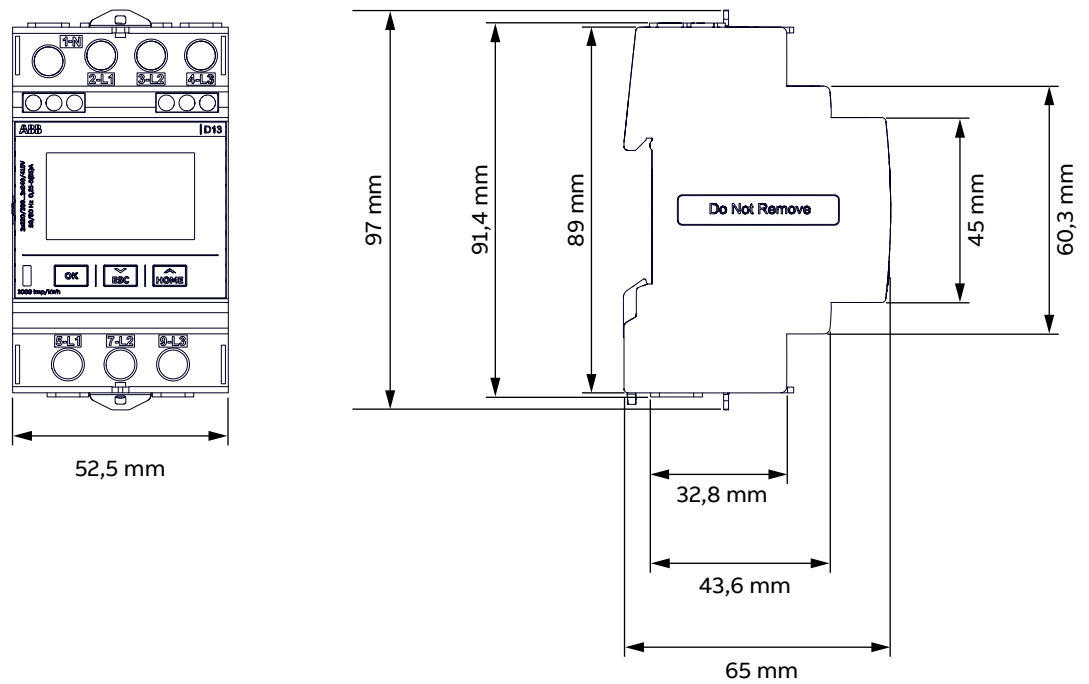

2.4 Main functionalities

Mechanical properties	
DIN modules	3
Overall dimensions	65 x 97 x 52,5 mm
Voltage/current inputs	
Direct connection	65A
Indirect connection via CT	No
Indirect connection via VT	No
Energy measurements	
Active energy	■
Reactive energy	■
Apparent energy	■
Equivalent Wh/CO2	■
Equivalent Wh/CUR	■
Import/Export	■
Instantaneous measurements	
Voltage	■
Current	■
Neutral current	Calculated
Frequency	■
Active power	■
Reactive power	■
Apparent power	■
Power quality measurements	
Power factor	■
Cos φ	■
Current quadrant	■
Function	
Tariffs with digital input	2
Tariffs via communication	4
Single alarms	25
Event logs (warnings, alarms and errors)	■
I/O	
Digital input	1
Digital output	1
Communication	
Pulse output	■
M-Bus (optional)	■
Modbus RTU (optional)	■
Password protection	
4 digits password	■

2.5 Technical data

Voltage/current inputs	
Nominal voltage	3 x 220/380 VAC 3 x 240/415 VAC
Voltage range	3 x 220-240 VAC +/- 20%
Power consumption voltage circuits	0.82 W maximum
Power consumption current circuits	0.006 W per phase
Base current I _b	5 A
Reference current I _{ref}	5 A
Transitional current I _{tr}	0.5 A
Nominal Current	5 A
Maximum current I _{max}	65 A
Minimum current I _{min}	0.25 A
Starting current I _{st}	20 mA
General data	
Frequency	50/60 Hz ± 5%
Accuracy Class index	B (Cl. 1) – Active Cl. 2 – Reactive
Meter constant	1.000 imp/kWh
Service type	3 Phases – 4 Wires 3 Phases – 3 Wires 1 Phase (Line 1) – 2 Wires 2 Phases – 3 Wires (Not MID)
Display of energy	7 digit LCD
Protective class	II
Overvoltage category	III
Pollution degree	2
Rated impulse voltage U _{imp}	6 kV
Utilization category (UC)	UC-2
Mechanical	
Material	Housing and terminal covers: made with at least 70% of recycle plastic Frontal Panel: UV resistant Polyester
Weight	250g
Environmental	
Operating temperature	-40°C to +70°C
Storage temperature	-40°C to +85°C - Data retention is guarantee for 10 years
Environmental conditions, operation	Indoor with extended operating temperature; dry locations
Altitude	2.000 m
Humidity	75% yearly average, 95% on 30 days/year
Resistance to fire and heat	Terminal 960°C, cover 650°C (IEC 60695-2-1) – UL V0
Resistance to water and dust	IP 20 on terminal block without protective enclosure and IP 51 in protective enclosure, according to IEC 60529
Mechanical environment	Class M2 in accordance with the Measuring Instrument Directive (MID), (2014/32/EU)
Electromagnetic environment	Class E2 in accordance with the Measuring Instrument Directive (MID), (2014/32/EU)

Digital Output	
Current	2...60mA
Voltage	5...40 VDC (+/-10%)
Max ON state drop Voltage	1,5V
Pulse output frequency	Prog. 1–999999 imp/MWh, 1–999999 imp/kWh, 1–999999 imp/Wh
Pulse length	10–990 ms
Insulation	SELV
Digital Input	
Max Voltage (absolute rating)	44 VDC
Off state Voltage	0...5 VDC (+/-10%)
ON state Voltage	10...40 VDC (+/-10%)
Min. pulse length and pulse pause	30 ms
Insulation	SELV
Communication	
M-Bus	EN 13757-2, EN 13757-3
Modbus	Modbus Application Protocol Specification V1.1b
Insulation	SELV
Pulse indicator (LED)*	
Pulse Frequency	1000 imp/kWh
Pulse length	40 ms
*The LED pulses control has time uncertainty (jitter) of 1 ms. In case of minimum measurements time of 10 seconds the measurements uncertainty is (1 ms / 10s) * 100 = 0.01% that is 1/100th of our rated accuracy of 1%. The maximum pulse frequency that we have is 500Hz, which is lower than the maximum of 2.5 kHz.	
EMC compatibility	
Impulse voltage test	6 kV 1.2/50µs (IEC 60060-1)
Surge voltage test	4 kV 1.2/50µs (IEC 61000-4-5)
Fast transient burst test	4 kV (IEC 61000-4-4)
Immunity to electromagnetic HF-fields	80 MHz–2 GHz at 10 V/m (IEC 61000-4-3)
Immunity to conducted disturbance	150kHz–80MHz, (IEC 61000-4-6)
Immunity to electromagnetic disturbances	2–150 kHz for kWh-meters
Radio frequency emission	EN 55022, class B (CISPR22)
Electrostatic discharge	15 kV (IEC 61000-4-2)
Standards	
	EN 50470-3:2022 (Only for MID meters) EN IEC 62052-11:2021/A11:2022 IEC 62052-31:2015-09 EN 62052-31:2016-06 EN 62052-31:2018:04 EN IEC 62053-21/A11:2021 EN IEC 62053-23/A11:2021 EN IEC 62053-23:2022:02 EN 62059-32-1:2012 CISPR 32:2015 Class B Welmec Guide 11.1 Welmec Guide 7.2

2.6 Insulation map

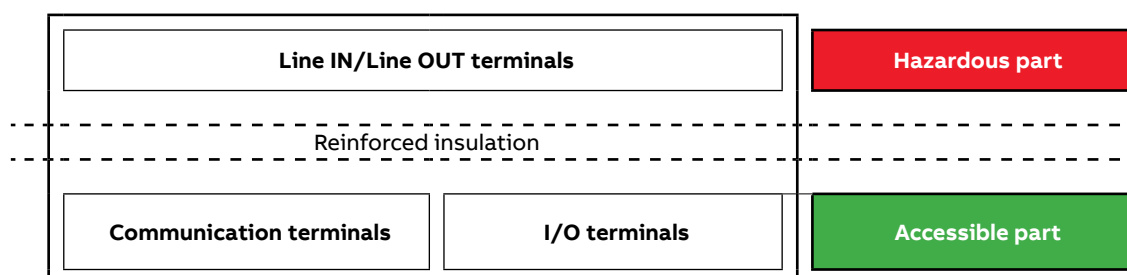

3 Installation

This chapter describes how to mount the D13 15-65 meters and how to connect them to an electricity network. The chapter also contains information about how to perform a basic configuration of the meter and how to connect I/O and communication options.



Generally, national regulations are in place concerning electrical installations. These regulations, among others, specify the type and size of the connection cables to be used.

3.1 Mounting the meter

This section describes different ways to mount the D13 15 meters. For some methods of mounting additional accessories are needed. For further information about accessories, refer to the Main Catalog (9AKK107492A3149).

DIN-rail mounted

The D13 15 meters are intended to be mounted on a DIN-rail (DIN 50022). If this method of mounting is used no extra accessories are needed and the meter is fastened by snapping the DIN-rail lock onto the rail. The following picture shows a DIN-rail.

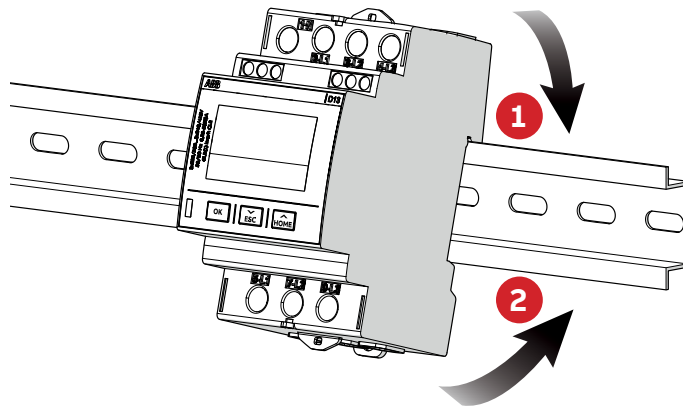

Wall mounted

The recommended way to mount the meter on a wall is to mount a separate DIN-rail on the wall and then mount the meter on the rail.

3.2 Environmental considerations

Ingress protection

The product is for indoor use only. To comply with the protection requirements the product must be mounted in a fireproof meter cabinet with protection class IP 51 or better, according to IEC 60259.

Mechanical environment

In accordance with the Measuring Directive (2014/32/EU), the product complies with M2, which means that it can be operated in "...locations with significant or high levels of vibration and shock, e.g. transmitted from machines and passing vehicles in the vicinity or adjacent to heavy machines, conveyor belts, etc."

Electromagnetic environment

In accordance with the Measuring Directive (2014/32/EU), the product complies with E2, which means that it can be operated " ...in locations with electromagnetic disturbances corresponding to those likely to be found in other industrial buildings."

Climatic environment

In order to work properly the product should not be operated outside the specified temperature range of -40°C - +70°C. In order to work properly the product should not be exposed to humidity exceeding the specified 75% yearly average, 95% on 30 days/year. The product is made for indoor use only.

3.3 Installing the meter

Warnings



Warning - Electrical equipment should only be installed, accessed, serviced and maintained by qualified electrical personnel. Working with high voltage is potentially lethal. Persons subjected to high voltage may suffer cardiac arrest, burn injuries, or other severe injuries. To avoid such injuries, make sure to disconnect the power supply before you start the installation.



Warning - For safety reasons it is recommended that the equipment is installed in a way that makes it impossible to reach or touch the terminal blocks by accident. The best way to make a safe installation is to install the unit in an enclosure. Further, access to the equipment should be limited through use of lock and key, controlled by qualified electrical personnel.



Warning - The meters must always be protected by fuses on the incoming side or by an adequate MCB (see "[Circuit protection](#)" for details).

Cable type

Cable type connected to the voltage/current terminals shall be solid or stranded copper cable. When using stranded cable end ferrules can be used.

Install the meter

Follow the steps in the table below to install and verify the installation of the meter:

Step	Action
1	Switch off the mains power.
2	Place the meter on the DIN-rail and make sure it snaps onto it.
3	Strip the cable insulation to the length that is indicated on the meter.
4	Connect the cables according to the wiring diagram that is printed on the meter and tighten the screws following the table “Communication” .
5	Install the circuit protection (See “Circuit protection”).
6	If inputs/outputs are used, connect the cables according to the wiring diagram that is printed on the meter and tighten the screws following the table “Communication” . Then connect to an external power supply following the rating voltage values (max 40Vdc).
7	If communication is used, connect the cables according to the wiring diagram that is printed on the meter and tighten the screws following the table “Communication” .

Verify installation

Follow the steps in the table below to verify the installation of the meter:

Step	Action
8	Check that the meter is connected to the specified voltage and that voltage phase connections and the neutral (if used) are connected to the correct terminals.
10	Switch on the power. If a warning symbol is displayed, refer to the error codes in “9.2 Event codes” .
11	Under the menu item “Instantaneous Values” on the meter, check that the voltages, currents, power and power factors are reasonable and that the power direction is what to be expected (the total power should be positive for a load that consumes energy). When doing the check the meter should be connected to the intended load, preferably a load with a current above zero on all phases to make the check as complete as possible.

Circuit protection

Use the information in this table to select the correct fuse for the circuit protection:

Meter type	Max circuit protection
Direct connected	65 A MCB, C characteristic or 65 A fuse type gL-gG



Generally, there exist national regulations covering the protection of the electrical installation. These regulations, among others, specify the kind, rating and characteristics of external protection devices, for example circuit breakers and fuses. Their selection depends on the location where the metering equipment is installed.

The installer is responsible for coordinating the rating and the characteristics of the supply side overcurrent and overload protection devices with the maximum current rating and, in the case of direct connected meters, with the UC rating of the metering equipment.

3.4 Wiring diagrams

This section describes how to connect the meter to an electricity network. The terminal numbers in the wiring diagrams listed below correspond to the marking on the terminal block of the meter.



In a case of MID meter, D13 will enter in MidLock once an energy consumption of 1kWh has been reached. When MidLock is reached, wiring settings can no longer be modified in accordance with the European MID directive.

• 3-phase 4-wire connection (MID)

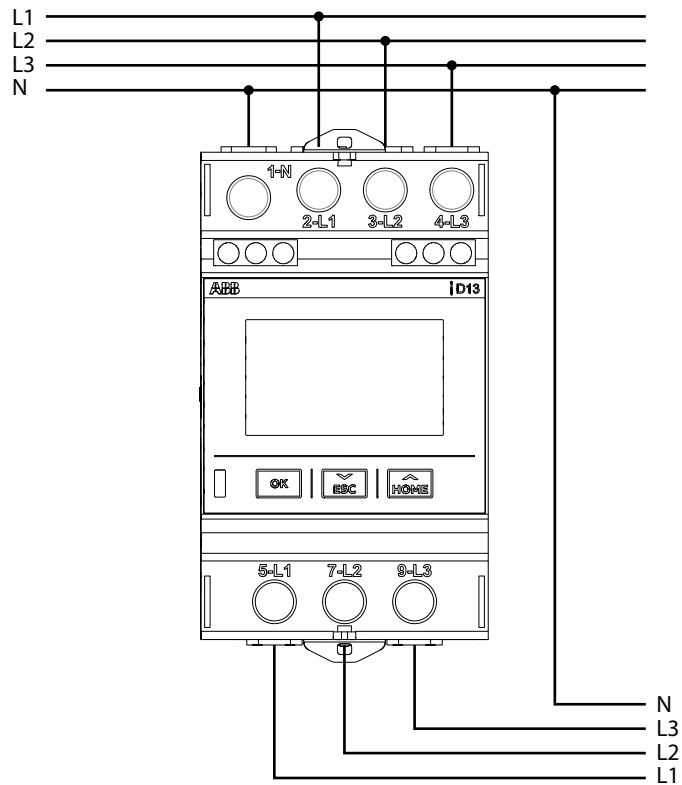

• 3-phase 3-wire connection (MID)

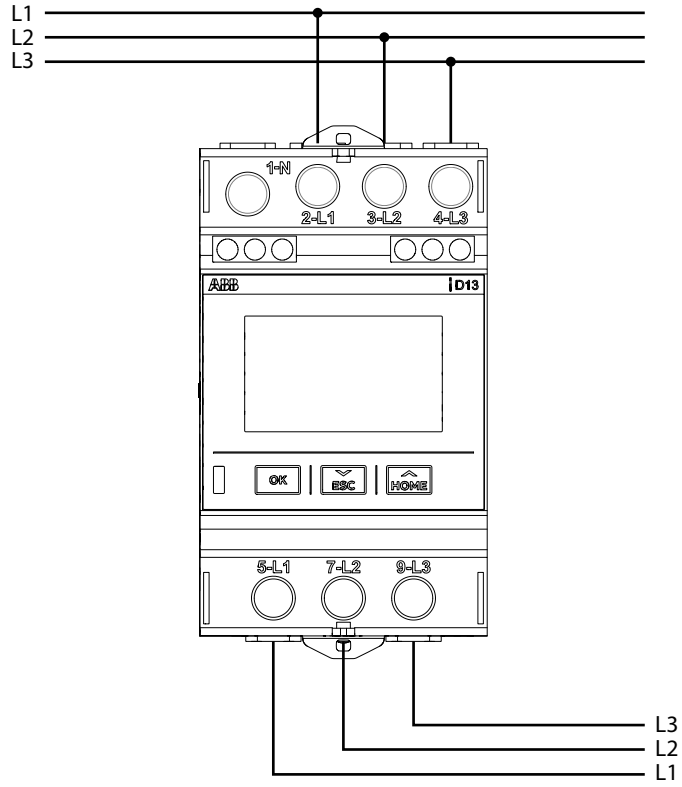

• 2-phase 3-wire connection (No MID configuration)

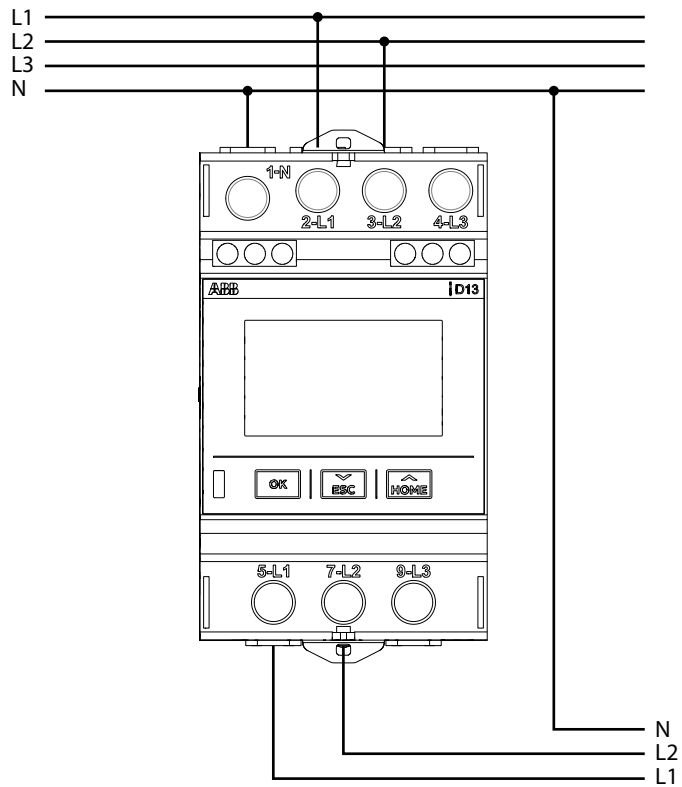

This configuration does not meet the MID certification (2014/32/EU directive).

• 1-phase 2-wire connection (MID)

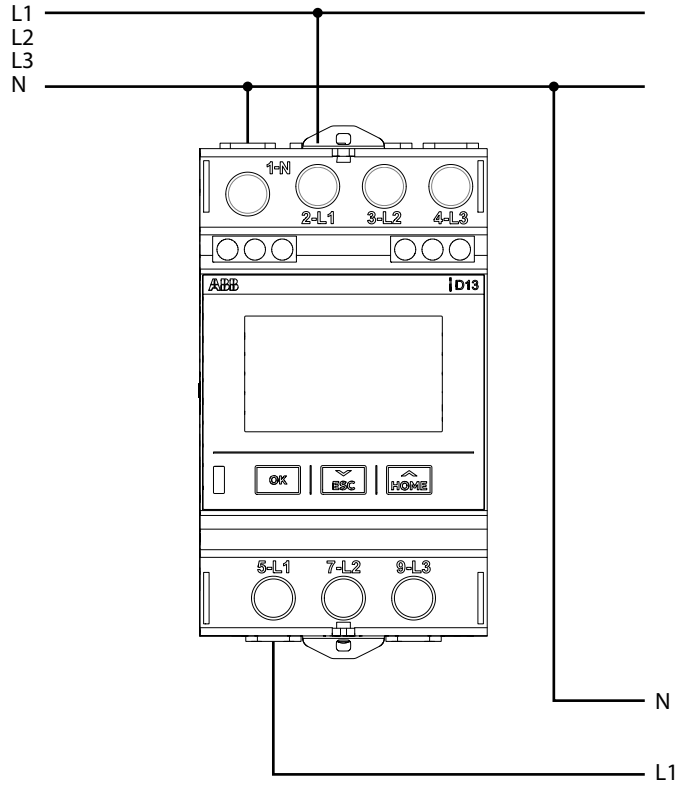

In order to meet the MID directive (2014/32/EU) only Line 1 shall be used.

Input/Output

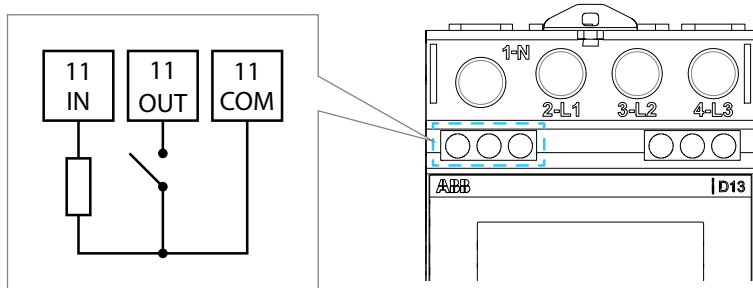

• Input connection

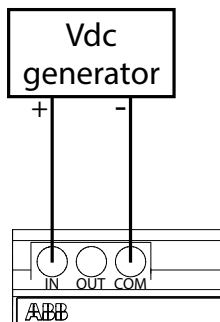

• Output connection

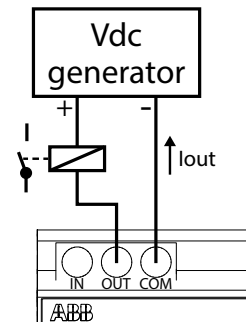
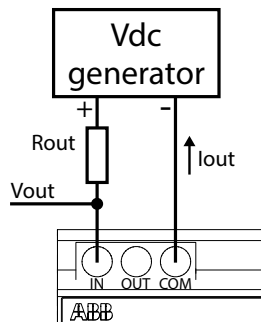

Communication

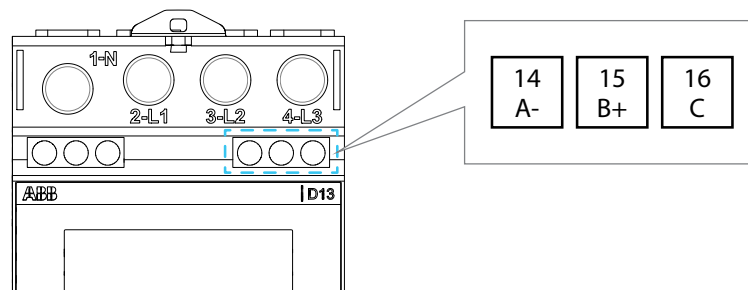

RS485 - Modbus RTU version	MBUS version
A = Data -	A = MBUS A
B = Data +	B = MBUS B
C = Common	C = Not used

Terminal Connectors

Line terminals	
Min. wire cross section	1 mm ²
Max. wire cross section	25 mm ²
Thread	M5
Screw head	PZ2
Tightening torque	2 Nm
Wire stripping length	13 mm
Neutral terminals	
Min. wire cross section	2 x 1 mm ²
Max. wire cross section	2 x 25 mm ²
Thread	M9
Screw head	PZ2
Tightening torque	2 Nm
Wire stripping length	13 mm
Communications and I/O terminals	
Poles	3
Pitch	5/5,08 mm
Min. wire cross section	0,2 mm ² (AWG 24)
Max. wire cross section	2,5 mm ² (AWG 12)
Thread	M2
Screw head	PZ1
Tightening torque	0,5 Nm
Wire stripping length	6 mm



The use of cables with a section smaller than 25mm² falls under the responsibility of the installer.

3.5 Configuring the meter

Default settings

For information about how to change the default settings of the meter, refer to [“6 Configuration”](#).

The following table lists the default meter settings:

Parameter	Direct connected meters
Numbers of wires	3P4W: 3 phase 4 wires
Pulse frequency	1.000 impulses / kWh (kvarh)
Pulse length	10 ms
Communication M-Bus	Address: 1
	Baud rate: 2400
	Access level: Open
Communication Modbus	Address: 1
	Baud rate: 19200
	Parity: Even

4 First commissioning

At first power up of D13 15 energy meter, a wizard procedure will guide the user in the first commissioning steps.

4.1 Fast setup

During fast setup, the user has to take one of the following choices:

- a) **NOT** perform the Fast Setup: In this case, the meter takes the following default parameters:
 - **Wire:** 3P4W;
 - **Communication:**
 - In a case of Modbus meter → Address: 1; Baud: 19200; Parity: Even.
 - In a case of Mbus meter → Address: 1; Baud: 2400; Access: Open.
 - In a case of Pulse → DO: Pulse.
- b) Perform **LATER** the Fast Setup: every time the user goes into setting menu, meter will ask to run the fast setting until 1kWh is reached.
- c) **Perform the Fast Setup:** in this case, the user can configure wiring, communication and password.

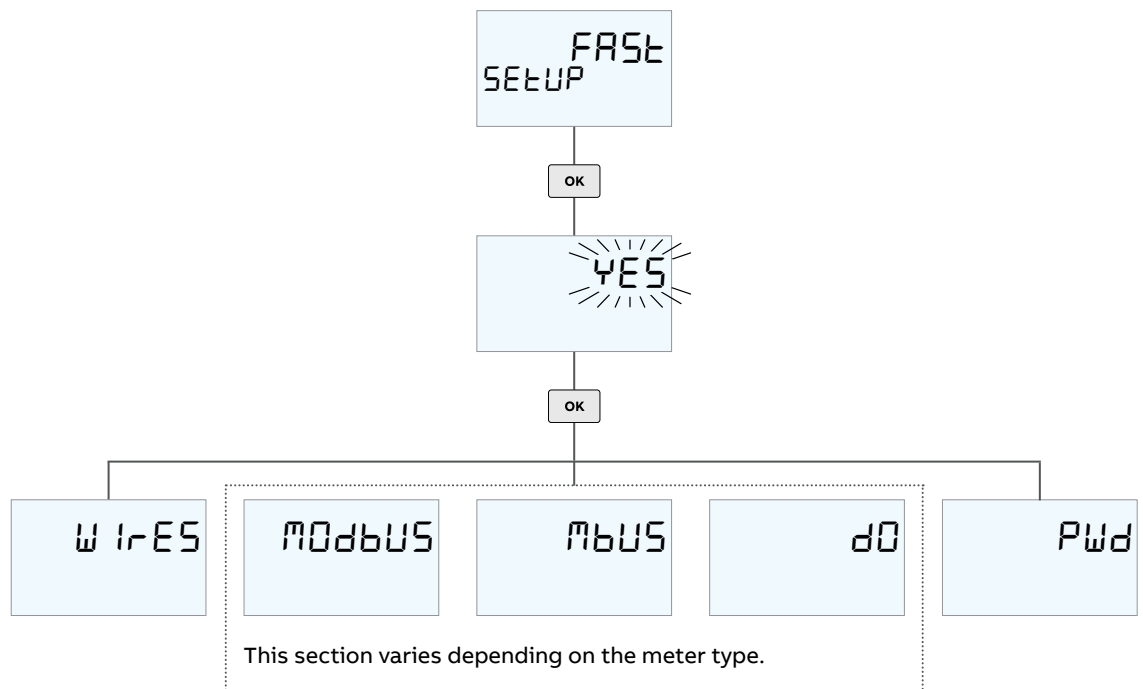

Fast setup - Wires configuration

In wires menu user can declare which is the meter’s wiring scheme applied.



D13 will enter in MidLock once an energy consumption of 1kWh has been reached. When MidLock is reached, wiring settings can no longer be modified in accordance with the European MID directive.

To perform the wires setting, please follow the following step:

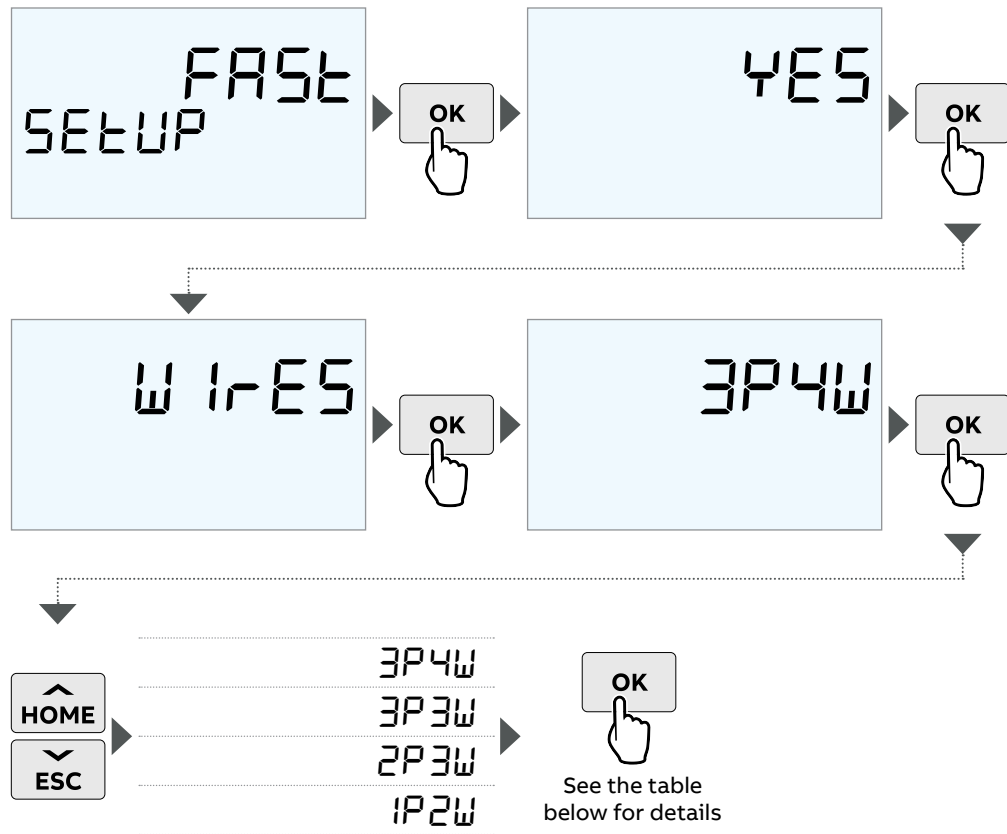

Type of wiring	Number of wires
3 phase	4 wires
	3 wires
2 phase	3 wires
1 phase	2 wires

If the wires scheme is not set, a default parameter is considered: **3P4W**.

Fast setup - Communication settings

Second step of fast setup is related to communication parameters that vary depending on the meter's type:

- In a case of **Modbus** meter, the following steps have to be performed (“6.12 Setting Modbus communication”):

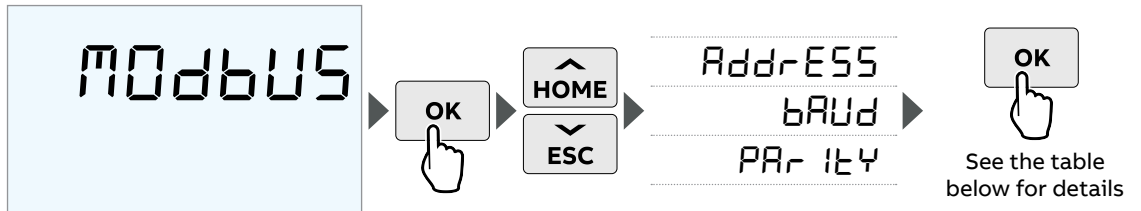

Modbus menu	
Address	1-247
Baud	115200
	57600
	38400
	19200
	9600
	4800
Parity	2400
	1200
	Even
	Odd
	None

- In a case of **Mbus** meter, the following steps have to be performed (see “6.13 Setting M-bus communication”):

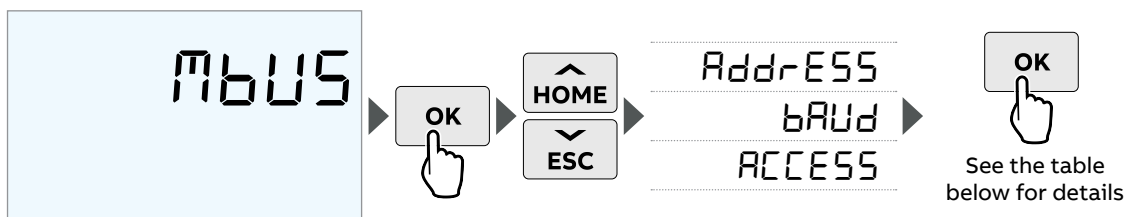

Mbus menu	
Address	1-257
Baud	9600
	4800
	2400
	1200
	600
	300
Parity	Open
	Pwd
	Close

- In a case of meter without Modbus or Mbus, the following steps have to be performed:

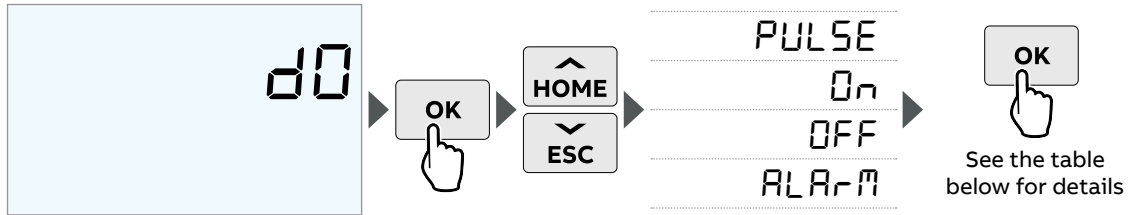

DO menu	
Pulse	Quant tot IMP kW h (Total Import Active energy) Quant tot EXP kW h (Total Export Active energy) Quant tot IMP k VARh (Total Import Reactive energy) Quant tot EXP k VARh (Total Export Reactive energy)
On	
Off	
Alarm	Select and set the parameter (quantity) associated with the channel (see “6.10 Setting Alarm”).

Fast setup - Password configuration

In order to protect settings of your meter, a 4 digits password can be set (see “6.3 Setting Password”):

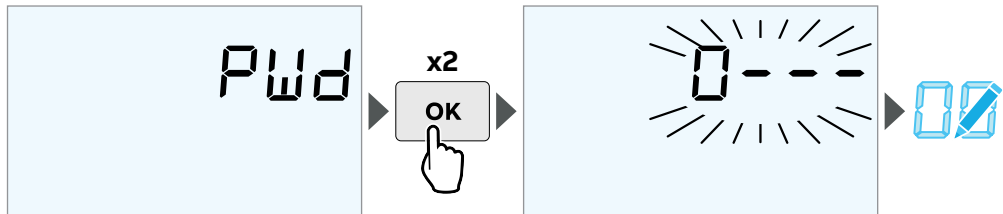

4.2 Final confirmation

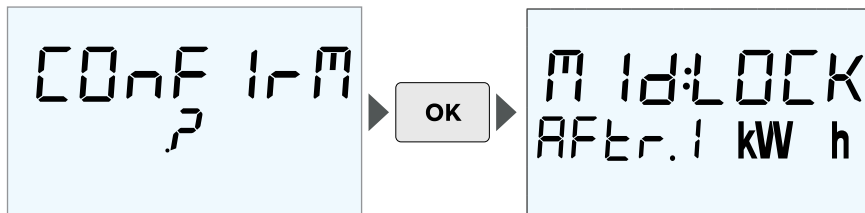

Once all fast setup settings are performed a confirmation is needed:



In a case of MID meter, the Midlock alert is shown to remind that wires scheme cannot be modified anymore when 1kWh is reached according to MID Directive.

5 Access to device

5.1 Button explanation

Buttons	Functions	
	Press	Hold
	Set/Confirm the value selected	
	Scroll up/Increase a digit	Return to the main menu
	Scroll down/Decrease a digit	Return to the previous menu



5.2 Display structure

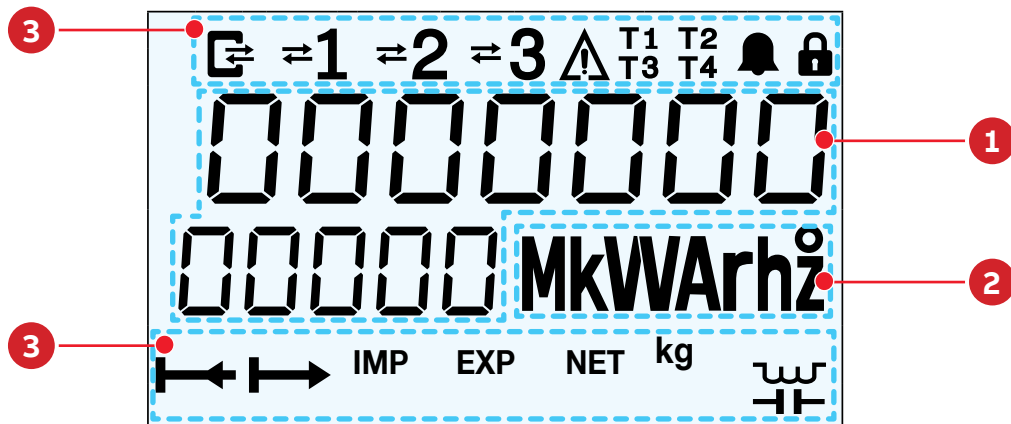







The display structure is divided into 3 main areas, as shown in the figure below:





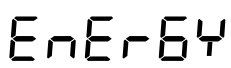

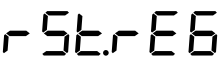
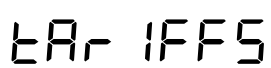
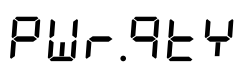

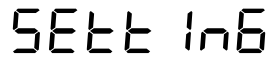

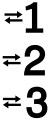

N	Area	Description
1	Measurements/Title	Specific measured value; Title of the content displayed on each screen, including MENU, READ and SET...
2	Magnitude/Unit	Magnitude includes K and M; Unit includes V, A, W and WH...
3	Icons	Indicating various types of state; For further details, see “5.4 Icons description and status”

5.3 Menu

Pushing  or  the screen shows the following pages:

Icon	Indication
	Home – Active import
	Home – Active export
	Home – Reactive import
	Home – Reactive export
	Energy
	Instantaneous Values
	Reset Register
	Tariffs
	Power Quality
	Input/Output
	Logs
	Settings

5.4 Icons description and status

Icon	Description	Status
	Communication is in progress. The meter is either sending “→” or receiving “←” information	When communication is in progress the icon switch on
	Arrows indicate direction of current per phase. A digit without arrow indicates that the current is below the starting current on that phase	Arrow left = export Arrow right = import
	Notification of error	During the phase where 1kWh is not yet reached: it blinks continuously
	Notification of warning	
	Notification of alarm	During alarm: the bell is flashing; If the alarm happened: the bell is switched on and fix
	Active tariff	Display shows the active tariff
	Configuration mode is protected with a PIN	If you put wrong pin 3 times, the lock icon starts to blink for 30second
NET	Net value (together with unit on page)	
EXP	Export (together with unit on page)	
IMP	Import (together with unit on page)	
kg	Kg of CO2 calculated	
	Total system exporting energy (connected to phases/lines)	When icon turns on, it means the Meter is measuring the total system exporting energy
	Total system importing energy (connected to phases/lines)	When icon turns on, it means the Meter is measuring the total system importing energy
	Inductive load in the system (independent of anything else)	
	Capacitive load in the system (independent of anything else)	

5.5 Main menu

All data reading may be available in the display depending on wiring scheme (see “7.2 Instrumentation functions”).

EnErGy	InStAnt
Active Energy Import Tot	Active Power Tot
Active Energy Import L1	Active Power L1
Active Energy Import L2	Active Power L2
Active Energy Import L3	Active Power L3
Active Energy Export Tot	Reactive Power Tot
Active Energy Export L1	Reactive Power L1
Active Energy Export L2	Reactive Power L2
Active Energy Export L3	Reactive Power L3
Active Energy Net Tot	Apparent Power Tot
Active Energy Net L1	Apparent Power L1
Active Energy Net L2	Apparent Power L2
Active Energy Net L3	Apparent Power L3
Reactive Energy Import Tot	L-N Voltage L1-N
Reactive Energy Import L1	L-N Voltage L2-N
Reactive Energy Import L2	L-N Voltage L3-N
Reactive Energy Import L3	L-L Voltage L1-L2
Reactive Energy Export Tot	L-L Voltage L2-L3
Reactive Energy Export L1	L-L Voltage L3-L1
Reactive Energy Export L2	Current L1
Reactive Energy Export L3	Current L2
Reactive Energy Net Tot	Current L3
Reactive Energy Net L1	Neutral Current
Reactive Energy Net L2	Frequency
Reactive Energy Net L3	
Apparent Energy Tot	
Apparent Energy L1	rStREg
Apparent Energy L2	Active Energy Import
Apparent Energy L3	Active Energy Export
Equivalent Wh/CO2	Reactive Energy Import
Equivalent Wh/CUR	Reactive Energy Export

EA-1FF

Active Energy Import T1

Active Energy Import T2

Active Energy Import T3

Active Energy Import T4

Active Energy Export T1

Active Energy Export T2

Active Energy Export T3

Active Energy Export T4

Reactive Energy Import T1

Reactive Energy Import T2

Reactive Energy Import T3

Reactive Energy Import T4

Reactive Energy Export T1

Reactive Energy Export T2

Reactive Energy Export T3

Reactive Energy Export T4

PW-9EY

Power Factor Tot

Power Factor L1

Power Factor L2

Power Factor L3

Cosphi Tot

Cosphi L1

Cosphi L2

Cosphi L3

Current Quadrant Tot

Current Quadrant L1

Current Quadrant L2

Current Quadrant L3

I-0

Output Type

Output Status

Input Type

Pulse Counter

LOGS

All

Alarms

Warnings

Errors

Audit

SEt INg

Fast Setup

Modify

Read

6 Configuration

This chapter gives an overview of the meter settings and configuration.

6.1 Menu structure

Fast Setup (Only the first time)	
Set/Modify Password	
Reset	Factory
	Global
	Resettable registers (Rst.Rg on display)
	Log
Bright (%)	
Standby	Delay (second)
	Bright (%)
Autoscroll	On; Off; Delay
Equivalent Currency/CO ₂	
Wires	
I-O	Pulse Output (Pul.Out. on display)
	Communication Output
	Alarm Output
	Pulse Input
	Tariff Input
Alarm	1-25
Tariff	Communication
	Input
Modbus (*)	Address
	Baudrate
	Parity
M-bus (*)	Address
	Baudrate
	Access level

(*) The communication setting varies depending on the meter type.

6.2 Setting a value

Buttons	Functions	
	Press	Hold
	Set/Confirm the value selected	
	Scroll up/Increase a digit	Return to the main menu
	Scroll down/Decrease a digit	Return to the previous menu

Setting a number procedure

Link	Description
	The menu requires the entry of numerical characters (0-9). Perform the steps as follows:

Example: insert "3582"

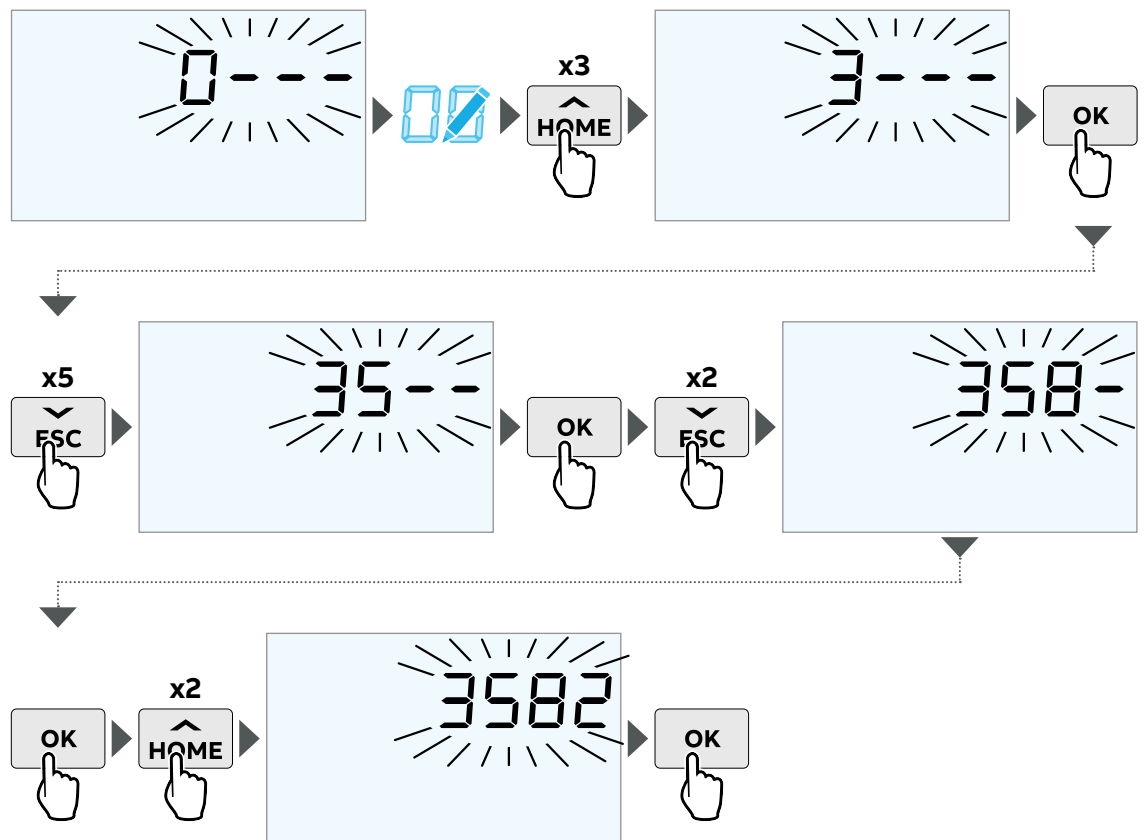



The option/digit that is active for setting is flashing. When the flashing on the last option has stopped, the setting has been performed.

Example: flashing option

Example: flashing digit

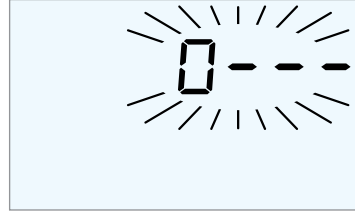
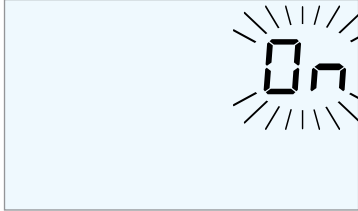

After configuring a setting, a confirmation screen always appears. Press to make the change definitive.

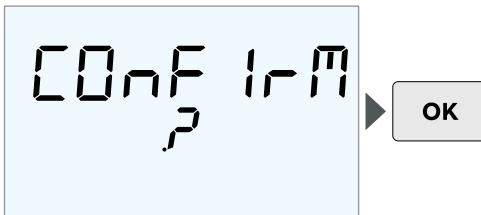

In the setting menu, a read/modify option are available. After a "Modify" selection, insert the password if required (see "6.3 Setting Password").

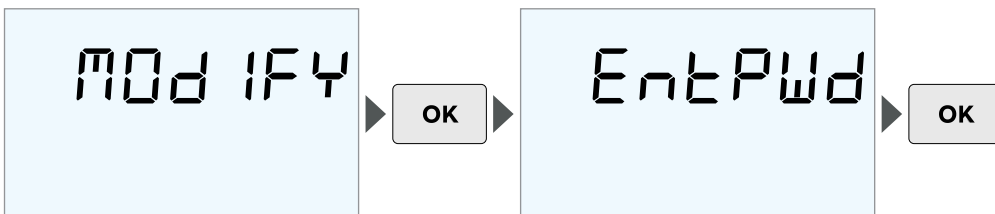

6.3 Setting Password

• Activate/deactivate password

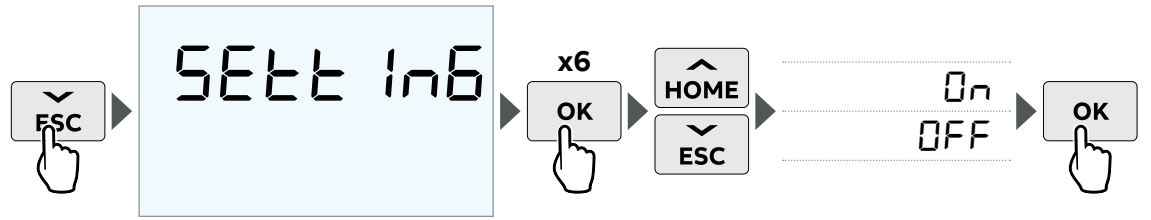

• Modify password

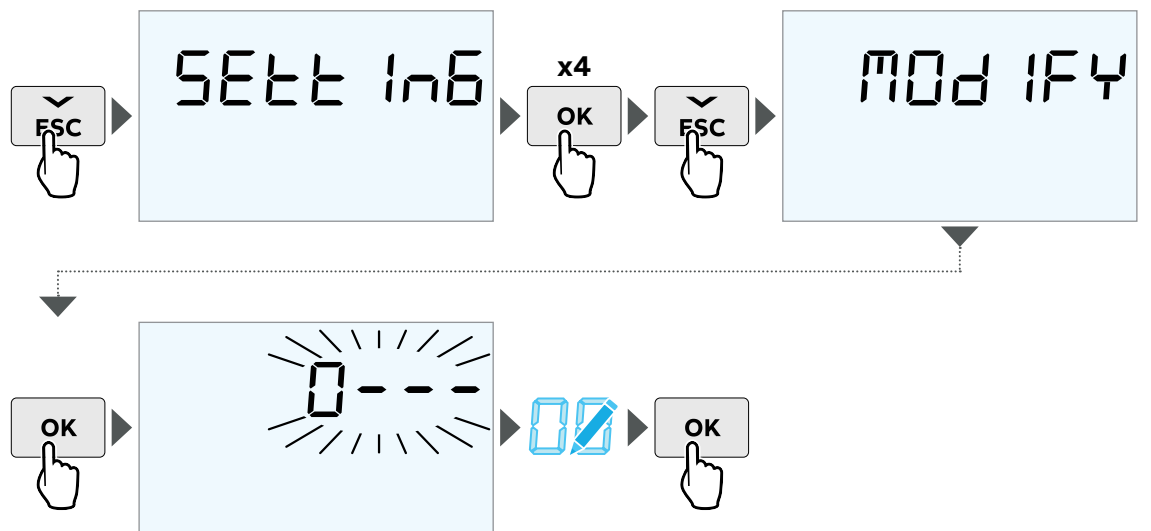

Insert the new password (previously the device ask the old password if it was configured).

6.4 Reset options

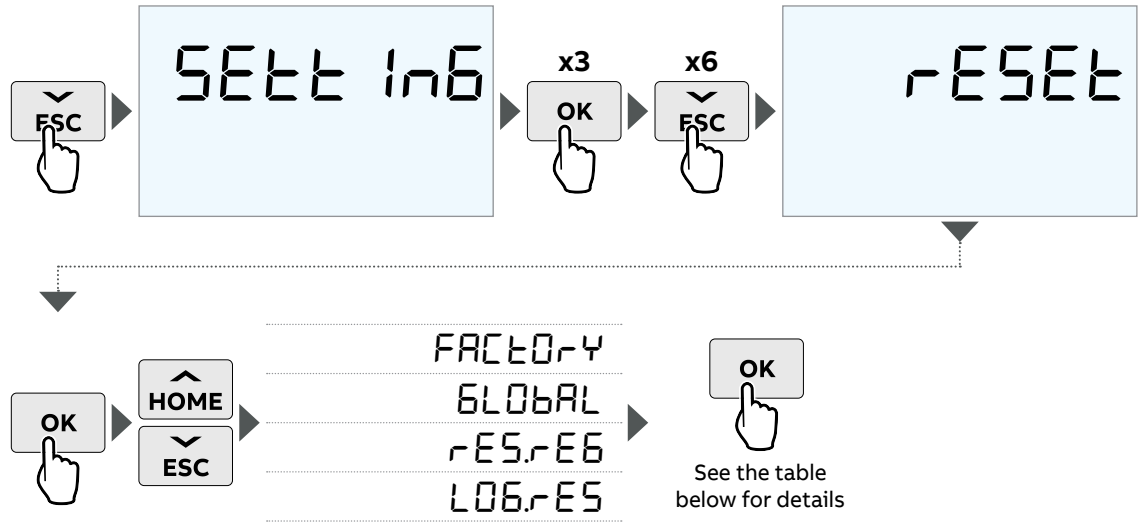

Reset options	
Factory reset	Restore the device to the factory state, except for the audit log, and wiring scheme in a case of MID meter
Global reset	Complete reset of the device except for the settings and the audit log
Reset registers	Selectable registers: Tot IMP Active energy Tot EXP Active energy Tot IMP reactive energy Tot EXP reactive energy
Log reset	

6.5 Setting Standby options

The meter allows to set the time interval necessary for the device to enter standby and the brightness maintained by the device once it enters this phase.

To change these parameters, perform the following steps:

• Set standby delay

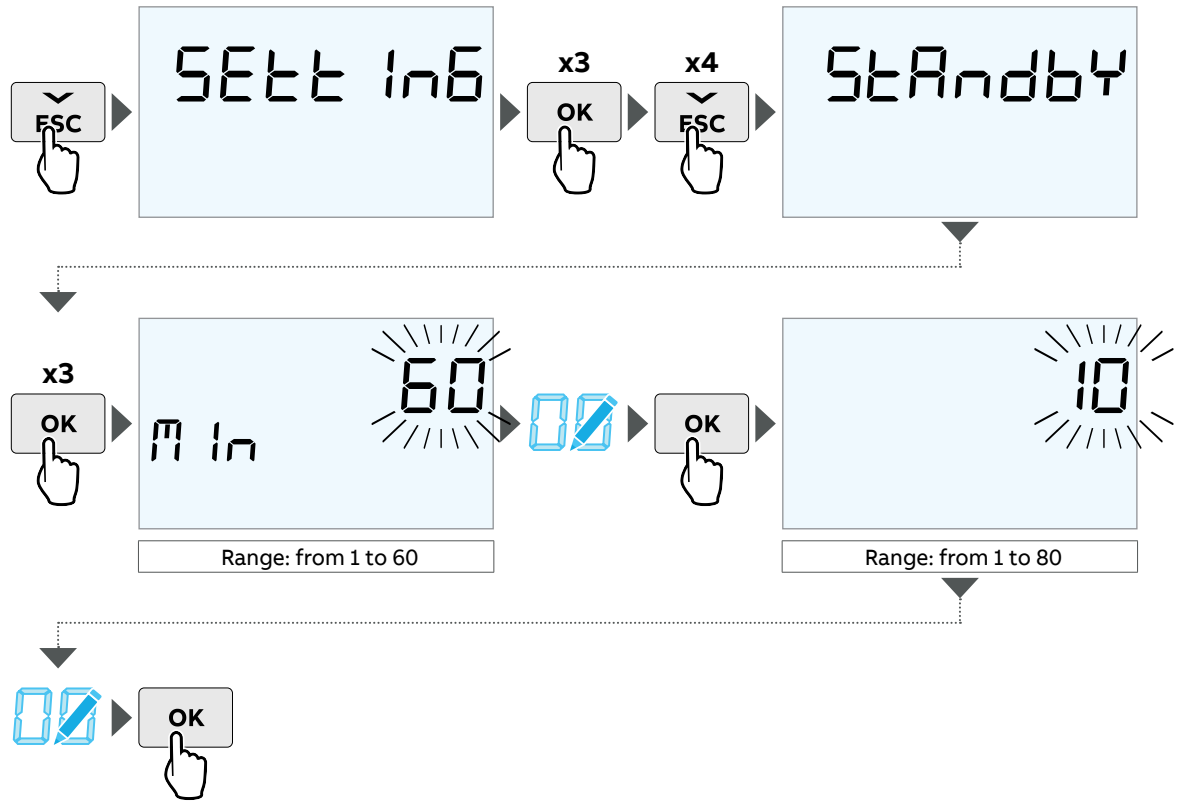

• Set standby device brightness

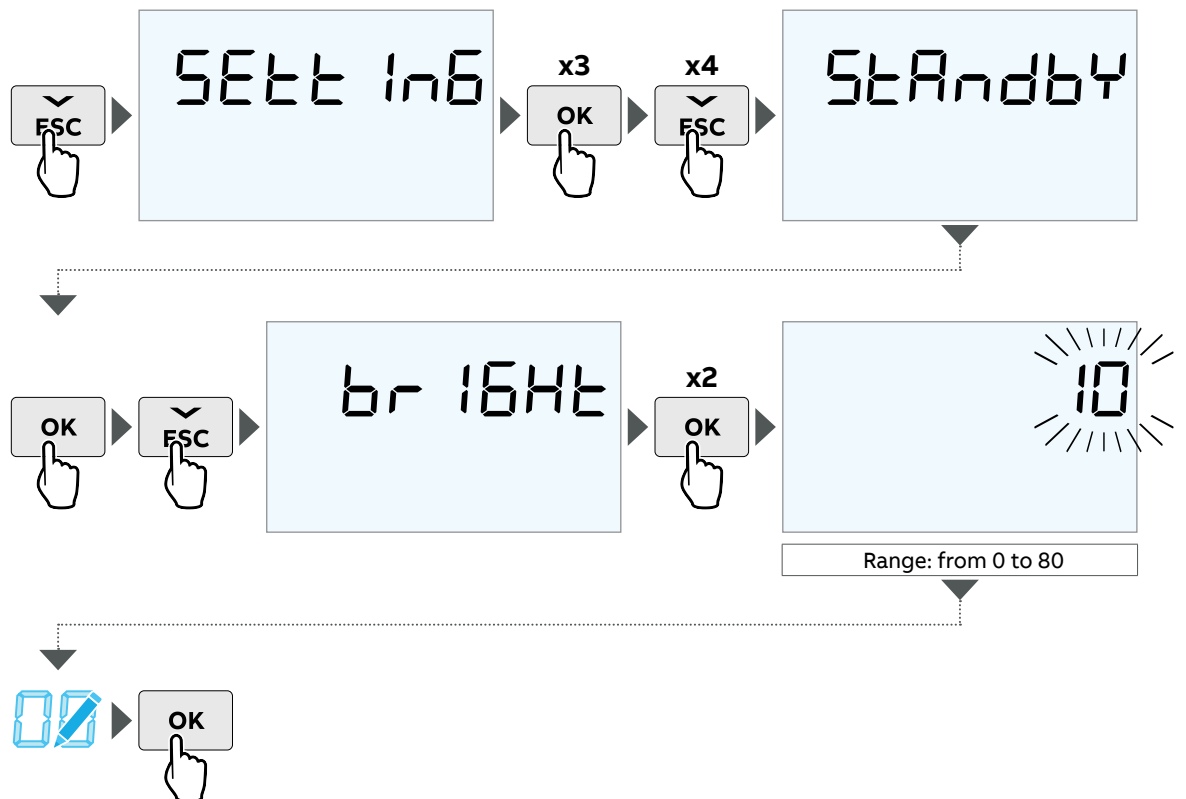

6.6 Setting Autoscroll options

The device is equipped with an Autoscroll feature that can be activated or deactivated. It is also possible to set the time interval necessary for the automatic scroll to take place. To set this options, perform the following steps:

• Activate/deactivate autoscroll

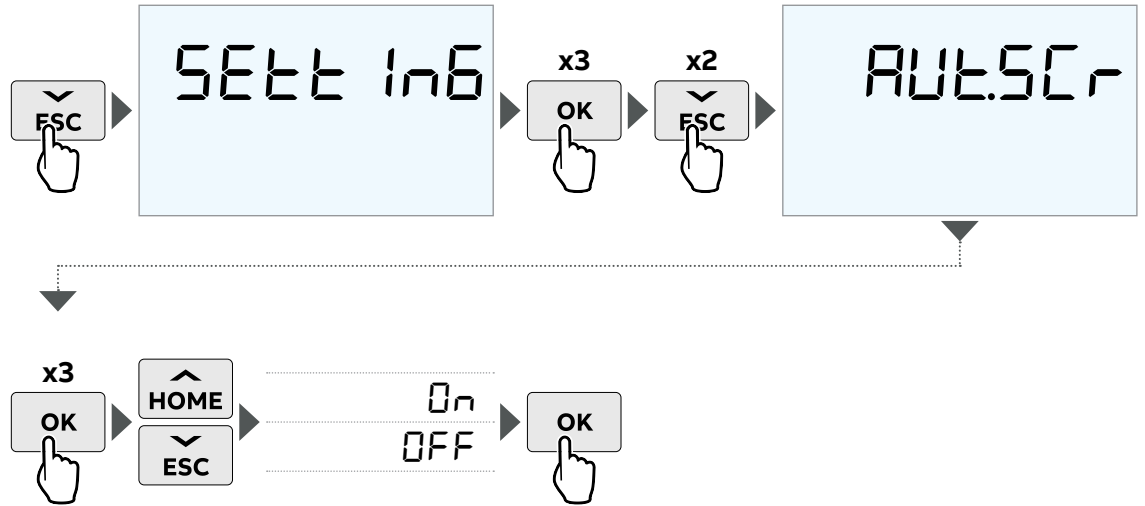

• Set a delay of autoscroll

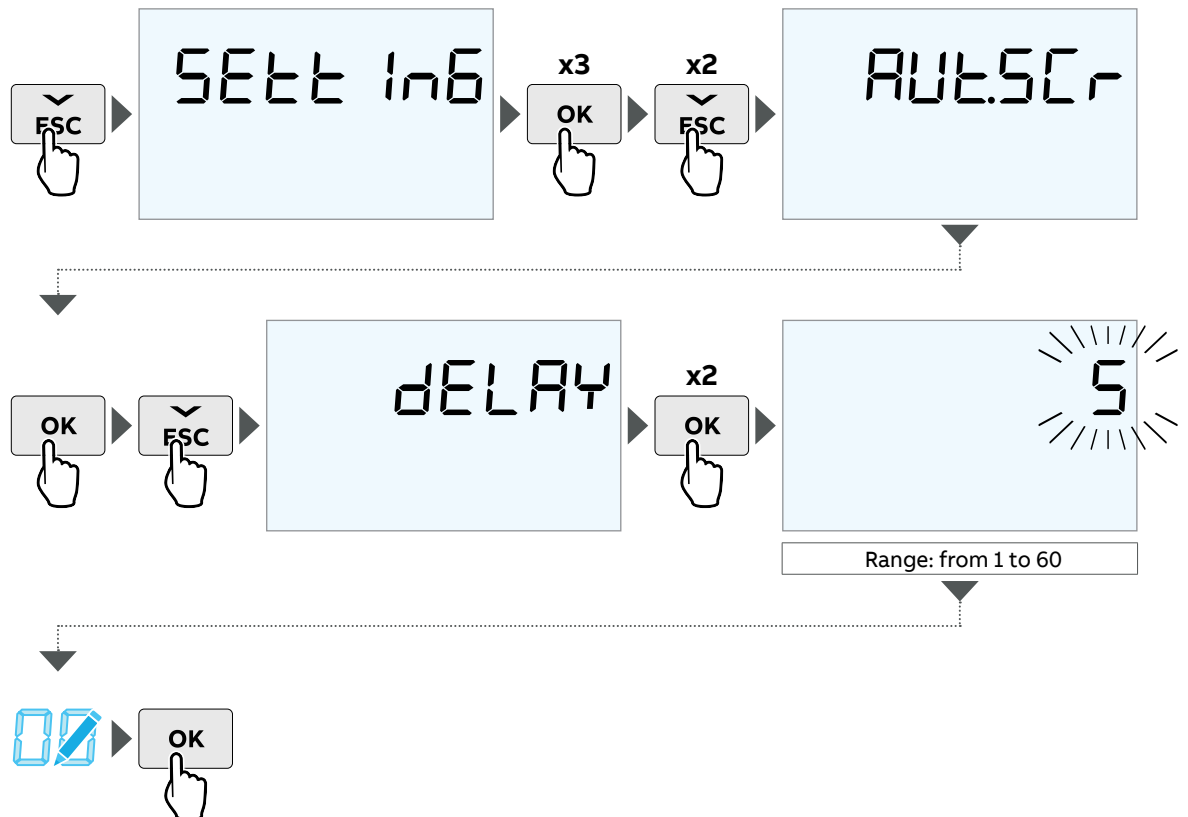

6.7 Setting Currency/CO2

The device allows to set a conversion factor for Currency/CO2, consequently kWh is converted to currency and/or kg CO2.

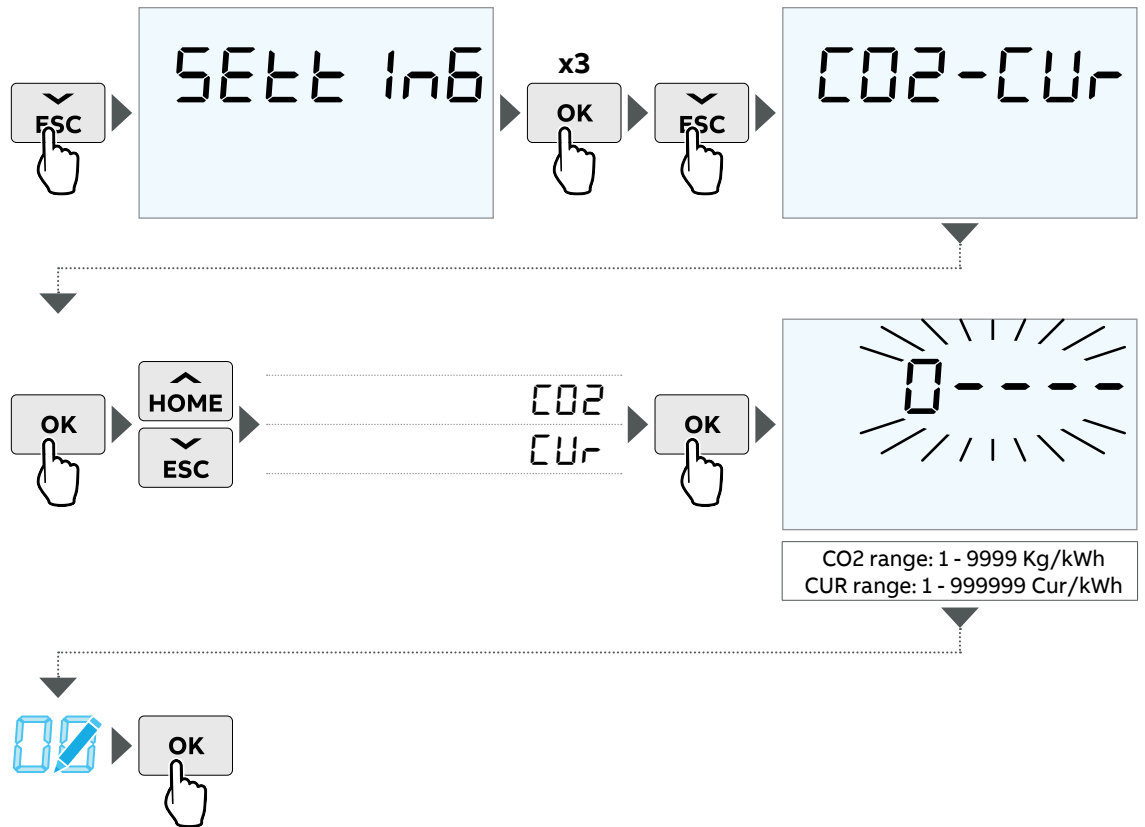

6.8 Setting Wires

To set the number of wires and the type of wiring, perform the following steps (it is possible until 1kWh is reached in MID version):

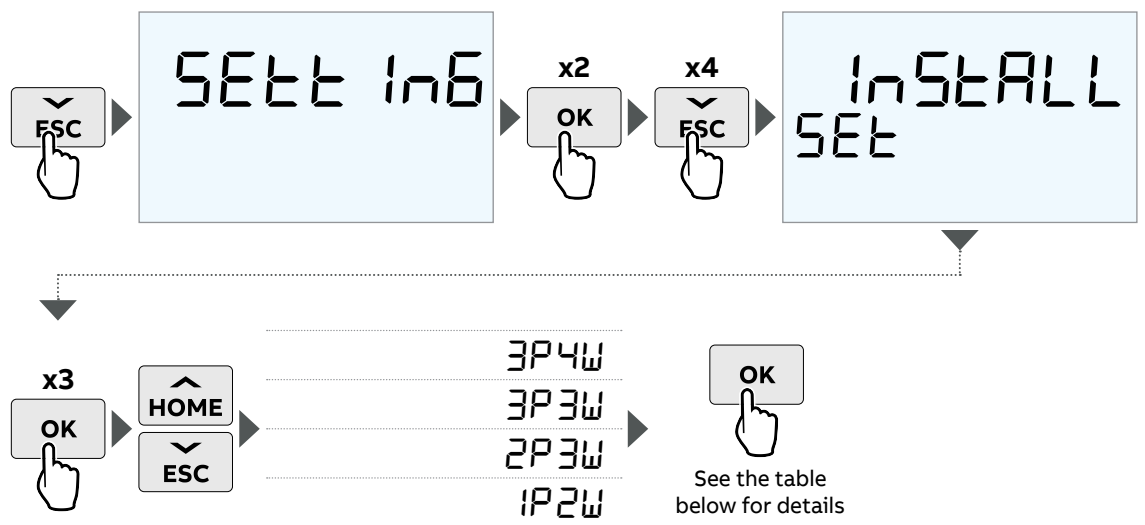

Type of wiring	Number of wires
3 phase	4 wires
	3 wires
2 phase	3 wires
1 phase	2 wires

6.9 Setting I-0

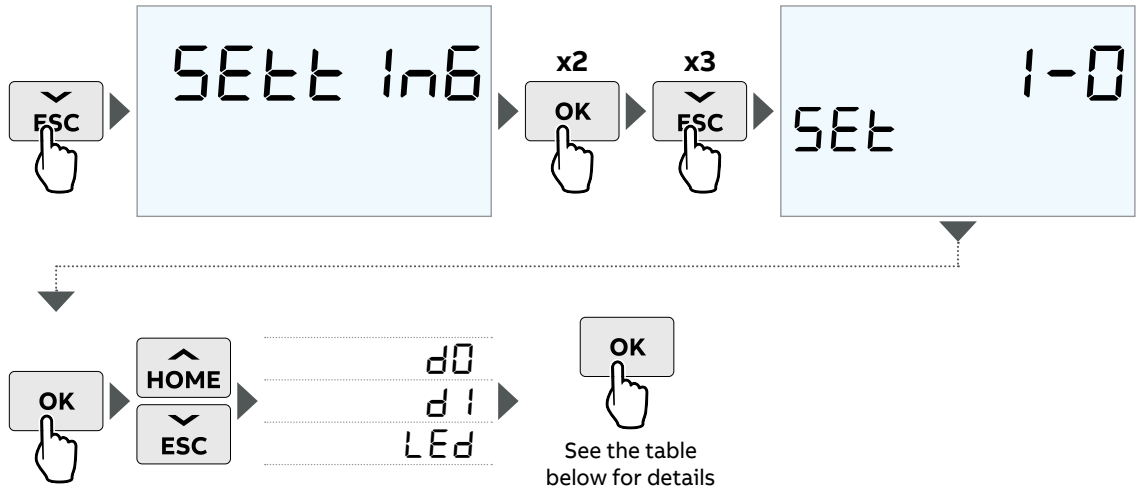

Once you selected the parameter associated with the pulse output the meter will ask to select the pulse frequency (seconds) and the pulse length.

Digital Output Options	
Pulse	Active energy import
	Active energy export
	Reactive energy import
	Reactive energy export
	Inactive
On	
Off	
Alarm	If this option is chosen the meter will subsequently ask to select the alarm slot and confirm
Communication	
Led	
	Active energy import
	Active energy export
	Reactive energy import
	Reactive energy export
	Inactive
Digital Input Options	
Pulse	Pulse ratio
	Unit
Tariff	

For further details see “7.4 Inputs and Outputs”.

6.10 Setting Alarm

See “7.3 Alarm” for alarm definition.

The meter allows to set up alarms on up to 25 different channels, connected to a selectable parameter. The procedure is the same for each of the 25 channels. To configure Alarms, perform the following steps:

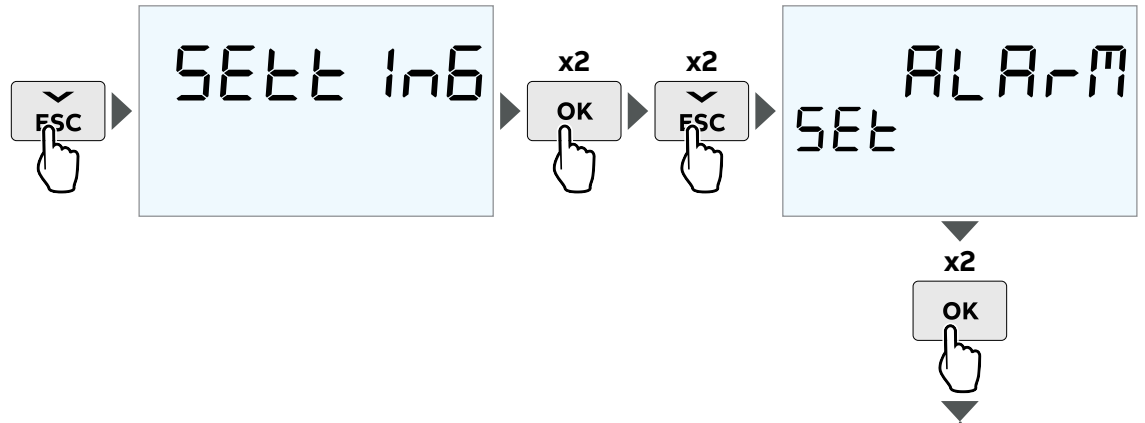

1. Select the channel (1 to 25) in which you want to configure the alarm.
2. Select the parameter (quantity) associated with the channel.

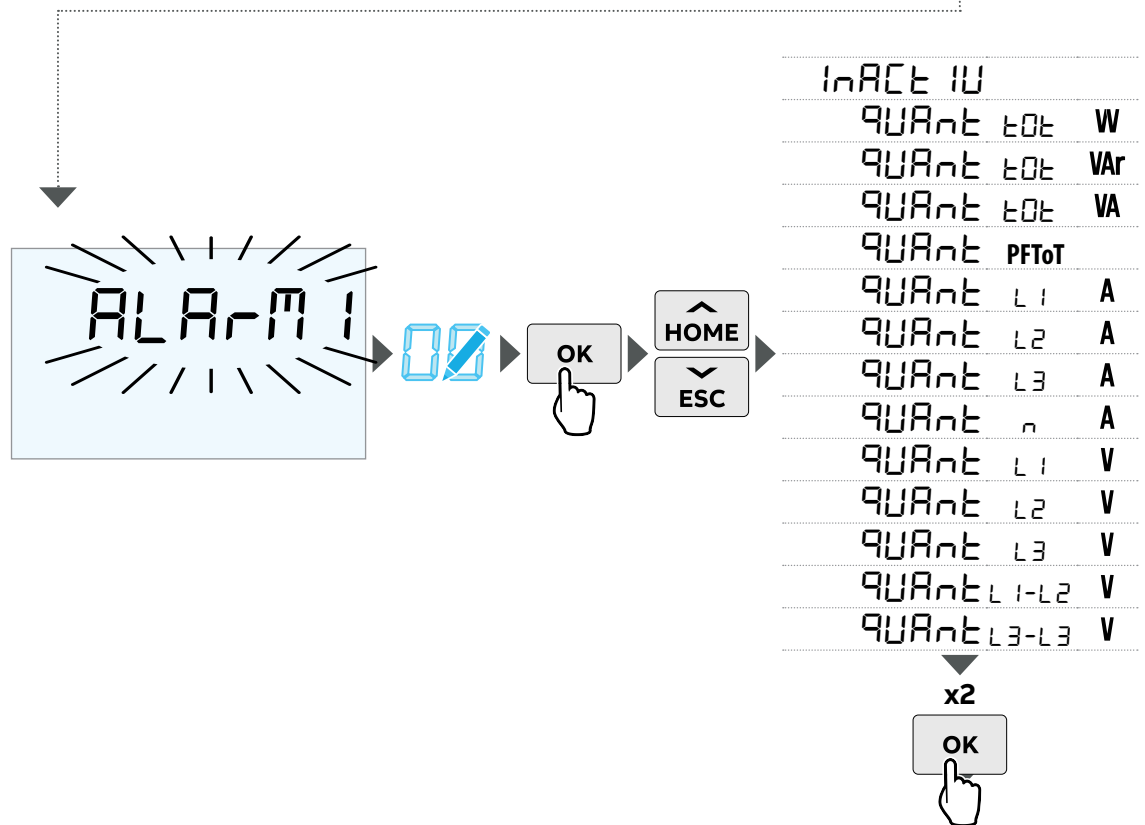

- 3. Select the alarm type, the available options are Cross up and Cross down.
- 4. Select the threshold value connected to the activation of the alarm, depending on the alarm type.

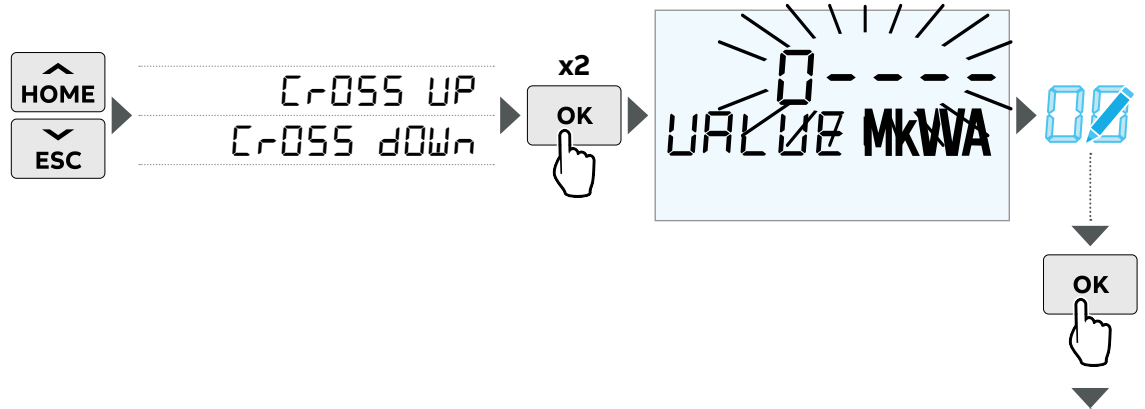

- 5. Select the delay time connected to the activation of the alarm once the value cross up or down the threshold.
- 6. Set the % of the Hysteresys (value from 1 to 40). It represents the percentage of the value below which the measurement must fall before the alarm is deactivated.

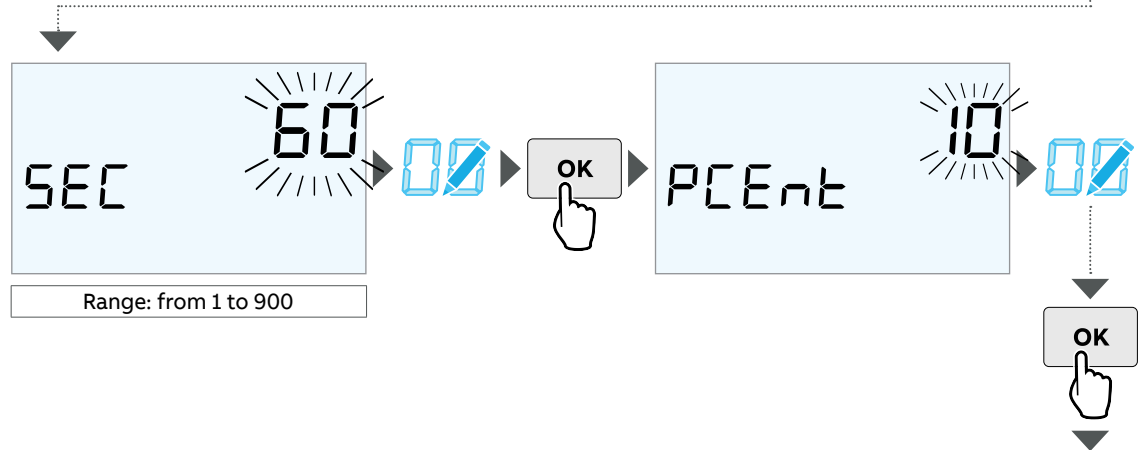

- 7. Select if you want that the alarm will be logged or no.
- 8. The Alarm is now set.

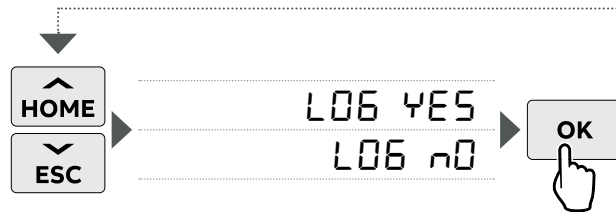

6.11 Setting Tariff

See “7.4 Inputs and Outputs” for further details.

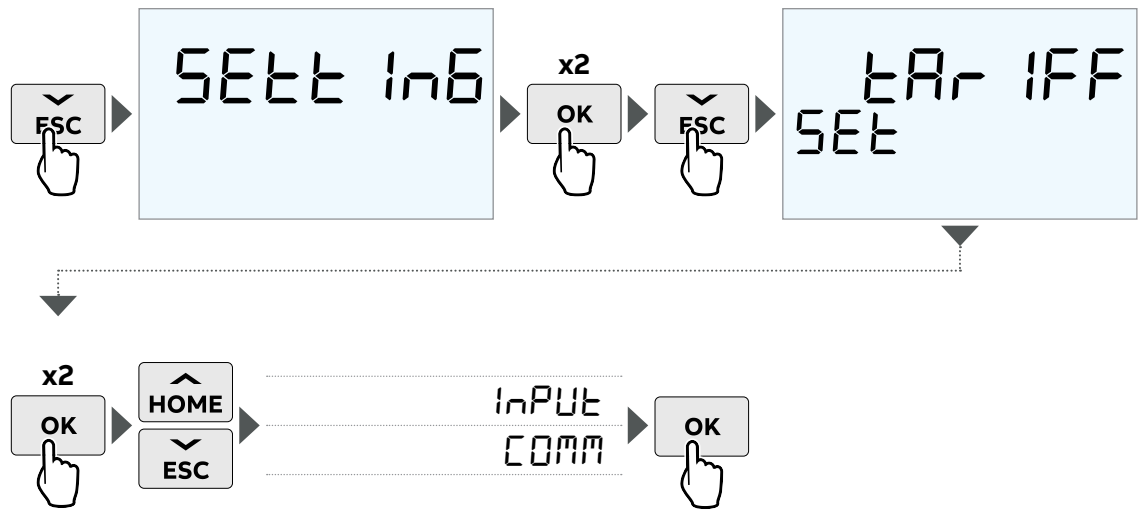

6.12 Setting Modbus communication

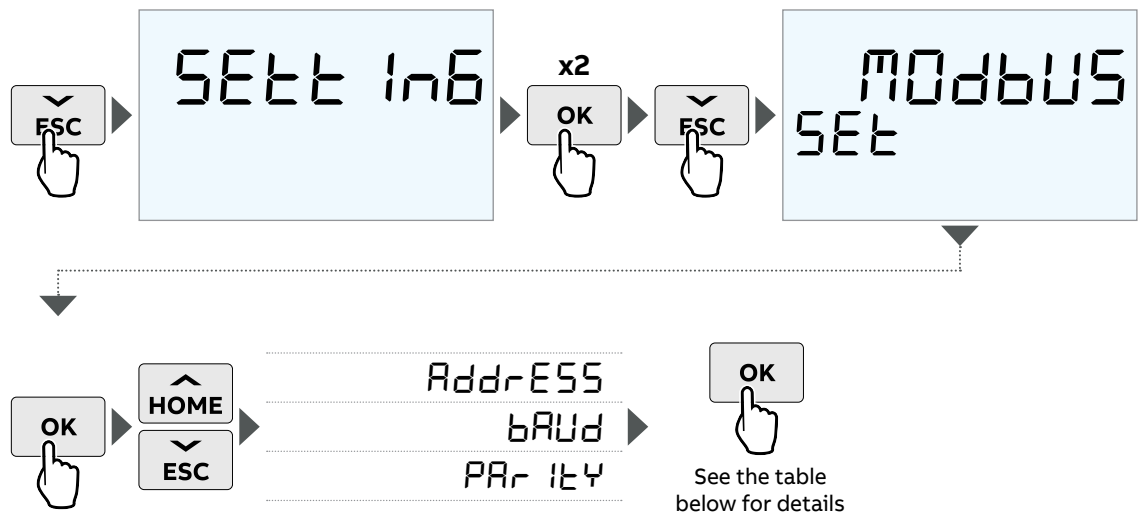

Modbus menu	
Address	1-247
Baud	115200
	57600
	38400
	19200
	9600
	4800
	2400
Parity	1200
	Even
	Odd
	None

6.13 Setting M-bus communication

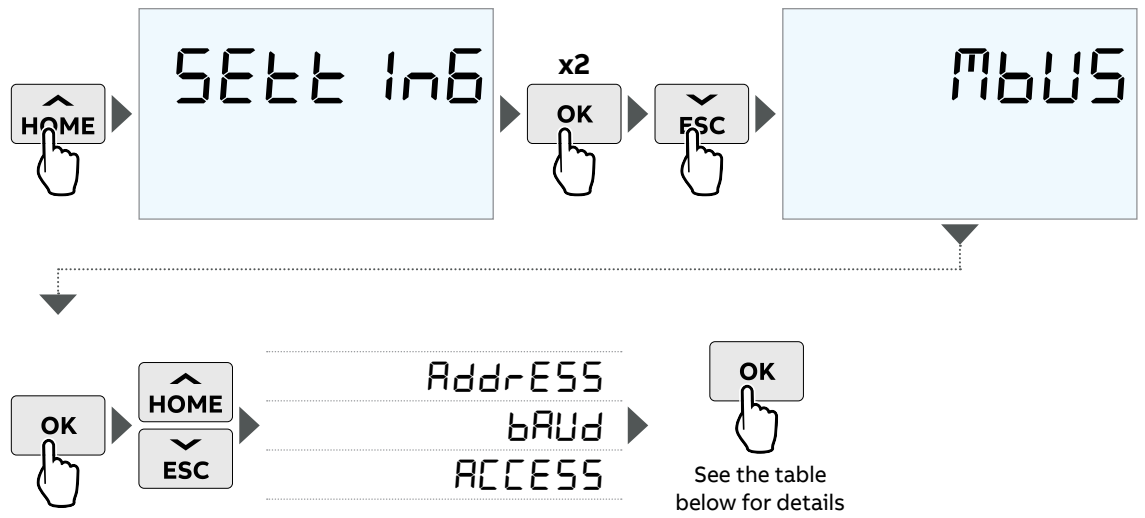

M-Bus menu	
Address	1-250
Baud	9600
	4800
	2400
	1200
	600
Access Level	300
	Open
	Open with password
	Close

7 Technical meter functionalities

This chapter contains technical descriptions of the meter functions.

7.1 Energy Values

The energy values are stored in energy registers. The different energy registers can be divided into:

- Registers containing active, reactive or apparent energy
- Registers containing different tariffs or total sum of all tariffs
- Registers containing energy per phase or total sum of all phases
- Resettable registers (possible to set to zero via buttons or communication command)
- The energy values can be read via communication or directly in the display with the help of the buttons.

Presentation of register values

In D13 direct connected meters the energy is displayed with 7 digits in kWh/ kvarh/KVAh with two decimals and displays one decimal less at overflow, that is it changes to one decimal at 100.000,0 kWh and to no decimals at 1.000.000 kWh.

7.2 Instrumentation functions

Instrumentation	3-phase, 4-wire	3-phase, 3-wire	2-phase, 3-wire (No MID)	1-phase, 2-wire
Active power, total	■	■	■	■
Active power, L1	■	■	■	
Active power, L2	■		■	
Active power, L3	■	■		
Reactive power, Total	■	■	■	■
Reactive power, L1	■		■	
Reactive power, L2	■		■	
Reactive power, L3	■			
Apparent power, Total	■	■	■	■
Apparent power, L1	■	■	■	
Apparent power, L2	■		■	
Apparent power, L3	■	■		
Voltage L1 - N	■		■	■
Voltage L2 - N	■		■	
Voltage L3 - N	■			
Voltage L1 - L2	■	■	■	
Voltage L3 - L2	■	■		
Voltage L1 - L3	■	■		
Current L1	■	■	■	■
Current L2	■	■	■	
Current L3	■	■		
Current N	■		■	
Frequency	■	■	■	■
Power factor, Total	■	■	■	■
Power factor, L1	■	■	■	
Power factor, L2	■		■	
Power factor, L3	■	■		
Cosphi, Total	■	■	■	■
Cosphi, L1	■		■	
Cosphi, L2	■		■	
Cosphi, L3	■			

Instrumentation	3-phase, 4-wire	3-phase, 3-wire	2-phase, 3-wire (No MID)	1-phase, 2-wire
Current quadrant, Total	■	■	■	■
Current quadrant, L1	■		■	
Current quadrant, L2	■		■	
Current quadrant, L3	■			

Accuracy

All instrumentation data accuracy is defined within the voltage range 20 % of the stated nominal voltage and within the current range 5 % of the base current to the maximum current.

The accuracy of all instrumentation data except the frequency is the same as the stated energy metering accuracy. The accuracy for the frequency is 0.5%.

Quantities

Depending on the meter type all or a subset of the following quantities can be monitored:

Voltage L1	Active power L3
Voltage L2	Reactive power Total
Voltage L3	Reactive power L1
Voltage L1-L2	Reactive power L2
Voltage L2-L3	Reactive power L3
Voltage L1-L3	Apparent power total
Current L1	Apparent power L1
Current L2	Apparent power L2
Current L3	Apparent power L3
	Power factor total
Active power total	Power factor L1
Active power L1	Power factor L2
Active power L2	Power factor L3

Minimum registration time

The energy registers are just available if the meter is locked. Energy screens have 7 digits presented in kWh, kVAh, kVArh, according to the quantity. So that, the energy is accumulated up to 9999999 in kWh, kVAh, kVArh. This number of digits allows to accumulate for 4000 h, 24 h operation. After this value, the counter returns to zero. In addition, the user can not reset the energy accumulators by means of any HMI or communication interaction.

7.3 Alarm

The purpose of the alarm function is to enable monitoring of quantities in the meter. Monitoring can be set to high or low level detection. High level detection gives an alarm when the level of a quantity goes above the set level. Low level detection gives an alarm when the value goes below the set level.

It is possible to configure 25 alarms (see "6.10 Setting Alarm"). Configuration can be done via communication or with the pushbuttons directly on the meter.

Functional description

When the value of the monitored quantity passes the reference value for a period of time equal or longer than the specified time delay, the alarm is activated. In the same way, the alarm is deactivated when the value passes the deactivation level and remains there for a time equal or longer than the specified time delay.

If the activation level is higher than the deactivation level, the alarm is activated when the value of the monitored quantity is higher than the activation level.

If the activation level is lower than the deactivation level, the alarm is activated when the value of the monitored quantity is lower than the activation level.

7.4 Inputs and Outputs

Inputs/outputs are built with optocouplers and are galvanically isolated from other meter electronics. They are unidirectional and they handle DC voltage only.

An input that is not connected equals having its voltage off.

The equivalent circuitry of the outputs is an ideal relay in series with a resistor.

See “6.9 Setting I-0” for the configuration.

Pulse Input

The (square) waves of electrical signals that occur in such a short period of time and have a certain width are called “pulses” or “pulse signals”.

The inputs count these pulses, register activity and current status and the data can be read directly on the meter display or via communication. Moreover, register activity can be reset via communication or via the pushbuttons directly on the meter.

Tariff Inputs

See “6.11 Setting Tariff” to set tariffs.

• Tariff control

On meters with tariff functionality, the tariffs are controlled either via communication, or by 1 tariff inputs.

Tariff control via inputs is done by applying a proper combination of “voltage” or “no voltage” to the input(s). Each combination of “voltage”/“no voltage” will result in that the meter will register the energy in a particular tariff register.

In combined meters with both active and reactive metering, both quantities are controlled by the same inputs and the active tariff for active and reactive energy will always be the same.

• Indication of active tariff

The active tariff is displayed on the LCD by the text “Tx” in the status field, where x is the tariff number. The active tariff can also be read via communication.

• Input coding

The coding of the inputs is binary. The following table describes the default coding.

Input 1	Tariff
OFF	= T1
ON	= T2

Pulse Outputs

On the pulse outputs the meter sends out a specified number of pulses (pulse frequency) per kWh (kvarh for reactive pulse outputs).

The output can be controlled by communication or alarm.

The number of pulses is proportional to the energy passing through the meter and length of pulses.

Pulse frequency and pulse length can be set via the pushbuttons on the meter or via communication.

• Pulse frequency

The pulse frequency is configurable and can be set to a value between 1-9999.

Impulses: the value must be an integer.

The unit is selectable and may be set to imp/kWh, imp/Wh or imp/MWh.

• Pulse length

The pulse length can be set to a value between 10-990 ms.

• Deciding pulse frequency/length

If the power is too high for a certain pulse length and pulse frequency, there is a risk that the pulses may go into one another. If this happens the meter will emit a new pulse (relay closed) before the previous one has terminated (relay open) and the pulse will be missed. In worst case the relay may be closed at all times.

To avoid this problem a calculation should be made to work out the maximum pulse frequency allowed at a particular site based upon an estimated maximum power and the meter's pulse output data.

• Formula

The formula to use for this calculation is:

$$\text{Max pulse frequency} = 1000 * 3600 / U / I / n / (P_{\text{pause}} + P_{\text{length}})$$

where U and I is the estimated maximum element voltage (in volts) and current (in amperes), n the number of elements (1 - 3). P_{length} and P_{pause} are the pulse length and the required pulse pause (in seconds). A reasonable minimum pulse length and pulse pause is 30 ms which conforms to the S0 and IEC standard.

Example:

In a direct connected 3-element meter with estimated maximum voltage and current of 250 V and 65 A and pulse length 100 ms and required pulse pause 30 ms, the maximum allowed pulse frequency will be:

$$1000 * 3600 / 250 / 65 / 3 / (0.030 + 0.100) = 568 \text{ impulses / kWh (kvarh)}$$

7.5 Logs

The D13 meter contains two types of different logs:

- Event Log
- Audit Log

Event Log

Event Log include Error, Warning and Alarm.

Event Log can be read via communication or directly in the display of the meter.

A maximum of 200 log events can be stored in the Event Log. When the maximum number of events for a log is reached, the oldest events will be overwritten. It is possible to delete all entries in the Event Log via communication.

This log stores events that relate to alarms, errors and configuration warnings.

The following information is stored in an event:

- Event Code
- Duration

The following events are stored in this log:

• Error

- Program CRC Error - Error when checking firmware consistency
- Persistent Storage Error - Data stored in long-term memory is corrupt

• Warning

- Negative Power Element 1 Warning - Element 1 measures negative power
- Negative Power Element 2 Warning - Element 2 measures negative power
- Negative Power Element 3 Warning - Element 3 measures negative power
- Negative Total Power Warning - Total power is measured as negative
- U1 Missing Warning - U1 is missing
- U2 Missing Warning - U2 is missing
- U3 Missing Warning - U3 is missing
- Frequency Warning - Net frequency is not stable

• Alarm

- Alarm Current L1
- Alarm Current L2
- Alarm Current L3
- Alarm Current Neutral
- Alarm Active Power Total
- Alarm Active Power L1
- Alarm Active Power L2
- Alarm Active Power L3
- Alarm Reactive Power total
- Alarm Reactive Power L1
- Alarm Reactive Power L2
- Alarm Reactive Power L3
- Alarm Apparent power Total
- Alarm Apparent power L1
- Alarm Apparent power L2
- Alarm Apparent power L3
- Alarm Power Factor Total
- Alarm Power Factor L1
- Alarm Power Factor L2
- Alarm Power Factor L3
- Alarm Voltage L1
- Alarm Voltage L2
- Alarm Voltage L3
- Alarm Voltage L1-L2
- Alarm Voltage L2-L3
- Alarm Voltage L1-L3

Audit Log

Audit Log tracks important events like firmware upgrade, password changes, reset, etc.

A maximum of 923 log events can be stored in the Audit Log.

When the maximum number of events for this log is reached, no more events can be stored and an “Audit Log error” is shown on display.

A new firmware upgrade attempt will be unsuccessful because no more log events can be stored.

The following information is stored in an event:

- Item number;
- Count of FW upgrades
- Firmware version
- Wiring setup index
- Active Energy import
- Active Energy import L1
- Active Energy import L2
- Active Energy import L3
- Active Energy import Tariff 1
- Active Energy import Tariff 2
- Active Energy import Tariff 3
- Active Energy import Tariff 4
- Active Energy Export
- Lifetime counter snapshot of audit log
- Source identifier of FW upgrade
- Success state of fw upgrade
- Counter of failed fw upgrades

8 Measurement methods

This chapter contains information about measurement theory and the most common used measurement methods. The information can be used to better understand the meter behavior and/or to pick the correct measurement method.

8.1 Measuring Energy and power

Active energy

It is easy to understand the need for a utility to measure active energy, since the information is necessary to bill the customer correctly. Usually the more energy the customer consumes the higher the accuracy of the meter needs to be. Normally 4 accuracy classes are used: 2%- (small consumers, e.g. households), 1%-, 0.5%-and 0.2%-meters with defined power levels for each class.

Also from a customer point of view it is easy to understand the need to measure the active energy as it can give him information about where and when energy is consumed. This information can then be used to take measures to decrease the consumption and thereby the cost.

In some cases it is desired to simplify the measurement. In such cases simplified methods can be used of which the most common are described in this chapter. These methods most often require a balanced load, which means that the impedance is the same in all phases giving the same current amplitude and power factor in all phases.



It should be mentioned that even if the load is perfectly balanced the accuracy will be decreased if the incoming voltages are not the same on all phases.

Active energy is calculated as the time integral of the product of voltage and current for all measured elements 1, 2 etc summed together, see below.

$$\text{Active energy} = \int (U_1(t) \cdot I_1(t) + U_2(t) \cdot I_2(t) \dots) \cdot dt$$

Today basically all energy meters are digital and uses analog-to-digital converters (ADC's) where the voltages and currents are sampled and the time integral instead becomes a summation of the product of voltage and current samples and time T between samples for all measured elements, see below.

$$\text{Active energy} = \sum_k (U_1(k) \cdot I_1(k) + U_2(k) \cdot I_2(k) \dots) \cdot T$$

Active energy is divided into import and export, where import is energy delivered from the power source (normally utility) to the load of the customer, and export is energy going in the opposite direction, that is from the customer out to the mains net. Customer power sources can for example be solar panels.

The difference between import and export energy is the net energy.

Beside measuring the total active energy also the individual energy in each measuring element can be measured, where a measuring element normally is the phase energy.

Active power

Active power is calculated by continuously taking snapshots of the active energy measured and dividing the energy increment with the time passed between the snapshots, see formula below where E_k and E_{k+1} are two successive active energy snapshots and T is the time passed between the snapshots, where T is a complete number of mains line cycles. Active power can be positive (import) or negative (export) depending on the direction of the active energy flow.

$$\text{Active power} = (E_{k+1} - E_k) / T$$

In case no harmonics is present and the load is fixed the active power on each phase can be calculated as:

$$P = U_{\text{rms}} * I_{\text{rms}} * \cos \varphi$$

where φ is the phase angle between the voltage and the current.

Reactive energy

Sometimes there is also a need to measure the reactive energy. Consumer equipment often introduces a phase shift between current and voltage due to the fact that the load has a more or less reactive component, for example motors that have an inductive component. A reactive load will increase the current which means that the power source generator and the size of the power lines have to increase which in turn means higher cost for the utility. A higher current also means that the line losses increase.

Because of that the maximum permissible phase shift is sometimes governed in the terms of the contract that the consumer have with the power supplier. If the consumer exceeds a specified maximum reactive load, he will be liable for an extra charge. This type of contract will require a utility meter that measures reactive energy and/or power.

Also, from the customer's point of view, it may be of some interest to measure reactive energy/power since it gives knowledge about the nature of the load. That is, how big the different loads are and how they vary over time. This knowledge can be used in the planning how to decrease the reactive power/energy to decrease the electricity bill.

The reactive energy measured is the energy contained in the fundamental mains frequency, as stipulated in the IEC standards for reactive energy. Harmonics in the voltage and current will thus not influence the amount of reactive energy.

Reactive energy is calculated as a summation of all measured elements as the product of voltage and current fundamental rms values and the phase angle between the voltages and currents, which is the reactive power, multiplied by the rms measurement time T , which is a number of complete mains line cycles, see formula below.

$$\text{Reactive energy} = \sum_k (U1_k \cdot I1_k \cdot \sin(\varphi1) + U2_k \cdot I2_k \cdot \sin(\varphi2) + \dots) \cdot T$$

Reactive power

As mentioned above the reactive energy is calculated by multiplying the reactive power by the time passed in the measurement of the fundamental rms values and the phase angle between the voltages and currents. Thus the calculation of the reactive power is the same as for the energy with the exception that the multiplication of the time passed is omitted, see formula below. The measurement is done in a complete number of mains line cycles. Reactive power can be positive (import) or negative (export) depending on the direction of the reactive energy flow.

$$\text{Reactive power} = \sum_k (U1_k \cdot I1_k \cdot \sin(\varphi1) + U2_k \cdot I2_k \cdot \sin(\varphi2) + \dots)$$

Apparent energy

Apparent energy is calculated as a summation of all measured elements as the product of voltage and current rms values and the rms measurement time T, which is a number of complete mains line cycles, see formula below. Thus it is not affected by the phase shift between current and voltage. As for reactive energy it can sometimes be used for billing in case the power factor is lower than a certain value.

$$\text{Apparent energy} = \sum_k (U_{1_k} \cdot I_{1_k} + U_{2_k} \cdot I_{2_k} + \dots) \cdot T$$

Apparent power

As mentioned above the apparent energy is calculated by multiplying the apparent power by the time passed in the measurement of the fundamental rms values. Thus the calculation of the apparent power is the same as for the energy with the exception that the multiplication of the time passed is omitted, see formula below. The measurement is done in a complete number of mains line cycles. Apparent is by definition always positive.

$$\text{Apparent power} = \sum_k (U_{1_k} \cdot I_{1_k} + U_{2_k} \cdot I_{2_k} + \dots)$$

Resistive, inductive and capacitive loads

Resistive loads don't give rise to any phase shifts. Inductive loads have phase shift in one direction with the current lagging the voltage, while capacitive loads produces a phase shift in the opposite direction with the current leading the voltage. As a result, inductive and capacitive loads can be used to compensate each other.

The illustration below shows a vector diagram for resistive, inductive and capacitive loads:

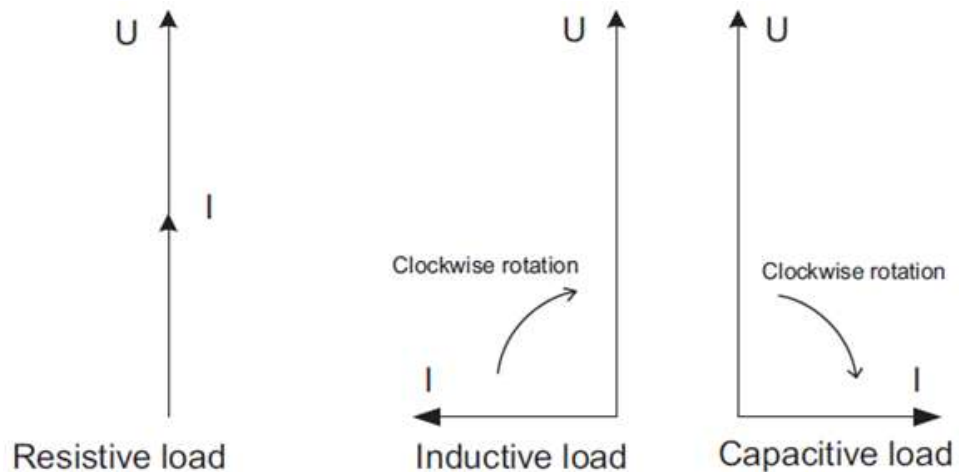

Phase displacement

A load that consumes both reactive and active energy can be divided into active and reactive components. The angle between the apparent power ($U \cdot I$) vector and the active power component is described as phase displacement angle or power factor angle.

The illustration below shows a vector diagram for a load with an active and a reactive component with no harmonics present.

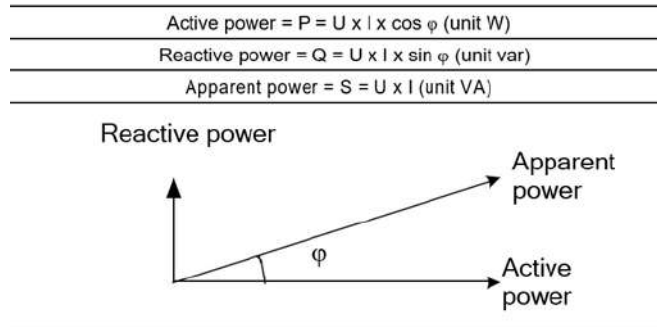

Power factor and $\cos \varphi$

Power factor is defined as the ratio between active power P and apparent power S , see below.

$$\text{Power factor} = P / S$$

$\cos \varphi$ is defined as the ratio of the fundamental active power to the fundamental apparent power, which is the same as cosine for the phase angle between the fundamental voltage and fundamental current, see below.

$$\cos \varphi = \cos(\text{U-to-I-angle})$$

Thus the difference between power factor and $\cos \varphi$ is that the power factor includes all harmonics while $\cos \varphi$ only considers the fundamental mains frequency.

The 4 power quadrants

The type of load can be represented geometrically by four quadrants. In the first quadrant the load is inductive and active energy is imported (energy is delivered from the utility to the customer). In the second quadrant the load is capacitive and active energy is exported and reactive energy is imported. In the third quadrant the load is inductive and active energy is exported. In the last quadrant the load is capacitive and active energy is imported and reactive energy is exported.

The type of load can be represented geometrically by 4 power quadrants, see figure below.

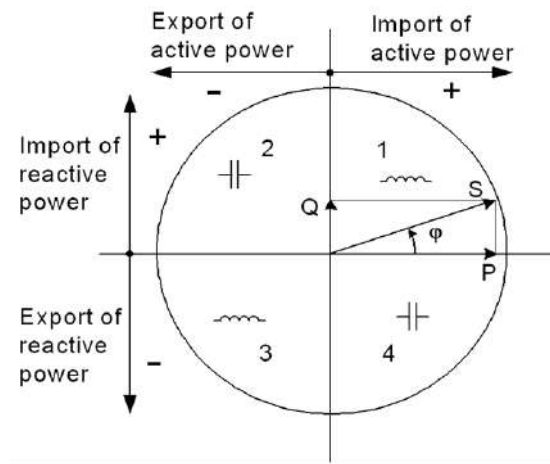

8.2 Single phase metering

Single phase metering in a 2-wire system

In a 2-wire installation a single phase meter is used. Normally the 2 wires are a phase voltage and the neutral.

The active energy consumed by the load is the product of momentary voltage and current integrated over the desired measuring time period.

The illustration below shows a direct connected single phase meter measuring the active energy (E) consumed by a load.

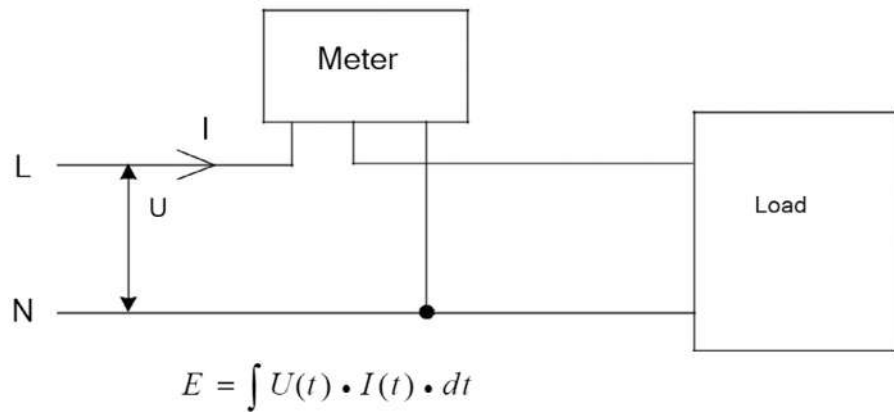

Single phase metering in a 4-wire system

In a 4-wire system a single phase meter can sometimes be used to measure the energy consumed in one phase, and multiply by 3 to get the total energy consumed. This method only gives correct results in a balanced system (same voltage, current and power factor in all phases). This method should not be used for accurate measurement, but can be used when high accuracy is not needed.

The illustration below shows single phase metering in a 3-phase system.

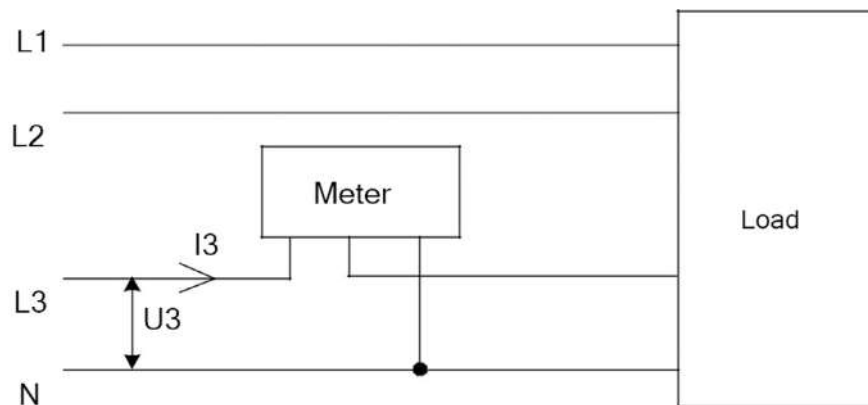

8.3 3-Phase 3-wire metering

The 3-phase 3-wire metering method is used in systems with 3 wires, normally a 3-phase system that does not have a neutral conductor. 3-phase 3-wire metering can be used irrespectively of the load being balanced or not.

In 3-wire metering the L2 voltage is used as the voltage reference and the voltage difference between that voltage and the L1 and L3 voltage are measured and multiplied by its respective current. The active energy consumed by the load is the product of momentary voltages U1-U2 and U3-U2 and the currents I1 and I3 integrated over the desired measuring time period.

The diagram below shows a 3-phase 3-wire meter measuring the active energy (E) consumed by a load.

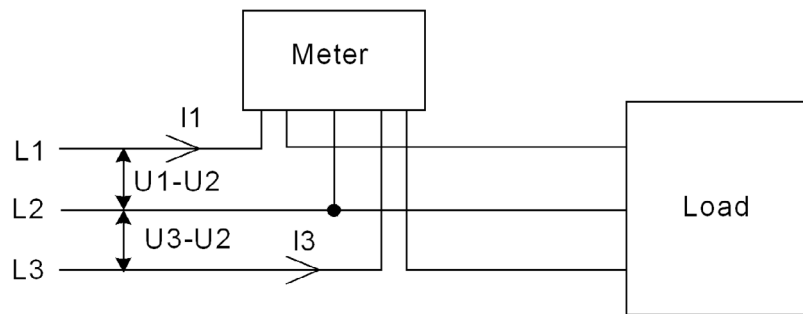

$$E = \int ((U1(t) - U2(t)) \cdot I1(t) + (U3(t) - U2(t)) \cdot I3(t)) \cdot dt$$

If no harmonics is present and the rms values of the voltages and currents are constant, the total active power can be expressed as:

$$P_{tot} = P1 + P3 = (U1-U2) \times I1 \times \cos \phi_{12} + (U3-U2) \times I3 \times \cos \phi_{32}$$

where ϕ_{12} is the phase angle between the (U1-U2) voltage and the I1 current and ϕ_{32} is the phase angle between the (U3-U2) voltage and the I3 current.

The vector diagram below shows the vectors for the phase voltages U1, U2 and U3, the phase currents I1, I2 and I3 and the phase-to-phase voltages U1-U2 and U3-U2 for a pure resistive load where the phase currents are in phase with its respective phase voltages.

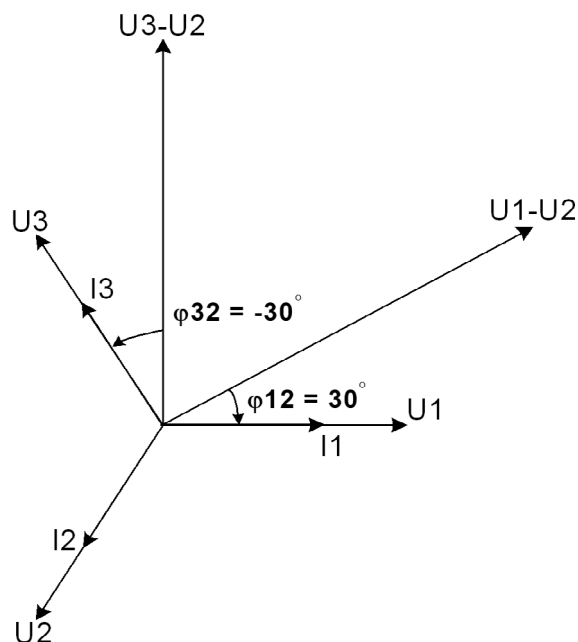

3-phase 3-wire metering in a 4-wire system

3-phase 3-wire metering can also be used in a 4-wire system if the current in the neutral connection is zero. Applying this method in a system having a non-zero neutral current will decrease the accuracy, but can sometimes be justified if the current is small compared to the line currents or if high accuracy is not required.

8.4 3-Phase 4-wire metering

This method is normally used in 3-phase systems that have a neutral conductor.

In a 3-phase 4-wire meter the neutral voltage is used as the voltage reference and the voltage difference between the neutral voltage and the L1, L2 and L3 voltages are measured and multiplied by its respective current. The active energy consumed by the load is the product of momentary voltages U_1 , U_2 and U_3 and the currents I_1 , I_2 and I_3 integrated over the desired measuring time period.

The picture below shows a direct connected 3-phase 4-wire meter measuring the active energy (E) consumed by a load.

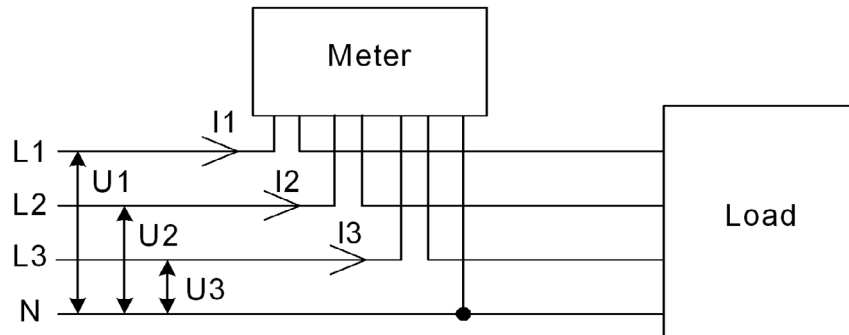

$$E = \int (U_1(t) \cdot I_1(t) + U_2(t) \cdot I_2(t) + U_3(t) \cdot I_3(t)) \cdot dt$$

In the case where no harmonics are present and the rms values of the voltages and currents are constant, the total active power can be expressed as:

$$P_{tot} = P_1 + P_2 + P_3 = U_1 \times I_1 \times \cos \phi_1 + U_2 \times I_2 \times \cos \phi_2 + U_3 \times I_3 \times \cos \phi_3$$

where ϕ_1 , ϕ_2 and ϕ_3 is the phase angles between the phase voltage and its respective current.

9 Service & Maintenance

9.1 Service

This product contains no parts that can be repaired or exchanged. A broken meter must be replaced. If you need assistance please contact ABB.

Do not open the meter case and do not attempt to repair any component. Opening the meter will void accuracy and calibration.

9.2 Event codes

The following table describes the event codes that may occur in the Event log:

Error Codename-description	Text [Row1,Row2]	Code
ERROR_AUDIT_LOG, LOG_ERROR_AUDIT_LOG	AUdIt, LOg	40
ERROR_PROGRAM_CRC, LOG_ERROR_PROGRAM_CRC	Prog, CrC	41
ERROR_PERSISTENT_STORAGE, LOG_ERROR_PERSISTENT_STORAGE	PErSISt, Strg	42
ERROR_RAM_CRC, LOG_ERROR_RAM_CRC	rAM, CrC	43
ERROR_FW_UP_INV_IMAGE, LOG_ERROR_FW_UP_INV_IMAGE	InV.IMg, FWw	44
ERROR_FW_UP_MAX_COUNT, LOG_ERROR_FW_UP_MAX_COUNT	MAX.Cnt, FWw	45
ERROR_FW_UP, LOG_ERROR_FW_UP	FW UP, FWw	46
ERROR_FW_UP_MAX_INV_IMG_COUNT, LOG_ERROR_FW_UP_MAX_INV_IMG_COUNT	InV.Cnt, FWw	47
ERROR_ABB_SPECIFIC_STR_6, LOG_ERROR_ABB_SPECIFIC_STR_6	AbbStr, 7	48
ERROR_ABB_SPECIFIC_STR_7, LOG_ERROR_ABB_SPECIFIC_STR_7	AbbStr, 8	49
ERROR_ABB_SPECIFIC_STR_8, LOG_ERROR_ABB_SPECIFIC_STR_8	AbbStr, 9	50
ERROR_ACREF, LOG_ERROR_ACREF	ACrEF,	51
ERROR_MAINBOARDTEMP_SENSOR, LOG_ERROR_MAINBOARDTEMP_SENSOR	SEnSO, tMmP	52
ERROR_RTC_CIRCUIT, LOG_ERROR_RTC_CIRCUIT	ClrC, rtC	53

Warning Codename-description	Text [Row1,Row2]	Code
WARNING_U1_LOW, LOG_WARNING_U1_LOW	LOW, U1	1000
WARNING_U2_LOW, LOG_WARNING_U2_LOW	LOW, U2	1001
WARNING_U3_LOW, LOG_WARNING_U3_LOW	LOW, U3	1002
WARNING_MID_NOT_LOCKED, LOG_WARNING_MID_NOT_LOCKED	UNLOCK, MId	1003
WARNING_NEG_POW_ELEMENT_1, LOG_WARNING_NEG_POW_ELEMENT_1	NEg.POW, L1	1004
WARNING_NEG_POW_ELEMENT_2, LOG_WARNING_NEG_POW_ELEMENT_2	NEg.POW, L2	1005
WARNING_NEG_POW_ELEMENT_3, LOG_WARNING_NEG_POW_ELEMENT_3	NEg.POW, L3	1006
WARNING_NEG_TOT_POW, LOG_WARNING_NEG_TOT_POW	NEg.POW, tot	1007
WARNING_FREQUENCY, LOG_WARNING_FREQUENCY	FrEq,	1008
WARNING_NOT_USED2, LOG_WARNING_NOT_USED2	nOt.USE, 2	1009
WARNING_DATE_NOT_SET, LOG_WARNING_DATE_NOT_SET	UnSEt, dAtE	1010
WARNING_TIME_NOT_SET, LOG_WARNING_TIME_NOT_SET	UnSEt, tIMm	1011
WARNING_U2_CONNECT, LOG_WARNING_U2_CONNECT	COnnECt, U2	1012
WARNING_U3_CONNECT, LOG_WARNING_U3_CONNECT	COnnECt, U3	1013
WARNING_I1_MISSING, LOG_WARNING_I1_MISSING	MISSIng, I1	1014
WARNING_I2_MISSING, LOG_WARNING_I2_MISSING	MISSIng, I2	1015
WARNING_I3_MISSING, LOG_WARNING_I3_MISSING	MISSIng, I3	1016
WARNING_I2_CONNECT, LOG_WARNING_I2_CONNECT	COnnECt, I2	1017
WARNING_I3_CONNECT, LOG_WARNING_I3_CONNECT	COnnECt, I3	1018

WARNING_PHASE1_CONNECTED_TO_NEUTRAL, LOG_WARNING_PHASE1_CONNECTED_TO_NEUTRAL	tO_NEUt, PHASE1	1021
WARNING_PHASE2_CONNECTED_TO_NEUTRAL, LOG_WARNING_PHASE2_CONNECTED_TO_NEUTRAL	tO_NEUt, PHASE2	1022
WARNING_PHASE3_CONNECTED_TO_NEUTRAL, LOG_WARNING_PHASE3_CONNECTED_TO_NEUTRAL	tO_NEUt, PHASE3	1023
WARNING_PULSES_MERGED_1, LOG_WARNING_PULSES_MERGED_1	MErgEd, PULSE1	1024
WARNING_PULSES_MERGED_2, LOG_WARNING_PULSES_MERGED_2	MErgEd, PULSE2	1025
WARNING_POWERFAIL, LOG_WARNING_POWERFAIL	POWEr, FAIL	1030

Alarm Codename-description	Text [Row1,Row2]	Code
ALARM_1_ACTIVE, LOG_ALARM_1	ALArM, 1	2013
ALARM_2_ACTIVE, LOG_ALARM_2	ALArM, N	2014
ALARM_3_ACTIVE, LOG_ALARM_3	ALArM, N	2015
ALARM_4_ACTIVE, LOG_ALARM_4	ALArM, N	2016
ALARM_5_ACTIVE, LOG_ALARM_5	ALArM, N	2017
ALARM_6_ACTIVE, LOG_ALARM_6	ALArM, N	2018
ALARM_7_ACTIVE, LOG_ALARM_7	ALArM, N	2019
ALARM_8_ACTIVE, LOG_ALARM_8	ALArM, N	2020
ALARM_9_ACTIVE, LOG_ALARM_9	ALArM, N	2021
ALARM_10_ACTIVE, LOG_ALARM_10	ALArM, N	2022
ALARM_11_ACTIVE, LOG_ALARM_11	ALArM, N	2023
ALARM_12_ACTIVE, LOG_ALARM_12	ALArM, N	2024
ALARM_13_ACTIVE, LOG_ALARM_13	ALArM, N	2025
ALARM_14_ACTIVE, LOG_ALARM_14	ALArM, N	2026
ALARM_15_ACTIVE, LOG_ALARM_15	ALArM, N	2027
ALARM_16_ACTIVE, LOG_ALARM_16	ALArM, N	2028
ALARM_17_ACTIVE, LOG_ALARM_17	ALArM, N	2029
ALARM_18_ACTIVE, LOG_ALARM_18	ALArM, N	2030
ALARM_19_ACTIVE, LOG_ALARM_19	ALArM, N	2031
ALARM_20_ACTIVE, LOG_ALARM_20	ALArM, N	2032
ALARM_21_ACTIVE, LOG_ALARM_21	ALArM, N	2033
ALARM_22_ACTIVE, LOG_ALARM_22	ALArM, N	2034
ALARM_23_ACTIVE, LOG_ALARM_23	ALArM, N	2035
ALARM_24_ACTIVE, LOG_ALARM_24	ALArM, N	2036
ALARM_25_ACTIVE, LOG_ALARM_25	ALArM, 25	2037

9.3 Cleaning

If the meter needs to be cleaned, then use a lightly moistened cloth with a mild detergent to wipe it.



Be careful that no liquid gets into the meter since it can ruin the equipment.

10 Communication manual

10.1 QR Code



A series of horizontal dotted lines spanning the width of the page, intended for writing or drawing.

A series of horizontal dotted lines spanning the width of the page, intended for writing or drawing.

A series of horizontal dotted lines spanning the width of the page, intended for writing or drawing.

A series of horizontal dotted lines spanning the width of the page, intended for writing or drawing.



ABB S.p.A

Electrification business
Viale dell'Industria, 18
20009 Vittuone (MI) Italy
new.abb.com/low-voltage

