

9AKK107492A7829 | Nov 2019

KNX Technical Reference Manual

ABB i-bus® KNX Caldion®

CAR/U4.1.1.1-xx Caldion® Room Temperature Controller,
2/4 pipe, On/Off, FM

CAR/U4.2.1.1-xx Caldion® Room Temperature Controller,
2/4 pipe, 0~10V, FM

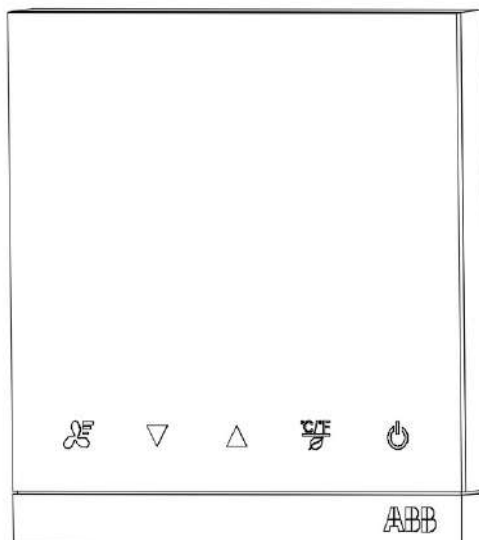

| | | |
|--------|---|----|
| 1 | Information on the manual..... | 12 |
| 1.1 | General information | 12 |
| 1.2 | Structure of the manual..... | 12 |
| 1.3 | Legal disclaimer | 12 |
| 1.4 | Symbol of the manual | 13 |
| 2 | Safety | 14 |
| 2.1 | Intended use | 14 |
| 2.2 | Improper use..... | 14 |
| 2.3 | Target groups and qualifications | 14 |
| 2.4 | Liability and warranty | 14 |
| 3 | Environment | 15 |
| 4 | Function..... | 16 |
| 4.1 | Fan coil unit overview | 16 |
| 4.2 | Functional overview | 16 |
| 4.3 | Input function | 17 |
| 4.4 | Output function..... | 17 |
| 5 | Overview of devices | 18 |
| 5.1 | Front – Picture of product | 18 |
| 5.2 | Rear – Picture of product..... | 19 |
| 5.3 | Bottom – Picture of product | 19 |
| 6 | Technical data | 20 |
| 7 | Circuit diagrams and dimensional drawings | 22 |
| 7.1 | 2 pipes on/off | 22 |
| 7.2 | 2 pipes on/off with electrical heater..... | 22 |
| 7.3 | 2 pipes on/off 3 point..... | 23 |
| 7.4 | 4 pipes on/off | 23 |
| 7.5 | 2 pipes 0~10V..... | 24 |
| 7.6 | 2 pipe 0~10V with electrical heater | 24 |
| 7.7 | 4 pipes 0~10V..... | 25 |
| 7.8 | Dimensional drawing:..... | 26 |
| 8 | Installation and electrical connection | 27 |
| 8.1 | Requirements for the electricians..... | 27 |
| 8.2 | Mounting | 28 |
| 8.2.1 | Installation consideration | 28 |
| 8.2.2 | Installation of the device | 30 |
| 8.3 | Wiring illustration..... | 32 |
| 8.3.1 | On/Off wiring illustration..... | 32 |
| 8.3.2 | 0~10V wiring illustration..... | 32 |
| 8.4 | Topology illustration | 33 |
| 8.4.1 | KNX network topology illustration | 33 |
| 8.4.2 | Standalone topology illustration | 33 |
| 9 | Commissioning | 34 |
| 9.1 | Network mode (software)..... | 35 |
| 9.1.1 | Preparatory steps | 35 |
| 9.1.2 | Assigning a physical address..... | 35 |
| 9.1.3 | Assigning the group address(es) | 35 |
| 9.1.4 | Selecting the application program..... | 35 |
| 9.1.5 | Differentiating the application program | 36 |
| 9.2 | Standalone Mode..... | 36 |
| 10 | Operation..... | 37 |
| 10.1 | Control buttons..... | 37 |
| 10.1.1 | On/Off RTC and setting of operating mode..... | 37 |
| 10.1.2 | °C/°F switching and ECO mode..... | 37 |

| | | |
|---------|--|----|
| 10.1.3 | Setting of the setpoint temperature..... | 37 |
| 10.1.4 | Setting of Fan speed..... | 37 |
| 11 | Cleaning..... | 38 |
| 12 | Maintenance..... | 38 |
| 13 | Description of applications / Objects..... | 39 |
| 13.1 | Overview of parameters..... | 39 |
| 13.2 | Parameters..... | 39 |
| 13.2.1 | General – Sending and switching delay after 230V recovery..... | 39 |
| 13.2.2 | General – State after sending and switching has elapsed..... | 39 |
| 13.2.3 | General – Limited number of telegrams..... | 40 |
| 13.2.4 | General – Maximum number of telegrams..... | 40 |
| 13.2.5 | General – In period..... | 40 |
| 13.2.6 | General – Enable group object "In operation", 1 bit..... | 41 |
| 13.2.7 | General – Value to be send cyclic for "In operation"..... | 41 |
| 13.2.8 | General – Sending cycle time..... | 41 |
| 13.2.9 | General – Display illumination..... | 41 |
| 13.2.10 | General – Display illumination activate / deactivate by group object..... | 42 |
| 13.2.11 | General – Time for display illumination to turn off after last trigger. | 42 |
| 13.2.12 | General – Button icon LED illumination..... | 42 |
| 13.2.13 | General – Button icon LED illumination activate / deactivate by group object..... | 42 |
| 13.2.14 | General – Time for button icon LED illumination to turn off after last trigger..... | 43 |
| 13.2.15 | General – Button icon first touch function when device is in standby mode..... | 43 |
| 13.2.16 | General – On/Off button control function..... | 43 |
| 13.2.17 | General – Behavior after switching on..... | 43 |
| 13.2.18 | General – Behavior after switching on by group object..... | 44 |
| 13.2.19 | General – °C/°F + ECO button control function..... | 44 |
| 13.2.20 | General – Device to be lock / unlock by group object..... | 44 |
| 13.2.21 | General – Temperature display..... | 44 |
| 13.2.22 | General – Temperature display units..... | 45 |
| 13.2.23 | General – Switchover temperature display units via group object | 45 |
| 13.2.24 | General – Status byte device..... | 45 |
| 13.2.25 | General – Request status values..... | 45 |
| 13.2.26 | Application Parameters - Basic-stage heating..... | 45 |
| 13.2.27 | Application Parameters - Additional-stage heating..... | 46 |
| 13.2.28 | Application Parameters - Basic-stage cooling..... | 47 |
| 13.2.29 | Application Parameters - Additional-stage cooling..... | 48 |
| 13.2.30 | Application Parameters - Type of heating/cooling system..... | 48 |
| 13.2.31 | Application Parameters - Heating/Cooling changeover..... | 49 |
| 13.2.32 | Application Parameters - Use 6 way valve..... | 49 |
| 13.2.33 | Application Parameters - Actuate basic-stage heating via..... | 50 |
| 13.2.34 | Application Parameters - Actuate basic-stage cooling via..... | 51 |
| 13.2.35 | Application Parameters - Actuate additional-stage heating via... .. | 51 |
| 13.2.36 | Application Parameters - Actuate additional-stage cooling via | 52 |
| 13.2.37 | Application Parameters - Switch relay output independently of fan speed (including when fan = 0)..... | 53 |
| 13.2.38 | Application Parameters - Automatic reset of manual relay overdrive to controller operation after..... | 54 |

| | | |
|---------|--|----|
| 13.2.39 | Application Parameters - Window status input..... | 54 |
| 13.2.40 | Application Parameters - Window open when | 54 |
| 13.2.41 | Application Parameters - Dew point status input | 55 |
| 13.2.42 | Application Parameters - Dew point reach when | 55 |
| 13.2.43 | Application Parameters - Fill level sensor input | 56 |
| 13.2.44 | Application Parameters - Fill level reached when | 56 |
| 13.2.45 | Application Parameters - Temperature input | 57 |
| 13.2.46 | Application Parameters - Number of temperature input objects.. | 57 |
| 13.2.47 | Application Parameters - Physical device input + Internal measurement weighting | 58 |
| 13.2.48 | Application Parameters - Weighting of external measurement 1 | 58 |
| 13.2.49 | Application Parameters - Weighting of external measurement 2 | 58 |
| 13.2.50 | Application Parameters - Occupancy presence detection logic.. | 59 |
| 13.2.51 | Application Parameters - Occupancy presence detection logic flow chart | 61 |
| 13.2.52 | Application Parameters - To include physical output VB/RO for power energization | 61 |
| 13.2.53 | Fan only mode | 62 |
| 13.2.54 | Application Parameters - Door contact detection..... | 62 |
| 13.2.55 | Application Parameters - Door open when | 62 |
| 13.2.56 | Application Parameters - Duration for first checking of presence | 62 |
| 13.2.57 | Application Parameters - Duration for second checking of presence before activating ECO mode..... | 62 |
| 13.2.58 | Application Parameters - Presence detection | 63 |
| 13.2.59 | Application Parameters - Presence detection when | 63 |
| 13.2.60 | Device Function - Heating/Cooling/Off mode after 230V recovery.. | 63 |
| 13.2.61 | Device Function - Control value after 230V recovery..... | 63 |
| 13.2.62 | Device Function - Control value..... | 63 |
| 13.2.63 | Device Function - Reaction on 230V recovery fan output..... | 64 |
| 13.2.64 | Device Function - Reaction on 230V recovery relay output | 64 |
| 13.2.65 | Device Function - Heating/cooling mode after ETS download/reset | 64 |
| 13.2.66 | Device Function - Control value after ETS download | 64 |
| 13.2.67 | Device Function - Control value..... | 65 |
| 13.2.68 | Device Function - Fan output after ETS download | 65 |
| 13.2.69 | Device Function - Relay output after ETS download | 65 |
| 13.2.70 | Temperature controller | 65 |
| 13.2.71 | Temperature controller – Minimum control value for basic load > 0 | 66 |
| 13.2.72 | Temperature controller – Basic load active when controller off... | 66 |
| 13.2.73 | Temperature controller – Send inactive control values cyclically | 66 |
| 13.2.74 | Temperature controller – Send current room temperature cyclically (0 = cyclical sending deactivated)..... | 67 |
| 13.2.75 | Temperature controller – Temperature change for sending current room temperature | 67 |
| 13.2.76 | Temperature controller – Basic-stage heating control value type | 67 |
| 13.2.77 | Temperature controller – 2-point 1 bit (On/Off), 2-point 1 byte (0/100%) | 69 |
| 13.2.78 | Temperature controller – Use control value for fan automation .. | 69 |
| 13.2.79 | Temperature controller – Extended settings | 69 |
| 13.2.80 | Temperature controller – Control value direction | 69 |
| 13.2.81 | Temperature controller – Hysteresis..... | 70 |

| | | |
|----------|---|----|
| 13.2.82 | Temperature controller – Send control value cyclically (0 = cyclical sending disabled) | 70 |
| 13.2.83 | Temperature controller – Activate temperature limitation | 71 |
| 13.2.84 | Temperature controller – Limited temperature..... | 71 |
| 13.2.85 | Temperature controller – Limit temperature hysteresis..... | 71 |
| 13.2.86 | Temperature controller – Input for temperature limit sensor | 71 |
| 13.2.87 | Temperature controller – PI continuous (0...100 %), PI PWM (On/Off), PI continuous (0...100 %) for Fan Coil | 72 |
| 13.2.88 | Temperature controller – P-proportion..... | 72 |
| 13.2.89 | Temperature controller – I-proportion | 72 |
| 13.2.90 | Temperature controller – Use control value for fan automation .. | 73 |
| 13.2.91 | Temperature controller – Extended settings | 73 |
| 13.2.92 | Temperature controller – Control value direction | 73 |
| 13.2.93 | Temperature controller – Control value difference for sending control value | 73 |
| 13.2.94 | Temperature controller – Send control value cyclically (0 = cyclical sending disabled) | 74 |
| 13.2.95 | Temperature controller – Heating PWM cycle | 74 |
| 13.2.96 | Temperature controller – Max. control value..... | 75 |
| 13.2.97 | Temperature controller – Min. control value (basic load)..... | 75 |
| 13.2.98 | Temperature controller – Activate temperature limitation | 75 |
| 13.2.99 | Temperature controller – Limited temperature..... | 76 |
| 13.2.100 | Temperature controller – Limit temperature hysteresis..... | 76 |
| 13.2.101 | Temperature controller – I-proportion on temperature limitation . | 76 |
| 13.2.102 | Temperature controller – Input for temperature limit sensor | 77 |
| 13.2.103 | Temperature controller – Additional-stage heating | 77 |
| 13.2.104 | Temperature controller – Additional-stage heating control value type | 77 |
| 13.2.105 | Temperature controller – 2-point 1 bit (On/Off), 2-point 1 byte (0/100%) | 79 |
| 13.2.106 | Temperature controller – Temperature difference from basic-stage heating | 79 |
| 13.2.107 | Temperature controller – Use control value for fan automation .. | 79 |
| 13.2.108 | Temperature controller – Extended settings | 80 |
| 13.2.109 | Temperature controller – Control value direction | 80 |
| 13.2.110 | Temperature controller – Hysteresis..... | 80 |
| 13.2.111 | Temperature controller – Send control value cyclically (0 = cyclical sending disabled) | 81 |
| 13.2.112 | Temperature controller – Activate temperature limitation | 81 |
| 13.2.113 | Temperature controller – Limited temperature..... | 81 |
| 13.2.114 | Temperature controller – Limit temperature hysteresis..... | 81 |
| 13.2.115 | Temperature controller – Input for temperature limit sensor | 82 |
| 13.2.116 | Temperature controller – PI continuous (0...100 %), PI PWM (On/Off), PI continuous (0...100 %) for Fan Coil | 82 |
| 13.2.117 | Temperature controller – Temperature difference from basic-stage heating | 82 |
| 13.2.118 | Temperature controller – P-proportion..... | 83 |
| 13.2.119 | Temperature controller – I-proportion | 83 |
| 13.2.120 | Temperature controller – Use control value for fan automation .. | 83 |
| 13.2.121 | Temperature controller – Extended settings | 84 |
| 13.2.122 | Temperature controller – Control value direction | 84 |
| 13.2.123 | Temperature controller – Control value difference for sending control value | 84 |

| | | |
|----------|---|-----|
| 13.2.124 | Temperature controller – Send control value cyclically (0 = cyclical sending disabled) | 85 |
| 13.2.125 | Temperature controller – Heating PWM cycle | 85 |
| 13.2.126 | Temperature controller – Max. control value..... | 86 |
| 13.2.127 | Temperature controller – Min. control value (basic load) | 86 |
| 13.2.128 | Temperature controller – Activate temperature limitation | 86 |
| 13.2.129 | Temperature controller – Limited temperature..... | 87 |
| 13.2.130 | Temperature controller – Limit temperature hysteresis..... | 87 |
| 13.2.131 | Temperature controller – I-proportion on temperature limitation . | 87 |
| 13.2.132 | Temperature controller – Input for temperature limit sensor | 87 |
| 13.2.133 | Temperature controller – Basic-stage cooling..... | 88 |
| 13.2.134 | Temperature controller – Basic-stage cooling control value type | 88 |
| 13.2.135 | Temperature controller – 2-point 1 bit (On/Off), 2-point 1 byte (0/100%) | 89 |
| 13.2.136 | Temperature controller – Use control value for fan automation .. | 89 |
| 13.2.137 | Temperature controller – Extended settings | 90 |
| 13.2.138 | Temperature controller – Control value direction | 90 |
| 13.2.139 | Temperature controller – Hysteresis..... | 90 |
| 13.2.140 | Temperature controller – Send control value cyclically (0 = cyclical sending disabled) | 91 |
| 13.2.141 | Temperature controller – Activate temperature limitation | 91 |
| 13.2.142 | Temperature controller – Limited temperature..... | 91 |
| 13.2.143 | Temperature controller – Limit temperature hysteresis..... | 92 |
| 13.2.144 | Temperature controller – Input for temperature limit sensor | 92 |
| 13.2.145 | Temperature controller – PI continuous (0...100 %), PI PWM (On/Off), PI continuous (0...100 %) for Fan Coil | 92 |
| 13.2.146 | Temperature controller – P-proportion..... | 92 |
| 13.2.147 | Temperature controller – I-proportion | 93 |
| 13.2.148 | Temperature controller – Use control value for fan automation .. | 93 |
| 13.2.149 | Temperature controller – Extended settings | 93 |
| 13.2.150 | Temperature controller – Control value direction | 93 |
| 13.2.151 | Temperature controller – Control value difference for sending control value | 94 |
| 13.2.152 | Temperature controller – Send control value cyclically (0 = cyclical sending disabled) | 94 |
| 13.2.153 | Temperature controller – Cooling PWM cycle..... | 94 |
| 13.2.154 | Temperature controller – Max. control value..... | 95 |
| 13.2.155 | Temperature controller – Min. control value (basic load) | 95 |
| 13.2.156 | Temperature controller – Activate temperature limitation | 96 |
| 13.2.157 | Temperature controller – Limited temperature..... | 96 |
| 13.2.158 | Temperature controller – Limit temperature hysteresis..... | 96 |
| 13.2.159 | Temperature controller – I-proportion on temperature limitation . | 97 |
| 13.2.160 | Temperature controller – Input for temperature limit sensor | 97 |
| 13.2.161 | Temperature controller – Additional-stage cooling..... | 97 |
| 13.2.162 | Temperature controller – Additional-stage cooling control value type | 98 |
| 13.2.163 | Temperature controller – 2-point 1 bit (On/Off), 2-point 1 byte (0/100%) | 99 |
| 13.2.164 | Temperature difference from basic-stage cooling..... | 99 |
| 13.2.165 | Temperature controller – Use control value for fan automation .. | 99 |
| 13.2.166 | Temperature controller – Extended settings | 100 |
| 13.2.167 | Temperature controller – Control value direction | 100 |
| 13.2.168 | Temperature controller – Hysteresis..... | 100 |

| | | |
|----------|---|-----|
| 13.2.169 | Temperature controller – Send control value cyclically (0 = cyclical sending disabled) | 101 |
| 13.2.170 | Temperature controller – Activate temperature limitation | 101 |
| 13.2.171 | Temperature controller – Limited temperature..... | 101 |
| 13.2.172 | Temperature controller – Limit temperature hysteresis..... | 102 |
| 13.2.173 | Temperature controller – Input for temperature limit sensor | 102 |
| 13.2.174 | Temperature controller – PI continuous (0...100 %), PI PWM (On/Off), PI continuous (0...100 %) for Fan Coil | 102 |
| 13.2.175 | Temperature controller – P-proportion..... | 102 |
| 13.2.176 | Temperature controller – I-proportion | 103 |
| 13.2.177 | Temperature controller – Use control value for fan automation | 103 |
| 13.2.178 | Temperature controller – Extended settings | 103 |
| 13.2.179 | Temperature controller – Control value direction | 104 |
| 13.2.180 | Temperature controller – Control value difference for sending control value | 104 |
| 13.2.181 | Temperature controller – Send control value cyclically (0 = cyclical sending disabled) | 104 |
| 13.2.182 | Temperature controller – Cooling PWM cycle..... | 105 |
| 13.2.183 | Temperature controller – Max. control value..... | 105 |
| 13.2.184 | Temperature controller – Min. control value (basic load) | 106 |
| 13.2.185 | Temperature controller – Activate temperature limitation | 106 |
| 13.2.186 | Temperature controller – Limited temperature..... | 106 |
| 13.2.187 | Temperature controller – Limit temperature hysteresis..... | 106 |
| 13.2.188 | Temperature controller – I-proportion on temperature limitation | 107 |
| 13.2.189 | Temperature controller – Input for temperature limit sensor | 107 |
| 13.2.190 | Setpoint manager | 107 |
| 13.2.191 | Setpoint manager - Operating modes..... | 107 |
| 13.2.192 | Operating mode after 230V recovery, ETS download and reset | 108 |
| 13.2.193 | Setpoint manager - Comfort heating setpoint = Comfort cooling setpoint | 108 |
| 13.2.194 | Setpoint manager - Comfort heating setpoint = Comfort cooling setpoint set as NO | 109 |
| 13.2.195 | Setpoint manager - Comfort heating setpoint | 109 |
| 13.2.196 | Setpoint manager - Comfort cooling setpoint..... | 109 |
| 13.2.197 | Setpoint manager - Comfort heating setpoint = Comfort cooling setpoint set as Yes | 110 |
| 13.2.198 | Setpoint manager - Hysteresis for Toggle heating/cooling | 110 |
| 13.2.199 | Setpoint manager - Setpoint for Comfort heating and cooling .. | 110 |
| 13.2.200 | Setpoint manager - Setpoint specification and adjustment..... | 110 |
| 13.2.201 | Setpoint manager - Selection of Setpoint specification and adjustment is Absolute | 111 |
| 13.2.202 | Setpoint manager - Standby heating setpoint..... | 111 |
| 13.2.203 | Setpoint manager - Economy heating setpoint | 111 |
| 13.2.204 | Setpoint manager - Standby cooling setpoint | 111 |
| 13.2.205 | Setpoint manager - Economy cooling setpoint..... | 112 |
| 13.2.206 | Setpoint manager - Selection of Setpoint specification and adjustment is Relative | 112 |
| 13.2.207 | Setpoint manager - Standby heating reduction..... | 112 |
| 13.2.208 | Setpoint manager - Economy heating reduction | 112 |
| 13.2.209 | Setpoint manager - Increase for Standby cooling | 113 |
| 13.2.210 | Setpoint manager – Increase for Economy cooling | 113 |
| 13.2.211 | Setpoint manager - Base setpoint is | 113 |

| | | |
|----------|---|-----|
| 13.2.212 | Setpoint manager - Setpoint for frost protection (building protection, heating)..... | 114 |
| 13.2.213 | Setpoint manager - Heat protection setpoint (building protection, cooling) | 114 |
| 13.2.214 | Setpoint manager - Send current setpoint | 115 |
| 13.2.215 | Setpoint manager - Send current setpoint cyclically | 115 |
| 13.2.216 | Setpoint manager - Summer compensation..... | 115 |
| 13.2.217 | Setpoint manager - (Lower) starting temperature for summer compensation | 115 |
| 13.2.218 | Setpoint manager - Setpoint temperature offset when summer compensation starts | 116 |
| 13.2.219 | Setpoint manager - (Upper) escape temperature for summer compensation | 116 |
| 13.2.220 | Setpoint manager - Setpoint temperature offset when summer compensation ends | 116 |
| 13.2.221 | Monitoring and Safety | 116 |
| 13.2.222 | Monitoring and Safety - Use forced operation..... | 116 |
| 13.2.223 | Monitoring and Safety - Forced operation dependent parameters.. | 117 |
| 13.2.224 | Monitoring and Safety - Control value (Forced operation 1 bit; 1 active & Forced operation 1 bit; 0 active) / Control value for forced operation ON (Forced operation 2 bit) / Control value for forced operation OFF (Forced operation 2 bit)..... | 117 |
| 13.2.225 | Monitoring and Safety - Fan output (Forced operation 1 bit; 1 active & Forced operation 1 bit; 0 active) / Fan output for forced operation ON (Forced operation 2 bit) / Fan output for forced operation OFF (Forced operation 2 bit)..... | 118 |
| 13.2.226 | Monitoring and Safety - Cyclical monitoring..... | 119 |
| 13.2.227 | Monitoring and Safety - Temperature input monitoring | 119 |
| 13.2.228 | Monitoring and Safety - Time interval for cyclical monitoring | 120 |
| 13.2.229 | Monitoring and Safety - Control value after exceeding monitoring time / Control value on input fault | 120 |
| 13.2.230 | Monitoring and Safety - Monitor receipt of group object "Operating mode" | 121 |
| 13.2.231 | Monitoring and Safety - Time interval for cyclical monitoring | 121 |
| 13.2.232 | Monitoring and Safety - Operating mode after exceeding monitoring time | 121 |
| 13.2.233 | Monitoring and Safety - Monitor receipt of group object "Toggle heating/cooling" | 122 |
| 13.2.234 | Monitoring and Safety - Time interval for cyclical monitoring | 122 |
| 13.2.235 | Monitoring and Safety - Heating/cooling mode when monitoring time exceeded | 122 |
| 13.2.236 | Monitoring and Safety - Monitor receipt of group object "Window contact" | 122 |
| 13.2.237 | Monitoring and Safety - Time interval for cyclical monitoring | 123 |
| 13.2.238 | Monitoring and Safety - Monitor receipt of group object "Dew point alarm" | 123 |
| 13.2.239 | Monitoring and Safety - Time interval for cyclical monitoring | 123 |
| 13.2.240 | Monitoring and Safety - Monitor receipt of group object "Fill level alarm" | 124 |
| 13.2.241 | Monitoring and Safety - Time interval for cyclical monitoring | 124 |
| 13.2.242 | Valve A | 124 |
| 13.2.243 | On/Off version - Valve output..... | 124 |

| | | |
|----------|--|-----|
| 13.2.244 | On/Off version - Selection of Motor-driven (3-point) | 125 |
| 13.2.245 | On/Off version - Reversing time | 125 |
| 13.2.246 | On/Off version - Switch on time for valve drive from 0 to 100 % | 125 |
| 13.2.247 | On/Off version - Automatic adjustment of valve drive | 125 |
| 13.2.248 | On/Off version - Number of changes until adjustment | 126 |
| 13.2.249 | On/Off version - Selection of Open/Close signal | 126 |
| 13.2.250 | On/Off version - Valve drive operating principle, de-energized | 126 |
| 13.2.251 | On/Off version - Open if control value greater than or equal to | 127 |
| 13.2.252 | On/Off version - Valve drive opening/closing time | 127 |
| 13.2.253 | On/Off version - Send status values | 127 |
| 13.2.254 | On/Off version - Every | 128 |
| 13.2.255 | On/Off version - Enable manual valve override | 128 |
| 13.2.256 | On/Off version - Valve purge | 128 |
| 13.2.257 | On/Off version - Purge cycle in weeks | 129 |
| 13.2.258 | On/Off version - Send group object "Status Valve purge" | 129 |
| 13.2.259 | On/Off version - Every | 130 |
| 13.2.260 | 0~10V version - Valve output | 130 |
| 13.2.261 | 0~10V version - Voltage range valve control value | 130 |
| 13.2.262 | 0~10V version - 6-way valve type | 131 |
| 13.2.263 | 6-way valve type - Voltage range for cooling | 132 |
| 13.2.264 | 6-way valve type - Voltage for maximum cooling | 132 |
| 13.2.265 | 6-way valve type - Voltage for minimum cooling/cooling valve closed | 132 |
| 13.2.266 | 6-way valve type - Voltage for minimum heating/heating valve closed | 132 |
| 13.2.267 | 6-way valve type - Voltage for maximum heating | 133 |
| 13.2.268 | 6-way valve type - Valve drive opening/closing time | 133 |
| 13.2.269 | 0~10V version - Voltage range VAV damper control value | 133 |
| 13.2.270 | 0~10V version - Send status values | 133 |
| 13.2.271 | 0~10V version - Every | 134 |
| 13.2.272 | 0~10V version - Enable manual valve override | 134 |
| 13.2.273 | 0~10V version - Valve purge | 134 |
| 13.2.274 | 0~10V version - Purge cycle in weeks | 135 |
| 13.2.275 | 0~10V version - Reset purge cycle from control value greater than or equal to | 135 |
| 13.2.276 | 0~10V version - Send group object "Status Valve purge" | 136 |
| 13.2.277 | 0~10V version - Every | 136 |
| 13.2.278 | VAV damper - Reaction on 230V recovery, ETS download and ETS reset | 136 |
| 13.2.279 | VAV damper - Control value | 136 |
| 13.2.280 | VAV damper - Send status values | 137 |
| 13.2.281 | VAV damper - Every | 137 |
| 13.2.282 | Valve B | 137 |
| 13.2.283 | Fan output | 137 |
| 13.2.284 | Fan output - Number of fan speeds | 137 |
| 13.2.285 | Fan output - Fan type of operation (important: observe the technical data for the fan) | 138 |
| 13.2.286 | Fan output - Delay between fan speed switchover | 138 |
| 13.2.287 | Fan output - Enable automatic mode based on control value | 138 |
| 13.2.288 | Fan output - Threshold value speed 0 <-> 1 | 139 |
| 13.2.289 | Fan output - Threshold value speed 1 <-> 2 | 139 |
| 13.2.290 | Fan output - Threshold value speed 2 <-> 3 | 139 |
| 13.2.291 | Fan output - Threshold values hysteresis | 139 |

| | | |
|----------|---|-----|
| 13.2.292 | Fan output - Minimum holding time at fan speed | 141 |
| 13.2.293 | Fan output - Return from manual fan adjustment to automatic mode | 141 |
| 13.2.294 | Fan output - Reset time | 141 |
| 13.2.295 | Fan output - Enable start-up behavior (switch on from Off to On)..... | 141 |
| 13.2.296 | Fan output - Switch on at fan speed | 142 |
| 13.2.297 | Fan output - Minimum holding time at switch on speed | 142 |
| 13.2.298 | Fan output - Enable run-on behavior for fan speed reduction... | 142 |
| 13.2.299 | Fan output - Run-on speed 1 | 142 |
| 13.2.300 | Fan output - Run-on speed 2 | 142 |
| 13.2.301 | Fan output - Run-on speed 3 | 143 |
| 13.2.302 | Fan output - Fan speed limitation | 143 |
| 13.2.303 | Fan output - Limitation 1, Limitation 2, Limitation 3 have the same parameter | 143 |
| 13.2.304 | Fan output - Switch fan speed via 1-bit objects | 144 |
| 13.2.305 | Fan output - Send status values | 145 |
| 13.2.306 | Fan output - Every | 146 |
| 13.2.307 | Electric heater relay output | 146 |
| 13.2.308 | Electric heater relay output - Electric heater output is..... | 146 |
| 13.2.309 | Electric heater relay output - Electric heater relay output | 146 |
| 13.2.310 | Electric heater relay output - Electric heater output is..... | 146 |
| 13.2.311 | Electric heater relay output - Electric heater output reaction.... | 147 |
| 13.2.312 | Electric heater relay output - Object value status relay | 147 |
| 13.2.313 | Electric heater relay output - Send status values..... | 147 |
| 13.2.314 | Electric heater relay output - Every..... | 148 |
| 13.2.315 | Setpoint adjustment | 148 |
| 13.2.316 | Setpoint adjustment - Max. manual increase in heating mode via KNX | 148 |
| 13.2.317 | Setpoint adjustment - Max. manual decrease in heating mode via KNX | 148 |
| 13.2.318 | Setpoint adjustment - Max. manual increase in cooling mode via KNX | 148 |
| 13.2.319 | Setpoint adjustment - Max. manual decrease in cooling mode via KNX | 148 |
| 13.2.320 | Setpoint adjustment - Manual setpoint adjustment via KNX with | 149 |
| 13.2.321 | Setpoint adjustment - Manual fan adjustment via KNX with | 149 |
| 13.2.322 | Setpoint adjustment - Reset manual adjustment via KNX when base setpoint received..... | 150 |
| 13.2.323 | Setpoint adjustment - Reset manual adjustment via KNX when operating mode changes | 150 |
| 13.2.324 | Setpoint adjustment - Reset manual adjustment via KNX using group object..... | 150 |
| 13.2.325 | Setpoint adjustment - Slave display indicates..... | 151 |
| 13.2.326 | Input a, Input b..... | 151 |
| 13.2.327 | Input..... | 151 |
| 13.2.328 | Window contact | 151 |
| 13.2.329 | Window contact - Window open when | 152 |
| 13.2.330 | Window contact - Send status value..... | 152 |
| 13.2.331 | Window contact - Send input status cyclically..... | 152 |
| 13.2.332 | Dew point sensor | 152 |
| 13.2.333 | Dew point sensor - Dew point reached when..... | 152 |

| | | |
|----------|---|-----|
| 13.2.334 | Dew point sensor - Send status value | 153 |
| 13.2.335 | Dew point sensor - Send input status cyclically | 153 |
| 13.2.336 | Fill level sensor | 153 |
| 13.2.337 | Fill level sensor - Fill level reached when..... | 153 |
| 13.2.338 | Fill level sensor - Send status value | 153 |
| 13.2.339 | Fill level sensor - Send input status cyclically | 153 |
| 13.2.340 | Temperature sensor | 154 |
| 13.2.341 | Temperature sensor - Temperature sensor type | 154 |
| 13.2.342 | Temperature sensor - NTC type | 154 |
| 13.2.343 | Temperature sensor - Temperature offset | 154 |
| 13.2.344 | Temperature sensor - Cable error compensation | 155 |
| 13.2.345 | Temperature sensor - Cable length, Single distance | 155 |
| 13.2.346 | Temperature sensor - Cross-section of conductor, Value* 0.01 mm ² | 155 |
| 13.2.347 | Temperature sensor - Cable resistance [total of fwd. ret. conductor (ohms)]..... | 155 |
| 13.2.348 | Temperature sensor - Filter | 155 |
| 13.2.349 | Temperature sensor - Send temperature value | 156 |
| 13.2.350 | Temperature sensor - Value is sent from a change of | 156 |
| 13.2.351 | Temperature sensor - Every | 156 |
| 13.2.352 | Binary signal input | 157 |
| 13.2.353 | Binary signal input - Distinction between long and short operation. | 157 |
| 13.2.354 | Binary signal input - Activate minimum signal duration | 157 |
| 13.2.355 | Binary signal input - When contact opens..... | 157 |
| 13.2.356 | Binary signal input - When closing the contact | 158 |
| 13.2.357 | Binary signal input - Input on operation | 158 |
| 13.2.358 | Binary signal input - Long operation after | 158 |
| 13.2.359 | Binary signal input - 1-bit group object "Disable input a"..... | 158 |
| 13.2.360 | Binary signal input - Reaction on event 0, Reaction on event 1 | 158 |
| 13.2.361 | Binary signal input - Internal connection | 159 |
| 13.2.362 | Binary signal input - Send status value..... | 159 |
| 13.2.363 | Binary signal input - Telegram is repeated every | 159 |
| 13.2.364 | Binary signal input - On object value | 160 |
| 13.2.365 | Binary signal input - Scan input after download, ETS reset and 230V recovery | 160 |
| 13.2.366 | Occupancy presence detection logic | 160 |
| 13.2.367 | Occupancy presence detection logic - Door open when..... | 160 |
| 13.2.368 | Occupancy presence detection logic - Send status value..... | 160 |
| 13.2.369 | Occupancy presence detection logic - Send input status cyclically | 161 |
| 13.2.370 | Occupancy presence detection logic - Presence detection..... | 161 |
| 13.2.371 | Occupancy presence detection logic - Send status value..... | 161 |
| 13.2.372 | Occupancy presence detection logic - Send input status cyclically | 161 |
| 13.2.373 | Internal Temperature sensor..... | 161 |
| 13.2.374 | Internal temperature sensor - Input..... | 161 |
| 13.2.375 | Internal temperature sensor - Temperature sensor type..... | 161 |
| 13.2.376 | Internal temperature sensor - NTC type..... | 161 |
| 13.2.377 | Internal temperature sensor - Temperature offset | 161 |
| 13.2.378 | Internal temperature sensor - Filter..... | 162 |
| 13.2.379 | Internal temperature sensor - Send temperature value | 162 |
| 13.2.380 | Internal temperature sensor - Value is sent from a change of .. | 162 |

| | | |
|----------|--|-----|
| 13.2.381 | Internal temperature sensor - Every | 163 |
| 13.3 | Group Objects..... | 163 |
| 14 | Information about planning and application | 178 |
| 14.1 | Room climate control | 178 |

1 Information on the manual

1.1 General information

Please read this manual through carefully and adhere to the information listed. This will ensure reliable operation and long service life of your product. For reasons of clarification, this manual does not contain all the detailed information on all the models of the product, nor can it be taken into consideration all conceivable circumstances related to installation, operation and maintenance.

If additional information is required or problems arise that are not dealt with in this manual, the necessary information can be requested from the manufacturer. The product has been manufactured according to the latest valid regulations governing technology and is operationally reliable. It has been tested and left the factory in a technically safe and reliable state.

To maintain this state for the period of its operation, the specifications of this manual must be observed and adhered to. Modifications and repairs to the product must only be undertaken if the manual expressly permits this. It is only the adherence to the safety instructions and all safety and warning symbols in this manual that will ensure the optimum protection of the user and the environment as well as the safe and trouble-free operation of the product.

1.2 Structure of the manual

This manual provides you with the detailed technical information on the device, its installation and programming. The use of the device is explained by means of examples.

- The chapters "Information on the manual", "Safety" and "Environment" contain general specifications and basic information as well as a description of functions.
- Chapters "Function", "Technical data" and "Circuit diagrams and dimensional drawings" explain the device instrumentation.
- Chapter "Installation and electrical connection" describes the installation, mounting and the electrical connections.
- Chapters "Commissioning" and "Operation" contain instructions on commissioning and how to operate the device.
- One or several chapters "Application ..." contain general information on the individual applications of the device, the setting options of all device parameters and a list of all objects.

1.3 Legal disclaimer

We reserve the right to make technical changes or modify the contents of this document without prior notice. The agreed properties are definitive for any orders placed. ABB does not accept any responsibility whatsoever for potential errors or possible lack of information in this document. We reserve all rights in this document and in the subject matter and illustrations contained therein. Reproduction, transfer to third parties or processing of the content – including sections thereof – is not permitted without prior expressed written permission from ABB. Copyright© 2019 ABB. All rights reserved

1.4 Symbol of the manual



Danger-danger to life

This symbol in connection with the signal word “Danger” indicates dangerous situations which could lead to immediate death or to serious injury.



Warning-danger to life

This symbol in connection with the signal word “Warning” indicates dangerous situations which could lead to immediate death or to serious injury.



Caution-risk to injury

This symbol in connection with the signal word “Caution” indicates a possibly dangerous situations which could lead to slight or moderately serious injury.



Attention-damage to property

This symbol indicates a possibly harmful situation. Non-observance of the safety instructions can lead to damage or destruction of the product.



NOTE

This symbol indicates information or references to addition useful topics. This is not a signal word for a dangerous situation.



This symbol refers to integrated video with addition information on the respective chapter. An Acrobat Reader from Version 9.0 is required to view the videos.



This symbol indicates information on the protection of the environment.

Examples on application, installation and programming are displayed with a grey background.

2 Safety

2.1 Intended use

The device must only be operated within the specified technical data!

Extensive functions are available for the Room Temperature Controller. The scope of applications is contained in chapter "Application ... " (only in languages of the countries EN). RTC can function as standalone or with the integrated bus coupler makes possible the connection to a KNX bus line.



Note: They may only be installed in dry interior rooms in flush-mounted sockets according to BS 4662:2006+A1:2009.

2.2 Improper use

The device represents a danger if it is improperly used. Each non-intended use is deemed improper use. The manufacturer is not liable for damages resulting from such improper use. The associated risk is borne by the user/operator.

The device must never be use outdoors or in bathroom areas. Do not push objects through the openings in the device. The device has an integrated bus coupler. The use of an additional bus coupler is therefore not admissible.

2.3 Target groups and qualifications

Installation, commissioning and maintenance of the product must only be carried out by trained and properly qualified electrical installers. The electrical installers must have read and understood the manual and follow the instructions provided. The operator must adhere to the valid national regulations in his country governing the installation, functional test, repair and maintenance of electrical products.

2.4 Liability and warranty

Improper use, non-observance of this manual, the use of inadequately qualified personnel, as well as unauthorized modification excludes the liability of the manufacturer for the damages caused. It voids the warranty of the manufacturer.

3 Environment



Consider the protection of the environment!

Used electric and electronic devices must not be disposed of with domestic waste.

– The device contains valuable raw materials which can be recycled.
Therefore, dispose of the device at the appropriate collecting depot

All packaging materials and devices bear the markings and test seals for proper disposal. Always dispose of the packaging material and electric devices and their components via the authorized collecting depots and disposal companies.

The products meet the legal requirements, in particular the laws governing electronic and electrical devices and the REACH ordinance.

(EU Directive 2002/96/EC WEEE and 2002/95/EC RoHS)

(EU REACH ordinance and law for the implementation of the ordinance (EC) No.1907/2006)

4 Function

4.1 Fan coil unit overview

Configuration design types

A fan coil unit can be configured as a compact device or a modular installation device:

- Compact devices: These are supplied with enclosures and are available as self-contained units or for wall or ceiling mounting.
- Built-in devices: These have no enclosures and are mounted on the wall, in the ceiling or on the floor. The air is blown into the room through a grille.

Air supply

Fan coil units are available as recirculation or as mixed air devices.

- Recirculation devices: The room air is directed past heat exchangers by the fans.
- Mixed air devices: The room air is mixed with fresh air. The mixing ratio between recirculated and fresh air can usually be adjusted.

4.2 Functional overview

Fans also called blower convectors and fan coil units, are used for distributed heating and cooling applications. They are installed in rooms and powered via central heating and cooling systems. Using fans, room temperature can be quickly adjusted to suit individual preferences.

Caldion room temperature controller control fans either as a single-phase fan with up to three fan speeds via step or changeover actuation. For speed-controlled fans in changeover operation mode, to ensure that no two fan speeds can be switched on simultaneously. An additional programmable switch-over delay is provided for this purpose. Three-phase drives are not supported.

Two inputs are available for connecting temperature sensors and for monitoring a window contact, condensate formation or a collection pan. The scanning voltage for the inputs is provided by the Caldion® room temperature controller. An electric heater can be actuated via output channels (VB/RO) 5(2)A, combine with an external relay due to output channel max output loading In addition to the distinction in the type of fan actuation (3-speed or continuous), the Caldion room temperature have two version in the type of valve actuation.

| Article code | CAR/U4.1.1.1-xx | CAR/U4.2.1.1-xx |
|--|-----------------|-----------------|
| Binary sensor (e.g. window contact, dew point, fill level) | 2 numbers | 2 numbers |
| Temperature sensor | 1 number | 1 number |
| Fan output | Yes | Yes |
| 3 speed fans | 1 number | 1 number |
| 2 speed fans | 1 number | 1 number |
| 1 speed fan | 1 number | 1 number |
| On/Off valve control | 2 numbers | - |
| 0~10V output control | - | 2 numbers |

| | | |
|----------------|----------|----------|
| KNX connection | 1 number | 1 number |
|----------------|----------|----------|

4.3 Input function

For On/Off and 0~10V version

| | Input a | Input b |
|----------------------------------|---------|---------|
| Binary signal input (floating) | X | X |
| Temperature sensor NTC10K | X | X |
| Dew point sensor (floating) | X | X |
| Fill level sensor (floating) | X | X |
| Window contact sensor (floating) | X | X |

4.4 Output function

For On/Off version CAR/U4.1.1.1-xx

| | VA | VB/RO |
|---|------|-------|
| AC 230 V operating voltage (Open/Close) | X | X |
| AC 230 V operating voltage (3-point) | Open | Close |
| Electric heater | - | X |

For 0~10V version CAR/U4.2.1.1-xx

| | 0~10VA | 0~10VB | RO |
|-----------------------------------|--------|--------|----|
| Analog valve drive | | | |
| 0~10V | X | X | - |
| 1~10V | X | X | - |
| 2~10V | X | X | - |
| 10~0V | X | X | - |
| 6-way valve drive | X | - | - |
| VAV Damper drive – control signal | X | X | - |
| Electric heater | - | - | X |

5 Overview of devices

5.1 Front – Picture of product

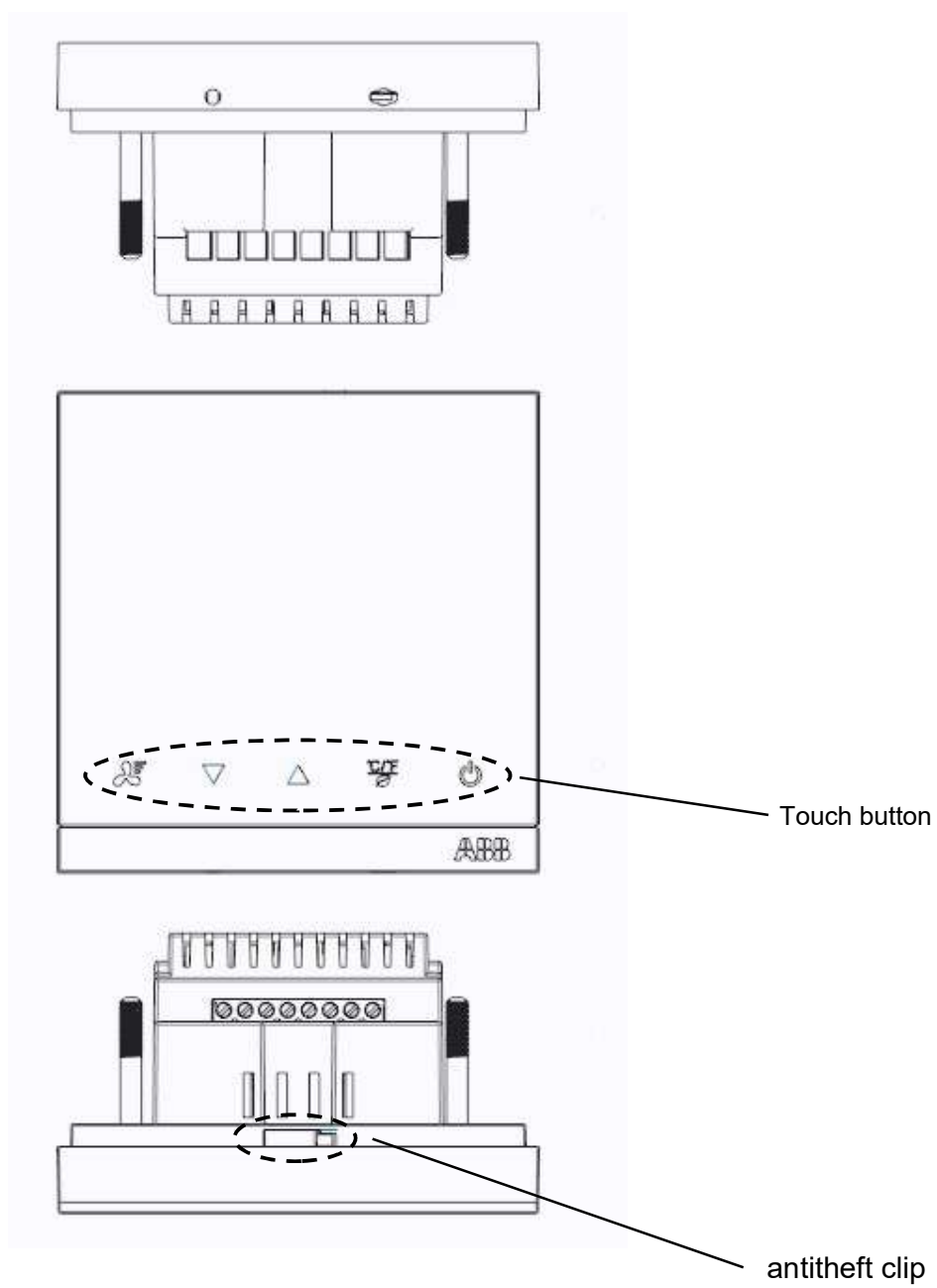

5.2 Rear – Picture of product

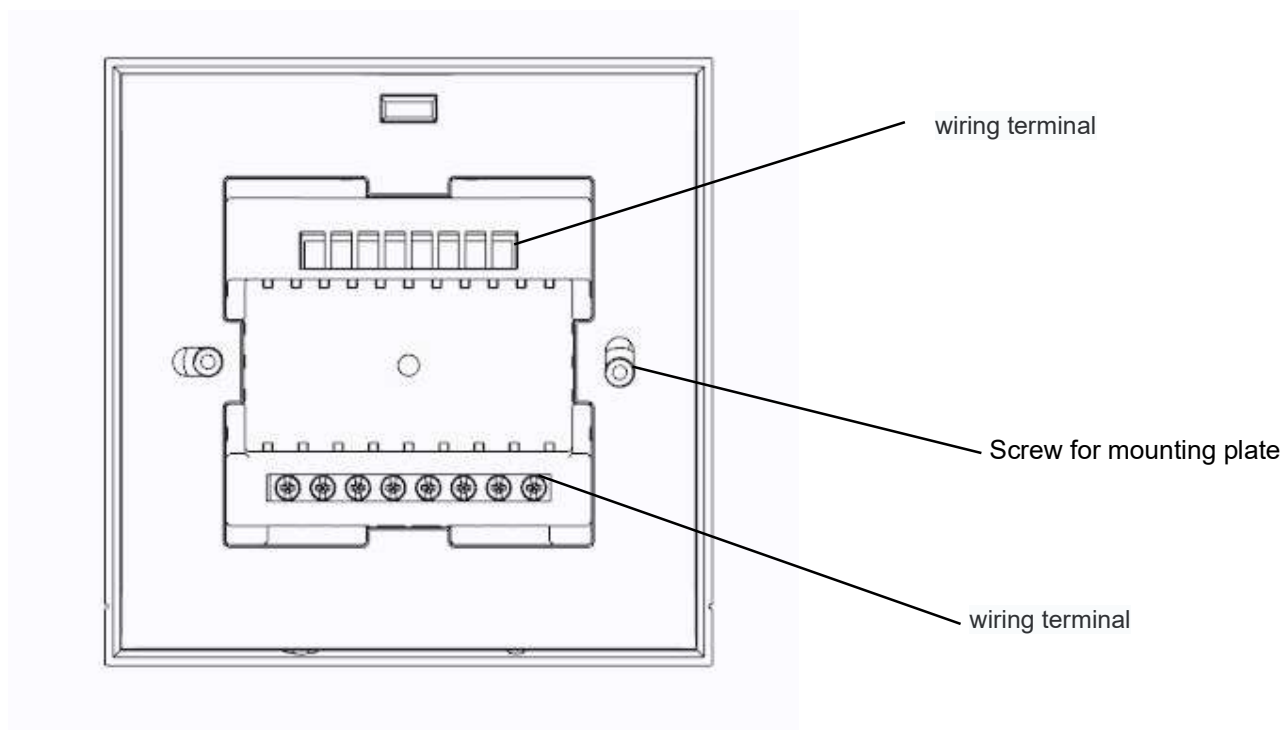

5.3 Bottom – Picture of product

Location of programming button and temperature sensor

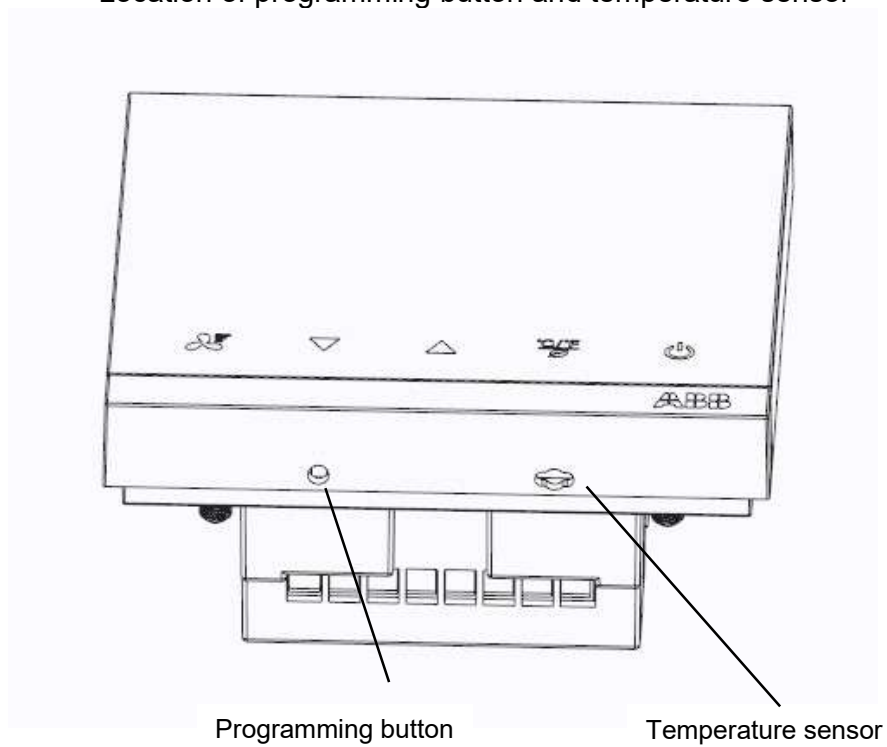

6 Technical data

Control element

| | | |
|--------------------------------|---|--|
| AC power supply | Rate voltage | AC 230 V (min. AC 110 V), 50/60 Hz |
| | Power consumption | Max. 3VA |
| | Maximum allowable input load | Current through phase input (L) terminal Max. 7 A (Fan + Valve + Electric Auxiliary Heating) |
| KNX supply | KNX bus voltage | 21...31 V DC |
| | Current consumption via bus | < 12 mA |
| | Power consumption via bus | Maximum 250 mW |
| Wiring | Wiring cross section on L, N, F1, F2, F3, VA, VB | 1 x 0.5...2.5 mm ² Ø |
| | Wiring cross section on COM, E1, E2, 0~10VA, 0~10VB, KNX+, KNX- | 1 x 0.5...1.5 mm ² Ø |
| Outputs | Control output on F1 / F2 / F3 / VA / VB / RO | AC 230 V / Min. 8.3 mA, Max. 5(2) A; [Resistive (Inductive)] |
| | Max. total load current through terminal "L" (Fx + Vxx) | Max. 7 A |
| | Control output on 0~10VA / 0~10VB | SELV DC 0...10 V; 1.5 mA (Max) (Load resistance shall > 10 KΩ) |
| Inputs | NTC/Binary Input on E1 / E2 | 10V/1mA |
| | Input cable length | Maximum 30 m |
| Operating and display elements | Programming button/LED | For assignment of the physical address |
| Electrical | Endurance | To IEC 60669-2-5 |
| Degree of protection | IP 20 | To EN 60529 |
| Protection class | II | To EN 60730-1 |
| Isolation category | Overvoltage category III | To EN 60664-1 |
| Pollution degree | 2 | To EN 60664-1 |
| Temperature range | Operation | - 5 °C...+50 °C |
| | Storage | -25 °C...+55 °C |
| | Transport | -25 °C...+70 °C |
| Ambient conditions | Maximum air humidity | 95 %, no condensation allowed |
| | Maximum air pressure | Equivalent to 2000 m altitude |
| Mounting type | | BS standard |
| Mounting depth in mm | | Min 40mm depth box |
| Mounting position | | Vertical |
| Dimensions | | 86mmL x 86mmW x 16mmD |
| Housing/color | | Plastic housing/ Black & White |
| Weight | in kg | 0.25 |
| Approvals | Certification | KNX acc. to EN 50090-1, -2 |

| | |
|---------|--|
| CE mark | In accordance with the EMC guideline and low voltage guideline |
|---------|--|



No internal fuse, use max. C 10 A circuit breaker for external protection

For Standalone version

| | | |
|--------|-------------|--|
| Inputs | Input on E1 | Window contact |
| | Input on E2 | NTC10-01:10K (B-Constant at 50°C=3936~3976) |

7 Circuit diagrams and dimensional drawings

7.1 2 pipes on/off

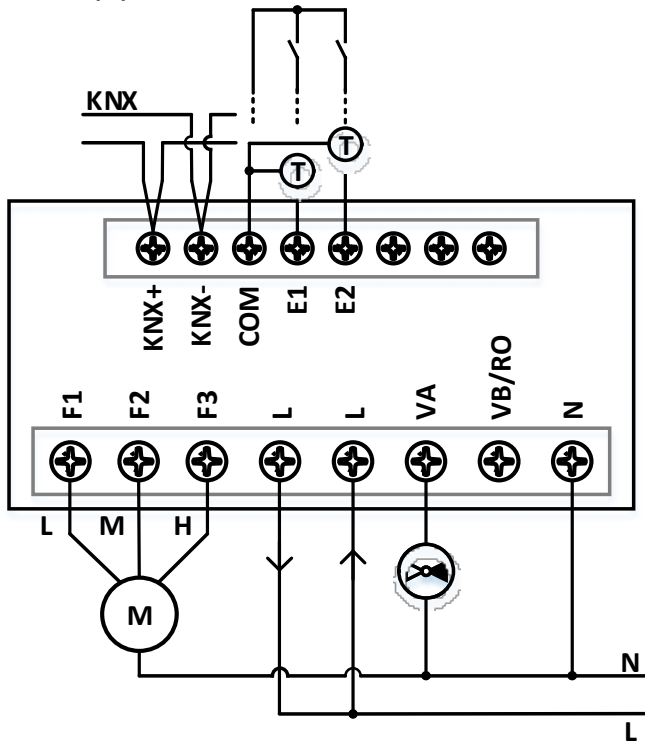

7.2 2 pipes on/off with electrical heater

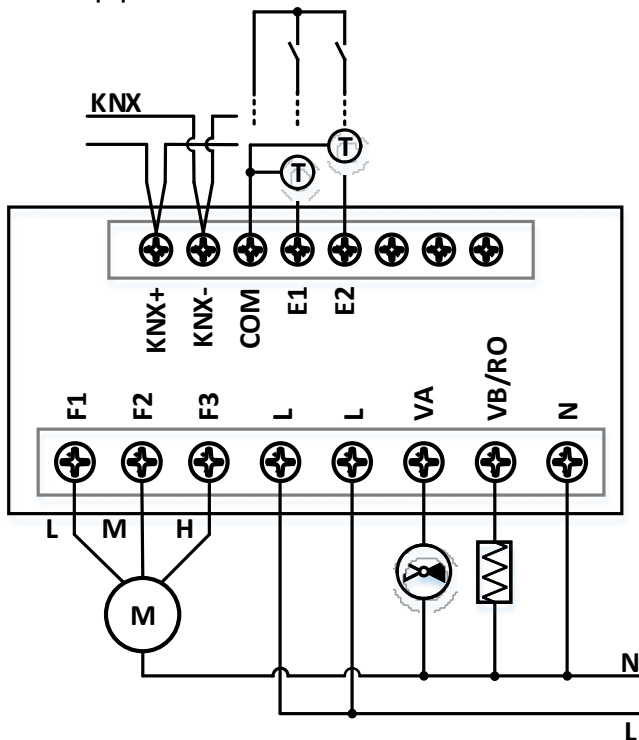

7.3 2 pipes on/off 3 point

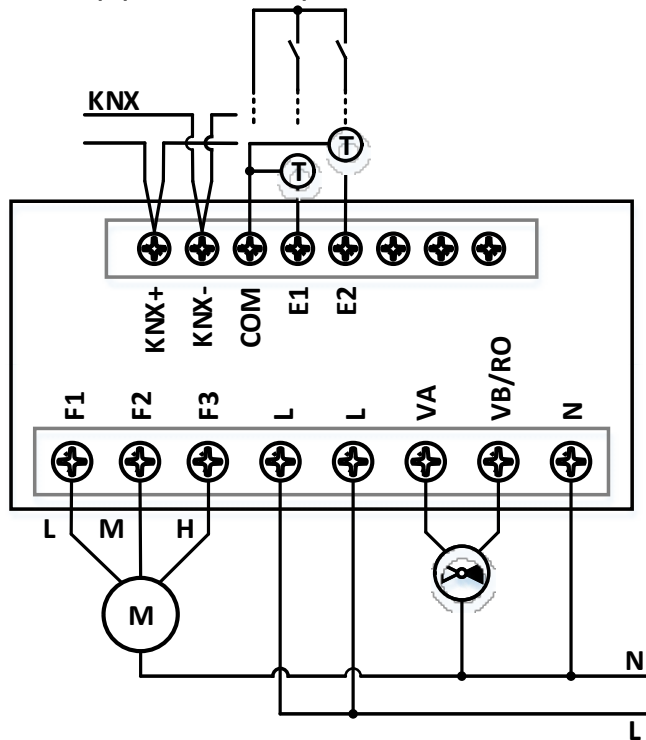

7.4 4 pipes on/off

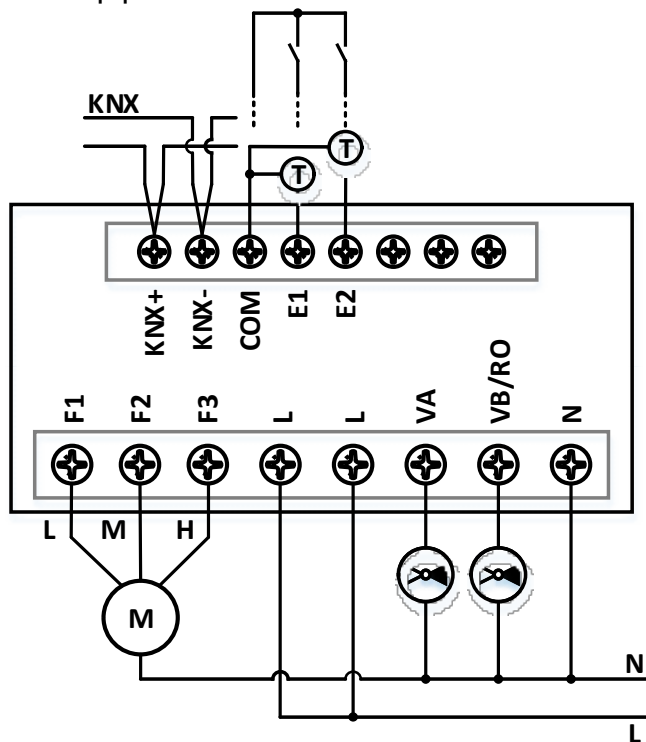

7.5 2 pipes 0~10V

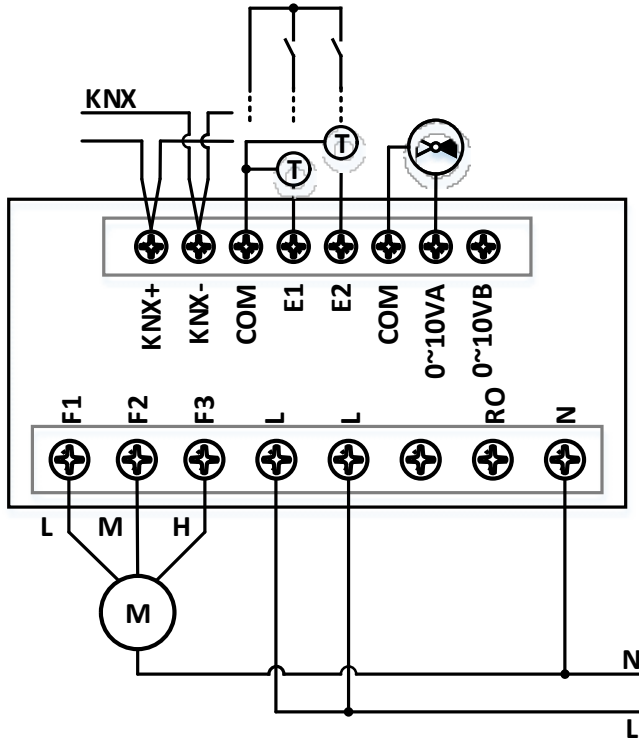

7.6 2 pipe 0~10V with electrical heater

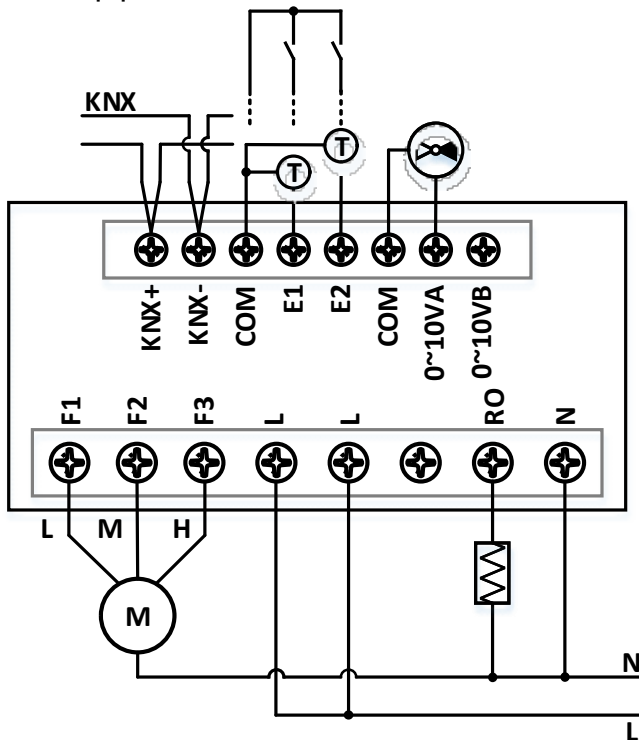

7.7 4 pipes 0~10V

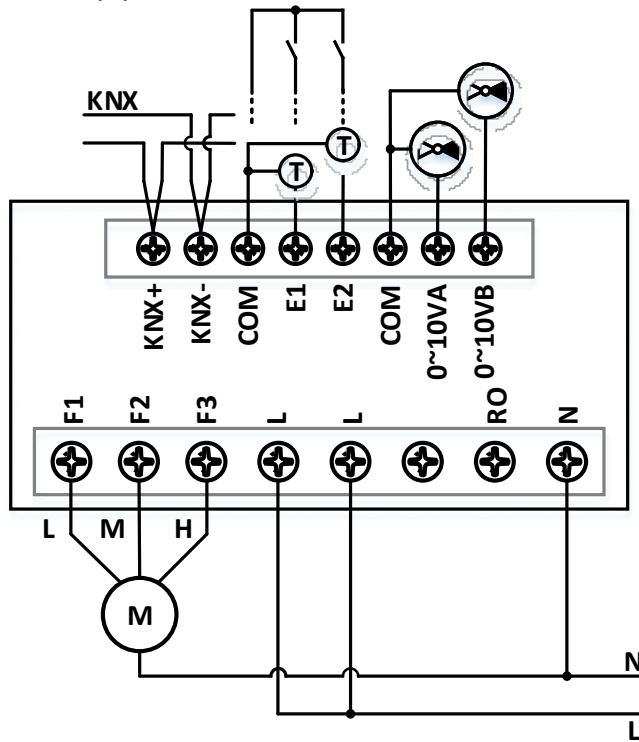

7.8 Dimensional drawing:

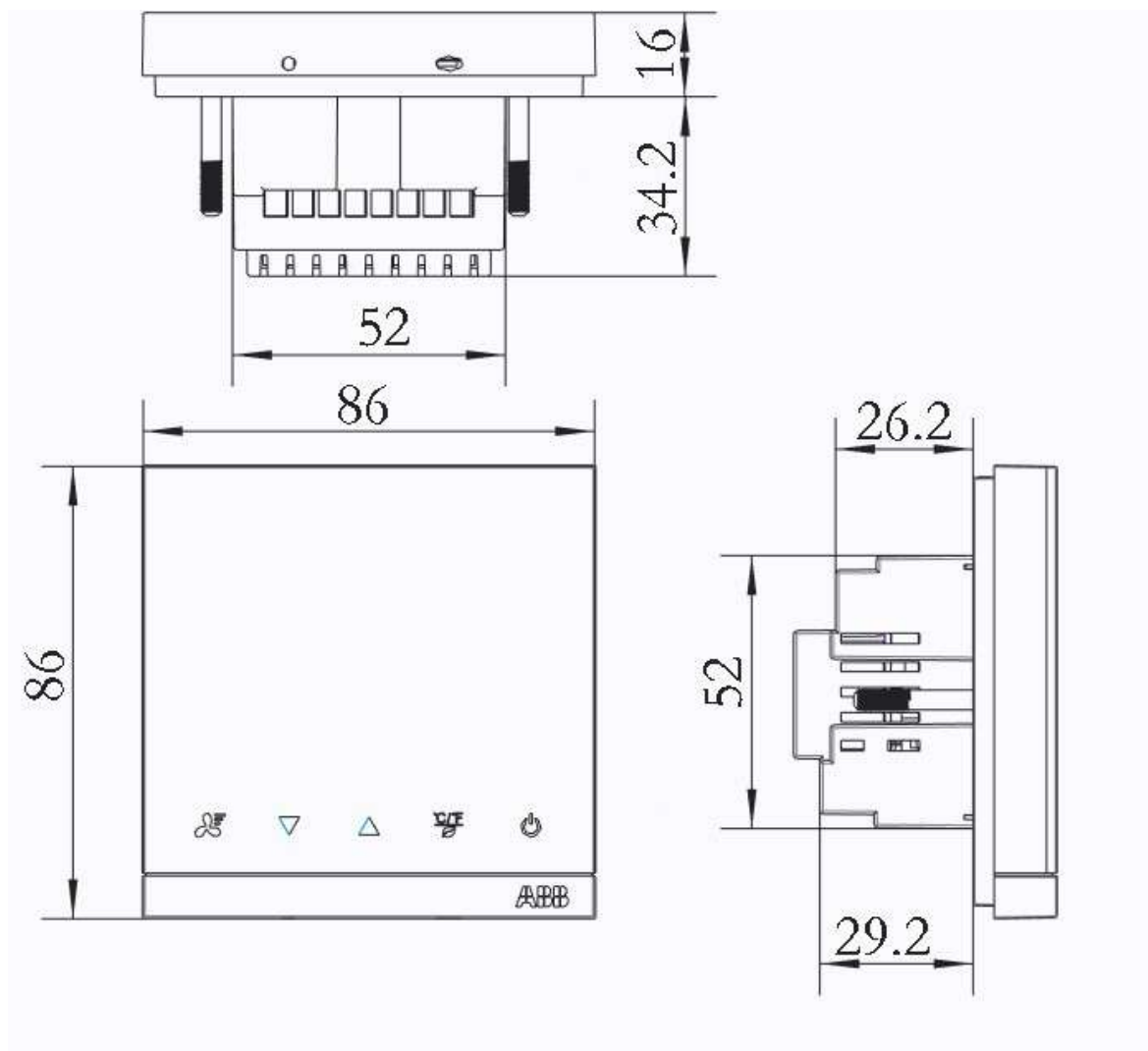

8 Installation and electrical connection



Warning

Electric voltage!

Risk of death due to electrical voltage of 230 V during short-circuit in the low-voltage line.

– Low-voltage and 230 V lines must not be installed together in a flush-mounted socket!

8.1 Requirements for the electricians



Warning

Electric voltage!

Install the device only if you have the necessary electrical engineering knowledge and experience.

- No internal line protection for supply lines to external consumers (F1, F2, F3, VA and VB/RO)
- Risk of fire and injury due to short-circuits
- The 230Vac mains supply line must be equipped with an external circuit breaker which the rated current shall not more than 10A
- Use properly cable size connect to the thermostat, fan and valve actuators for AC 230
- Adapt the line diameters as per local regulations to the rated value of the installed overcurrent protection device
- Use only fan and valve actuators rated AC 230V
- Incorrect installation endangers your life and that of the user of the electrical system.
- Incorrect installation can cause serious damage to property, e.g. due to fire.

The minimum necessary expert knowledge and requirements for the installation are as follows:

- Apply the "five safety rules" (DIN VDE 0105, EN 50110):

1. Disconnect from power;
2. Secure against being re-connected;
3. Ensure there is no voltage;
4. Connect to earth and short-circuit;
5. Cover or barricade adjacent live parts.

- Use suitable personal protective clothing.
- Use only suitable tools and measuring devices.
- Check the supply network type (TN system, IT system, TT system) to secure the following power supply conditions (classic connection to ground, protective earthing, necessary additional measures, etc.).

8.2 Mounting

8.2.1 Installation consideration



Note: BS4662, BS standard flush-mounted box have to be used for mounting of the device.

Caldion room temperature controller are flushed mounted device with an integrated bus coupler. The device with RTC function operates with 230VAC supply voltage.

Selection of a suitable installation location for the controller and suitable parameter settings are essential for good temperature and proximity detection.

- The room temperature controller should be installed approximately 150 cm above the floor and 50 cm from the door frame.

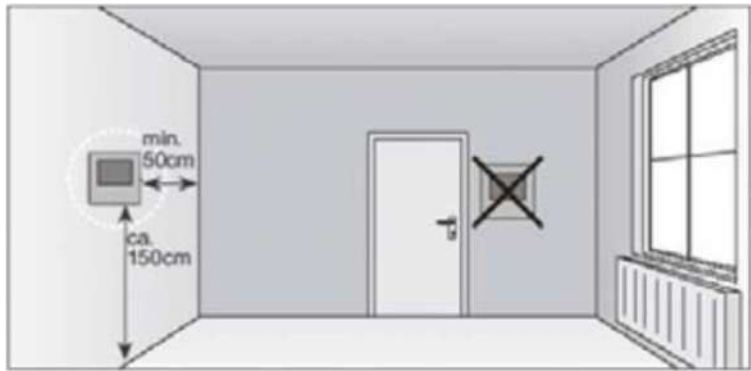

- The room temperature controller should be installed on a wall opposite the radiator.

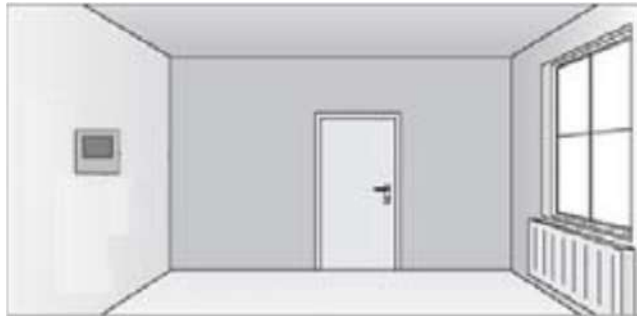

- The radiator and the room temperature controller must not be separated by corners in the room.

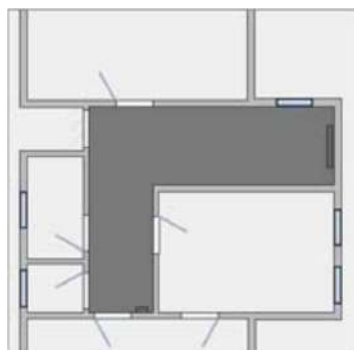

- The room temperature controller should not be installed near a radiator or behind curtains.

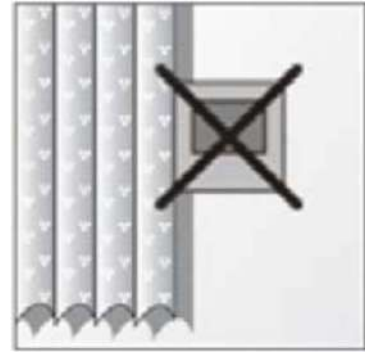
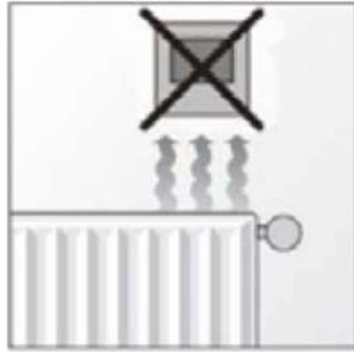

- The room temperature controller should also not be installed on an exterior wall - low outside temperatures will influence the temperature regulation.

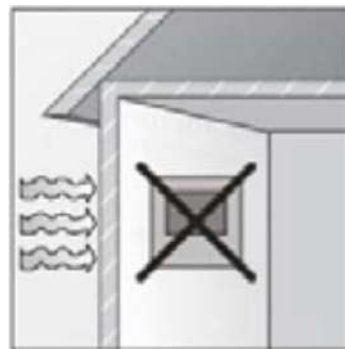

- The room temperature controller must not be exposed to direct contact with liquids.

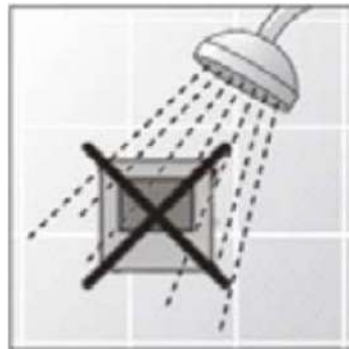

- Temperature regulation will also be affected by exposure to heat from electrical appliances and direct sunlight on the ambient temperature controller.

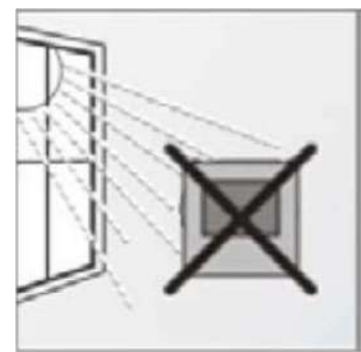
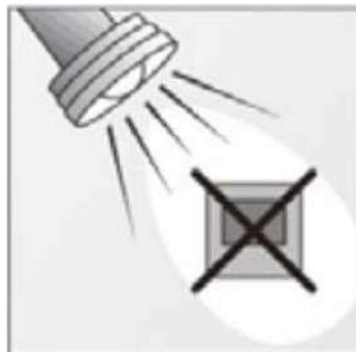

8.2.2 Installation of the device

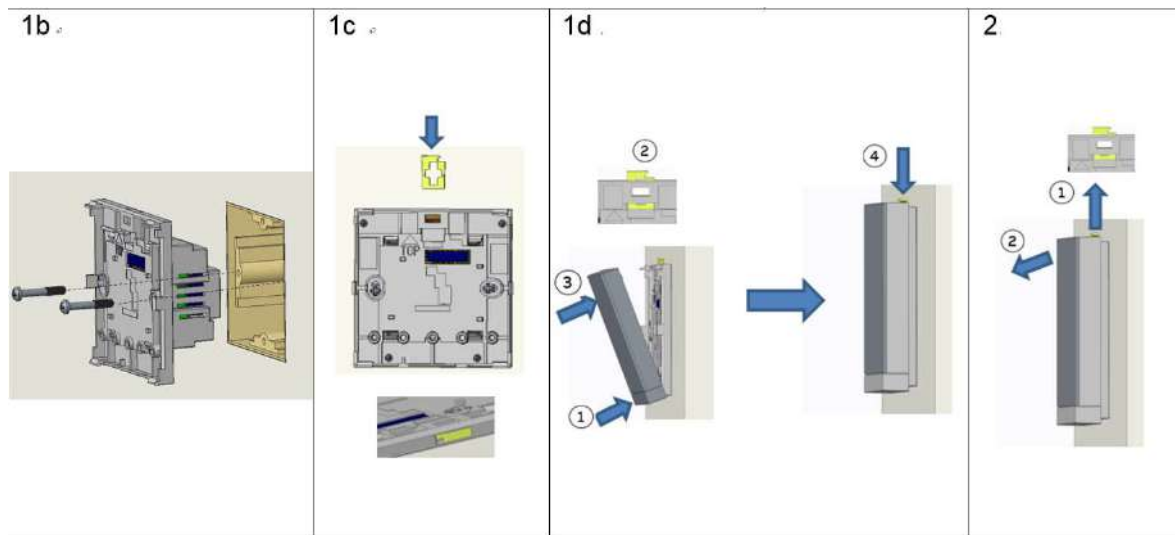

Device may only be installed in dry interior rooms in a flush mounted box. Observe the currently valid regulations.

[1a] Taking reference from wiring diagram for connection. For standalone application (note: KNX bus line is not required)

[1b] Place the base unit on the flush mounted installation box and using the screw to secure the base unit (note: BS standard and 86 standard screw size are different. Flush mounted installation box requires a minimum depth of $\geq 40\text{mm}$. Base unit installation orientation is to follow the “TOP” indication)

[1c] Insert the antitheft clip into the allocated slot (note: clip must be in the correct orientation else it cannot be fully inserted)

[1d] Completion installation with the front cover:

[1d-1] Secure the front cover starting from the bottom

[1d-2] Adjust the antitheft clip to the correct position to allow the installation of front cover top

[1d-3] Push the top of the front cover into position

[1d-4] Once the front cover is in position, push down the antitheft clip all the way down to secure

[2] To remove, follow the procedure in the opposite direction starting from 1d



• Isolate the SELV cables of inputs & outputs E1-COM, E2-COM / 0~10VA-COM, 0~10VB-COM if the conduit box carries AC 230 V mains voltage.



- Use shielded cables for E1-COM, E2-COM / 0~10VA-COM, 0~10VB-COM if these cables are deployed all the way along with AC 230 V mains load line.



- Disconnect from power supply before opening the cover.

8.4 Topology illustration

8.4.1 KNX network topology illustration

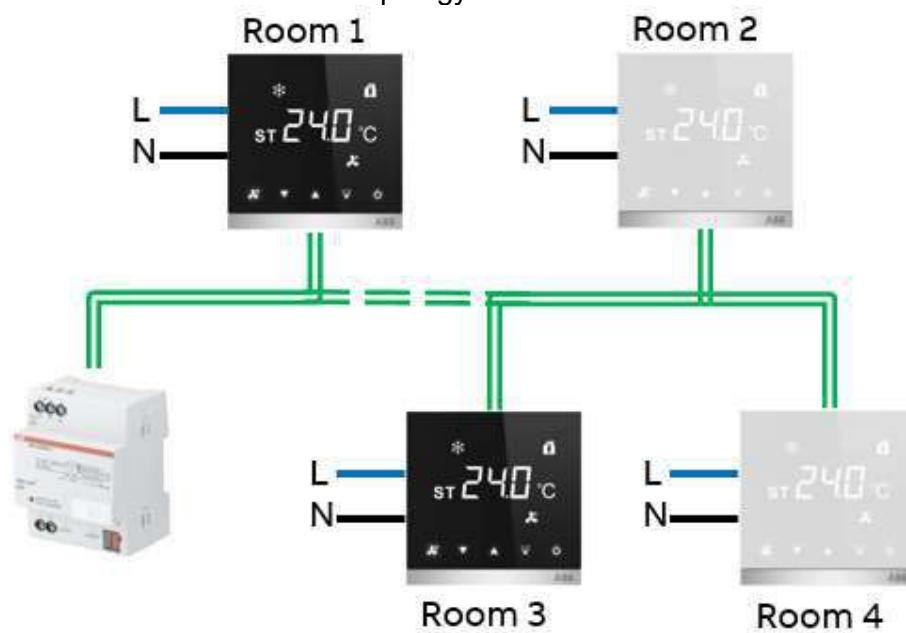

8.4.2 Standalone topology illustration

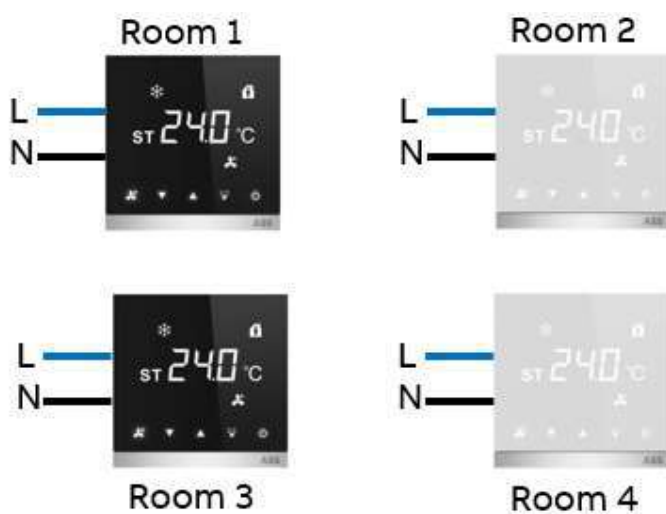

9 Commissioning

| DIP switch | 1 | 2 | 3 |
|---------------------------------|---|---|---|
| Application | | | |
| KNX | 1 | 1 | 1 |
| Cool - 2 pipe | 1 | 1 | 0 |
| Cool - 2 pipe 3pt (on/off only) | 1 | 0 | 1 |
| Heat - 2 pipe | 0 | 0 | 1 |
| Heat - 2 pipe 3pt (on/off only) | 0 | 1 | 0 |
| Heat - 2 pipe w. heater | 0 | 1 | 1 |
| Cool/Heat - 4pipe | 0 | 0 | 0 |
| Reserve | 1 | 0 | 0 |

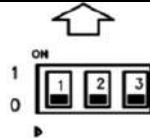

Caldion room temperature controller can operate in two different operating mode, with and without KNX bus connection through different setting configuration of the DIP switch.

- Network mode

In network mode, user first needs to use ETS to parameterize the configuration of Caldion room temperature controller, then using full download in ETS to enable the Caldion to operate in the downloaded configuration.

Note: Whenever Caldion is activated to operate in network mode, a new ETS full download is require else the Caldion will display the following page.

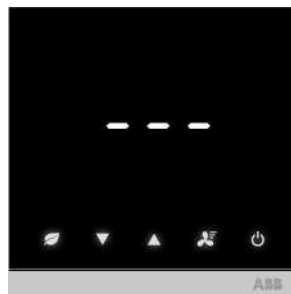

- Standalone mode

In standalone mode, no ETS configuration and KNX bus connection is required. User is only required to configure the setting via DIP switch according to the desired application in the field.

9.1 Network mode (software)



Note

The devices are products of the KNX system and meet KNX guidelines. Detailed expert knowledge by means of KNX training sessions for a better understanding is assumed.

To start the device a physical address must be assigned first. The physical address is assigned, and the parameters are set with the Engineering Tool Software ETS (from version ETS 4.2 – Build 3884, ETS 5).

9.1.1 Preparatory steps

1. Connect a PC via the KNX interface, e.g. the commissioning interface / adapter IP/S 3.1.1, to the KNX bus line. The Engineering Tool Software ETS (from version ETS 4.2 – Build 3884, ETS 5) must have been installed on the PC.
2. Switch on the supply and bus voltage.

9.1.2 Assigning a physical address

Use a tool to press the programming button at the bottom of the device (left side, specified hole). The diameter of the tool should be less than 2mm.

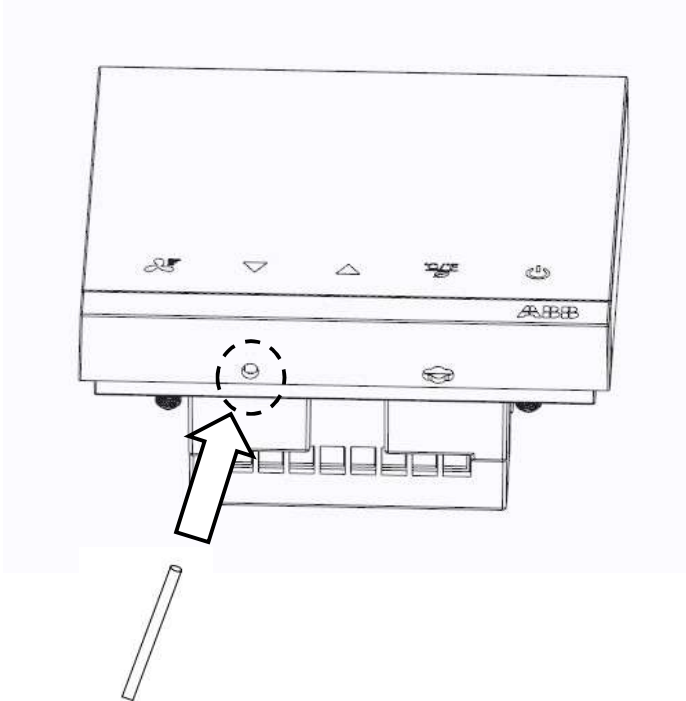

9.1.3 Assigning the group address(es)

The group addresses are assigned in connection with the ETS.

9.1.4 Selecting the application program

Please contact our Internet support unit (www.abb.com/KNX). The application is loaded into the device via the ETS.

9.1.5 Differentiating the application program

Various functions can be implemented via the software application (ETS) (detailed descriptions of parameters are contained as Help text in chapter "Application ..." (only in languages of the countries EN and CN).

9.2 Standalone Mode

A set of configurations was predefined in the FW corresponding to different standalone applications as below.

- 2 pipes, cooling
- 2 pipes, cooling, 3 points valves (For On/Off only)
- 2 pipes, heating
- 2 pipes, heating, 3 points valves (For On/Off only)
- 2 pipes, heating, with electric heater
- 4 pipes, heating and cooling

Binary input parameter is predefined when device is in standalone mode.

| | |
|-----------------------|---|
| Input on E1 (input a) | Will be used for identifying the state of window contact, contact open recognized as window open  Note: Need to be connected with cable if no window contact is available, without cable connected, device will be activated in building protection mode. |
| Input on E2 (input b) | Will be used for the temperature measurement, an external temperature sensor (NTC10-01:10K: B-Constant at 50°C=3936~3976) shall be connected if required |

Upon the DIP setting, corresponding configuration will be loaded as active configuration that the device used to work with.

10 Operation

10.1 Control buttons

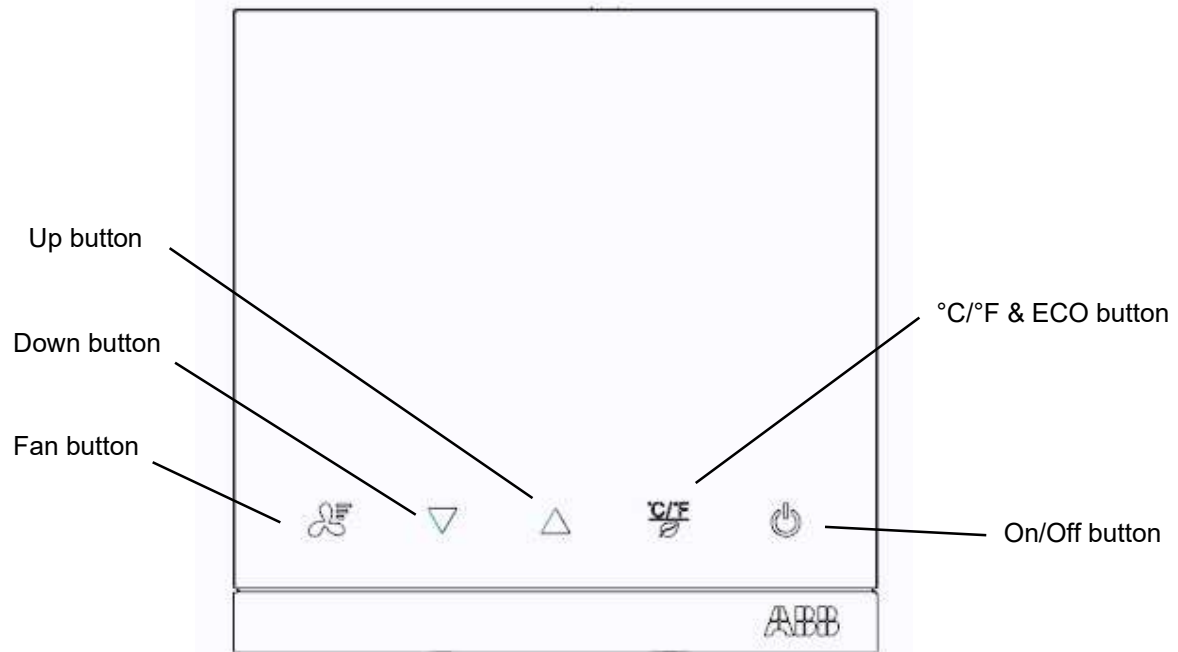

10.1.1 On/Off RTC and setting of operating mode

The function will only be available if RTC is configured to have heating and cooling function. Default setting: A short press on the On/Off button will enter turn RTC on or off. A long press on the On/Off button, it will switch between heating and cooling operating mode.

10.1.2 °C/°F switching and ECO mode

A short press on the °C/°F button will switch between °C and °F. A long press will activate RTC to go into ECO mode.

10.1.3 Setting of the setpoint temperature

A short press on the up or down button will adjust the setpoint temperature by 0.5 °C. A long press on the up or down button will have the temperature setpoint increase or decrease by 0.5 degrees continuously.

10.1.4 Setting of Fan speed

A single press on the fan button will adjust the fan speed. Long press on the fan button will not react. Fan speed adjustment will be in a looping sequence. Example: 0 > 1 > 2 > 3 > Auto > 0

11 Cleaning



Caution! - Risk of damaging the device!

- The voltage supply to the device must be switched off before cleaning.
 - When spraying on cleaning agents, these can enter the device through crevices.
 - Do not spray cleaning agents directly onto the device.
 - Aggressive cleaning agents can damage the surface of the device.
 - Never use caustic agents, abrasive agents or solvents
- Clean dirty devices with a soft dry cloth.
 - If this is insufficient, the cloth can be moistening slightly with a soap solution.

12 Maintenance

The unit is maintenance-free. In case of damage (e.g., during transport or storage), do not perform repairs. Once the unit is open, the warranty is void!

13 Description of applications / Objects

13.1 Overview of parameters

The parameters for the room temperature controller contain the following:

| |
|------------------------------|
| General |
| Application parameters |
| Device function |
| Temperature controller |
| Basic-stage heating |
| Additional-stage heating |
| Basic-stage cooling |
| Additional-stage cooling |
| Setpoint manager |
| Monitoring and safety |
| Valve output A |
| Valve output B |
| Fan output |
| Electric heater relay output |
| Setpoint adjustment |
| Input a |
| Input b |
| Internal temperature sensor |

13.2 Parameters

13.2.1 General – Sending and switching delay after 230V recovery

| | |
|---------|--------|
| Options | 2..255 |
|---------|--------|

During the sending and switching delay, telegrams are only received. However, the telegrams are not processed, and the outputs remain unchanged. No telegrams are sent on the bus. After the sending and switching delay, telegrams are sent, and the state of the outputs is set to correspond with the parameterization or the group object values. If group objects are read out via the bus during the sending and switching delay, e.g. by a visual display system, these requests are stored, and a response is sent once the delay time has expired. An initialization time of about two seconds is included in the delay time. The initialization time is the time that the processor requires before it is ready to function.



Note: After 230V recovery, the device always waits for the sending delay time to lapse before sending telegrams via the bus. The switching delay does not apply to the parameterized behavior of the outputs.

13.2.2 General – State after sending and switching has elapsed

| | |
|---------|---|
| Options | Last value received Ignore receives values |
|---------|---|

Last value received: During the sending and switching delay, the inputs and outputs continue reading. They send the current value after the delay has elapsed. Ignore

received values: No new values are accepted during the sending and switching delay. The first value received after the sending and switching delay has elapsed applies.

13.2.3 General – Limited number of telegrams

| | |
|---------|-----------|
| Options | No Yes |
|---------|-----------|

This parameter limits the device-generated bus load. This limit relates to all telegrams sent by the device.

13.2.4 General – Maximum number of telegrams

| | |
|---------|-------|
| Options | 1..50 |
|---------|-------|

This parameter defines the number of telegrams sent by the device within a certain period of time. The telegrams are sent as quickly as possible at the start of a period. The device counts the number of telegrams sent within the parametrized period. As soon as the maximum number of sent telegrams is reached, no further telegrams are sent on the KNX bus until the end of the period. A new period commences at the end of the previous period. The telegram counter is reset to zero, and sending of telegrams is allowed again. The current group object value at the time of sending is always sent. The first period (break time) is not precisely predefined. It can be anywhere between zero seconds and the parametrized time. The subsequent sending times correspond with the parametrized time.

Example:

Maximum number of sent telegrams = 5, period = 5 s. 20 telegrams are ready to send. The device immediately sends 5 telegrams. The next 5 telegrams are sent after a maximum of 5 seconds. From this point, a further 5 telegrams are sent on the KNX every 5 seconds. The telegrams are sent in the order in which they arise (first in - first out).



Note: Dependent parameter: Limited number of telegrams

13.2.5 General – In period

| | |
|---------|--|
| Options | 1 second 2 second 5 second 10 second 30 second 1 minute |
|---------|--|

This parameter defines the number of telegrams sent by the device within a certain period of time. The telegrams are sent as quickly as possible at the start of a period. The device counts the number of telegrams sent within the parametrized period. As soon as the maximum number of sent telegrams is reached, no further telegrams are sent on the KNX bus until the end of the period. A new period commences at the end of the previous period. The telegram counter is reset to zero and sending of telegrams is allowed again. The current group object value at the time of sending is always sent. The first period (break time) is not precisely

predefined. It can be anywhere between zero seconds and the parametrized time. The subsequent sending times correspond with the parametrized time.

Example:

Maximum number of sent telegrams = 5, period = 5 s. 20 telegrams are ready to send. The device immediately sends 5 telegrams. The next 5 telegrams are sent after a maximum of 5 seconds. From this point, a further 5 telegrams are sent on the KNX every 5 seconds. The telegrams are sent in the order in which they arise (first in - first out).



Note: Dependent parameter: Limited number of telegrams

13.2.6 General – Enable group object "In operation", 1 bit

| | |
|---------|-----------|
| Options | No Yes |
|---------|-----------|

The "In operation" object is enabled if the parameter Enable group object "In operation", 1 bit is set to "Yes" in the parameter window. In order to regularly monitor the presence of the device on the KNX, a telegram "In operation" object is sent cyclically on the bus. As long as the group object is activated, it sends a parameterizable "In operation" telegram. The telegram value depends on the option selected in parameter "Send".

13.2.7 General – Value to be send cyclic for "In operation"

| | |
|---------|--------------------|
| Options | Value 0 Value 1 |
|---------|--------------------|



Note: Dependent parameter: Enable group object "In operation", 1 bit

13.2.8 General – Sending cycle time

| | |
|---------|----------------------|
| Options | 00:00:01 to 18:12:15 |
|---------|----------------------|

The time interval at which the "In operation" group object cyclically sends a telegram is set here. After 230V recovery, the group object sends its value after the sending and switching delay set.



Note: Dependent parameter: Enable group object "In operation", 1 bit

13.2.9 General – Display illumination

| | |
|---------|---|
| Options | Illumination efficient Constantly on |
|---------|---|

To parameter display illumination setting. During operation: if Display illumination is set to "illumination efficient": display screen will be turn off after a set duration of time from last trigger command as device enter into illumination efficient mode. If Display illumination is set to "Constantly on": Display screen will remain active and permanently on.

13.2.10 General – Display illumination activate / deactivate by group object

| | |
|---------|--|
| Options | Inactive 1 = Illumination efficient / 0 = Constantly on 1 = Constantly on / 0 = Illumination efficient |
|---------|--|

If "Display illumination activate / deactivate by group object" parameter is activated, display illumination would be control via the 1-bit communication object "Display illumination".

Scenario: If Display illumination is set to "Illumination efficient" and Display illumination activate / deactivate by group object is "1 = Illumination efficient / 0 = Constantly on". Sending of Display illumination group object = 1, display illumination will be turn off after a set duration of time from last trigger command as device enter into illumination efficient mode. Sending of Display illumination group object = 0, Display illumination will remain active and permanently on. During illumination efficient mode, any touch on the device for change of setting will turn on the display illumination for time duration set in "Time for display illumination to turn off after last trigger", after the time is lapse, the display illumination will turn off and wait for next touch on the device.

13.2.11 General – Time for display illumination to turn off after last trigger

| | |
|---------|----------------------|
| Options | 00:00:01 to 18:12:15 |
|---------|----------------------|

To parameter the duration of display illumination remaining active after last trigger button. Time will start to count down after last trigger touch. After time is lapse, display illumination will turn off as device enter into illumination efficient mode.

13.2.12 General – Button icon LED illumination

| | |
|---------|---|
| Options | Illumination efficient Constantly on |
|---------|---|

To parameter button icon LED illumination setting. During operation, Button icon LED illumination is set to "Illumination efficient": Button icon LED illumination will be turn off as device enter into illumination efficient mode. Button icon LED illumination is set to "Constantly on". Button icon LED illumination will remain active and permanently on.

13.2.13 General – Button icon LED illumination activate / deactivate by group object

| | |
|---------|--|
| Options | Inactive 1 = Illumination efficient / 0 = Constantly on 1 = Constantly on / 0 = Illumination efficient |
|---------|--|

Scenario: If Button icon LED illumination is set to "Illumination efficient" and Button icon LED illumination activate / deactivate by group object is "1 = Illumination efficient / 0 = Constantly on". Sending of Button icon LED illumination group object = 1, button icon LED illumination will be turn off immediately after receiving group object = 1, or after a setting duration of time from last trigger command, it will off the LED illumination and enter into illumination efficient mode. Sending of Button icon LED illumination group object = 0, Button icon LED illumination will remain active and

permanently on. During illumination efficient mode, any touch on the device for change of setting will turn on the Button icon LED illumination for time duration set in "Time for Button icon LED illumination to turn off after last trigger", after the time is lapse, the Button icon LED illumination will turn off and await for next touch on the device.

13.2.14 General – Time for button icon LED illumination to turn off after last trigger

| | |
|---------|----------------------|
| Options | 00:00:01 to 18:12:15 |
|---------|----------------------|

To parameter the duration of button icon LED illumination remaining active after last trigger button. Time will start to count down after last trigger touch. After time is lapse, button icon LED illumination will turn off as device enter into illumination efficient mode.

13.2.15 General – Button icon first touch function when device is in standby mode

| | |
|---------|--|
| Options | Awake and send command Awake device |
|---------|--|

To parameter the first touch on the button icon when the device is in standby mode, first touch on the button icon to trigger the command or first touch on the button icon to awake the device.

13.2.16 General – On/Off button control function

| | |
|---------|--|
| Options | Short-On/Off, Long-Mode change Short-Mode change, Long-On/Off |
|---------|--|

To parameter On/Off and Mode selection control of the device via On/Off button icon. On/Off button icon of device set to "Short-On/Off, Long-Mode change" device will On/Off by a short press on the On/Off button icon, device will change the operating mode by a long press on the On/Off button. On/Off button icon of device set to "Short-Mode change, Long-On/Off", device will change the operating mode by a short press on On/Off button icon, device will On/off by a long press on the On/Off button icon.



Note: Mode selection control will only be available when RTC have the option of cooling and heating operation mode. When device is in cooling or heating operation mode only, long press will have no functionality effect. Mode selection: If "Short press-On/Off, Long press-Mode select" is selected. Long press will switch over the operating mode from heating to cooling or vice versa cooling to heating immediately.

13.2.17 General – Behavior after switching on

| | |
|---------|--|
| Options | Default value Recovery last setting |
|---------|--|

To parameter the setting of operation when the device is turn on after it is off. Behavior after switching on set to "default", every time when the device is turn on after it is off, device setpoint and fan speed will be in default value. On/Off reaction set to "recovery last setting", every time when the device is turn on after it is off, device setpoint and fan speed will be set to the setting values before it is turn off.

Temperature display type and unit will not be affected, it will remain as per the parameter setting.

13.2.18 General – Behavior after switching on by group object

| | |
|---------|--|
| Options | Inactive 1 = default value / 0 = recovery last setting 1 = recovery last setting / 0 = default value |
|---------|--|

To parameter the setting of operation when the device is turn on after it is off via group object. Behavior after switching on by group object set to "default", every time when the device is turn on after it is off, device setpoint and fan speed will be in default value. Behavior after switching on by group object set to "recovery", every time when the device is turn on after it is off, device setpoint and fan speed will be set to the setting values before it is turn off.

13.2.19 General – °C/°F + ECO button control function

| | |
|---------|--|
| Options | Short-°C/°F, Long-ECO mode Short-ECO mode, Long-°C/°F |
|---------|--|

To parameter °C/°F + ECO button control of the device via °C/°F + ECO button icon. °C/°F + ECO button control function of device set to " Short-°C/°F, Long-ECO mode" device will switch over °C/°F units by a short press on the °C/°F + ECO button icon, device will enter into ECO mode by a long press on the °C/°F + ECO button icon. °C/°F + ECO button control function of device set to " Short-ECO mode, Long-°C/°F ", device will enter in to ECO mode by a short press on °C/°F + ECO button icon, device will switch over °C/°F units by a long press on the °C/°F + ECO button icon.

13.2.20 General – Device to be lock / unlock by group object

| | |
|---------|--|
| Options | Inactive 1 =lock / 0 =unlock 1 = unlock / 0 = lock |
|---------|--|

To parameter lock / unlock of device via group object. Device to be lock / unlock by group object set to activate, device function would be control via the 1-bit communication object "Device function". When device is lock, device will operate as per last setting function before it is lock and local button function will be inactive. When device is unlocked, normal operation will be in place.



Note: If device display does not set as constantly on. Display will turn off when the time duration is lapse. Any touch of the button will turn on the display but will not perform the function

13.2.21 General – Temperature display

| | |
|---------|--------------------------------------|
| Options | Setpoint temp Actual measure temp |
|---------|--------------------------------------|

To parameter temperature display value. Setpoint temp: display of the temperature that user set. Actual measure temp: display of temperature that is measure from in build temperature sensor.



Note: If Actual measure temperature display is selected. Adjusting of temperature, display will temporary switch to setpoint display to show adjusting temperature. 3 second after completion on adjustment of the setpoint, display will switch back to display of actual temperature reading.

13.2.22 General – Temperature display units

| | |
|---------|----------|
| Options | °C °F |
|---------|----------|

To parameter temperature display unit.

13.2.23 General – Switchover temperature display units via group object

| | |
|---------|--|
| Options | Inactive 1 = °C / 0 = °F 1 = °F / 0 = °C |
|---------|--|

To switchover between °C and °F using 1-bit communication object

13.2.24 General – Status byte device

This group object is always enabled and indicates the current device state. It indicates whether the device is working normally or whether manual override is in effect.

This group object maps the following information:

- Bit 0: Operating mode overridden

The RTC was overridden via the group object Operating mode override.

- 0: No override
- 1: Override active

- Bit 1: Building Protection

The device is in Building Protection mode due to dew point/fill level alarm or an open window

- 0: Building protection inactive
- 1: Building protection active

- Bit 2: Forced operation

Forced operation was activated.

- 0: Forced operation inactive
- 1: Forced operation active

- Bit 5: Security Mode

The device is in Security Mode, e.g. due to temperature value or control value failure; a defined control value applies.

13.2.25 General – Request status values

This group object is always enabled. When this group object receives a telegram with the value 0 or 1, all group objects Status are sent on the bus if they were parametrized with "On request".

13.2.26 Application Parameters - Basic-stage heating

| | |
|---------|--|
| Options | Deactivated Convactor (e.g. radiator) |
|---------|--|

| | |
|--|--|
| | Area heating (e.g. floor) Electric heater (in room) Free configuration Fan coil unit: electric heater (in fan coil unit) Fan coil unit: Water heating coil |
|--|--|

The type of application for the heating stage is selected with this parameter. The controller is preconfigured based on this selection and can be used for the selected application.

- Deactivated: The heating stage is deactivated by selecting this option. All dependent parameters and parameter windows are also deactivated.
- Convector (e.g. radiator): This option should be selected if a convector, e.g. a radiator, is used as the heating stage. The Basic heating stage control value type parameter is pre-parameterized to PI continuous (0...100 %) with the corresponding P and I proportion.
- Area heating (e.g. floor): This option should be selected if an area, e.g. floor heating, is used as the heating stage. The Basic heating stage control value type parameter is pre-parameterized to PI continuous (0...100 %) with the corresponding P and I proportions.
- Electric heater (in room): This option should be selected if an electric heater in the room is used as the heating stage and for this heater the fan does not need to run as well in operation. The Basic heating stage control value type parameter is pre-parameterized to 2-point 1 bit (On/Off).
- Free configuration: With this option it is possible to select freely the type of heating stage and also the type of control. This option can be selected if the type of application is not entirely clear or if specific adjustments are necessary. The Basic heating stage control value type parameter is pre-configured to PI continuous (0...100 %), however it is possible to select freely between all control types.
- Fan coil unit: electric heater (in fan coil unit): This option should be selected if an electric heater in the fan coil unit is used as the heating stage and the fan must therefore also run in operation. The Basic heating stage control value type parameter is pre-parameterized to 2-point 1 bit (On/Off).
- Fan coil unit: Water heating coil: This option should be selected if the water heating coil in the fan coil unit is used as the heating stage. The Basic-stage heating control value type parameter is pre-parameterized to PI continuous (0...100 %) for Fan Coil with the corresponding P and I proportions.



Note: On the selection of the Fan coil unit: electric heater or Fan coil unit: Water heating coil options, the fan follows the valve control value for this stage if the automatic mode is active. On the selection of the Free configuration option, this can also be set via a parameter.

13.2.27 Application Parameters - Additional-stage heating

| | |
|---------|--|
| Options | Deactivated Convector (e.g. radiator) Area heating (e.g. floor) Electric heater (in room) Free configuration Fan coil unit: electric heater (in fan coil unit) Fan coil unit: Water heating coil |
|---------|--|

This parameter is visible if Basic-stage heating parameter is activated. The type of application for the additional-stage heating is selected with this parameter. The controller is pre-configured based on this selection and can be used for the selected application.

- Deactivated: The heating stage is deactivated by selecting this option. All dependent parameters and parameter windows are also deactivated.
- Convector (e.g. radiator): This option should be selected if a convector, e.g. a radiator, is used as the heating stage. The Basic heating stage control value type parameter is pre-parameterized to PI continuous (0...100 %) with the corresponding P and I proportions.
- Area heating (e.g. floor): This option should be selected if an area, e.g. floor heating, is used as the heating stage. The Basic heating stage control value type parameter is pre-parameterized to PI continuous (0...100 %) with the corresponding P and I proportions.
- Electric heater (in room): This option should be selected if an electric heater in the room is used as the heating stage and for this heater the fan does not need to run as well in operation. The Basic heating stage control value type parameter is pre-parameterized to 2-point 1 bit (On/Off).
- Free configuration: With this option it is possible to select freely the type of heating stage and also the type of control. This option can be selected if the type of application is not entirely clear or if specific adjustments are necessary. The Basic heating stage control value type parameter is pre-configured to PI continuous (0...100 %), however it is possible to select freely between all control types.
- Fan coil unit: electric heater (in fan coil unit): This option should be selected if an electric heater in the fan coil unit is used as the heating stage and the fan must therefore also run in operation. The Basic heating stage control value type parameter is pre-parameterized to 2-point 1 bit (On/Off).
- Fan coil unit: Water heating coil: This option should be selected if the water heating coil in the fan coil unit is used as the heating stage. The Basic-stage heating control value type parameter is pre-parameterized to PI continuous (0...100 %) for Fan Coil with the corresponding P and I proportions.



Note: On the selection of the Fan coil unit: electric heater or Fan coil unit: Water heating coil options, the fan follows the valve control value for this stage if the automatic mode is active. On the selection of the Free configuration option, this can also be set via a parameter

13.2.28 Application Parameters - Basic-stage cooling

| | |
|---------|---|
| Options | Deactivated Area cooling (e.g. cooling ceiling) Free configuration Fan coil unit: Water cooling coil |
|---------|---|

The type of application for the basic-stage cooling is selected with this parameter. The controller is pre-configured based on this selection and can be used for the selected application.

- Deactivated: The basic-stage cooling is deactivated by selecting this option. All dependent parameters and parameter windows are also deactivated.
- Area cooling (e.g. cooling ceiling): This option should be selected if an area, e.g. cooling ceiling, is used as the basic-stage cooling.

The Basic-stage cooling control value type parameter is pre-parameterized to PI continuous (0...100%) with the corresponding P and I proportions.

- Free configuration: With this option it is possible to select freely the type of basic-stage cooling and also the type of control. This option can be selected if the type of application is not entirely clear or if specific adjustments are necessary. The Basic-stage cooling control value type parameter is pre-configured to PI continuous (0...100%), however it is possible to select freely between all control types.
- Fan coil unit: Water cooling coil: This option should be selected if the water heating coil in the fan coil unit is used as the basic-stage cooling. The Basic-stage cooling control value type parameter is pre-parameterized to PI continuous (0...100%) for Fan Coil with the corresponding P and I proportion.



Note: On the selection of the Fan coil unit: Water cooling coil options, the fan follows the valve control value for this stage if the automatic mode is active. On the selection of the Free configuration option, this can also be set via a parameter.

13.2.29 Application Parameters - Additional-stage cooling

| | |
|---------|---|
| Options | Deactivated Area cooling (e.g. cooling ceiling) Free configuration Fan coil unit: Water cooling coil |
|---------|---|

This parameter is visible if Basic-stage cooling parameter is activated. The type of application for the additional-stage cooling is selected with this parameter. The controller is pre-configured based on this selection and can be used for the selected application.

- Deactivated: The additional-stage cooling is deactivated by selecting this option. All dependent parameters and parameter windows are also deactivated.
- Area cooling (e.g. cooling ceiling): This option should be selected if an area, e.g. cooling ceiling, is used as the additional-stage cooling. The Additional-stage cooling control value type parameter is pre-parameterized to PI continuous (0...100%) with the corresponding P and I proportions.
- Free configuration: With this option it is possible to select freely the type of additional-stage cooling and also the type of control. This option can be selected if the type of application is not entirely clear or if specific adjustments are necessary. The Additional-stage cooling control value type parameter is pre-configured to PI continuous (0...100%), however it is possible to select freely between all control types.
- Fan coil unit: Water cooling coil: This option should be selected if the water heating coil in the fan coil unit is used as the additional-stage cooling. The Additional-stage cooling control value type parameter is pre-parameterized to PI continuous (0...100%) for Fan Coil with the corresponding P and I proportion.



Note: On the selection of the Fan coil unit: Water cooling coil options, the fan follows the valve control value for this stage if the automatic mode is active. On the selection of the Free configuration option, this can also be set via a parameter

13.2.30 Application Parameters - Type of heating/cooling system

| | |
|---------|------------------|
| Options | 2-pipe 4-pipe |
|---------|------------------|

- 2-pipe: This option is to be selected if the heating and cooling devices actuated are in a 2-pipe system. In this system, only one pipe is used to supply the device with hot and cold water. It is therefore only ever possible to heat or cool; a changeover is necessary to change. It follows that the device is not allowed to decide on a change between heating and cooling and the changeover must always be made via the bus. The Heating/Cooling changeover parameter is correspondingly parameterized to Via object only and cannot be changed.
- 4-pipe: This option is to be selected if the devices actuated are in a 4-pipe system. In a 4-pipe system, separate pipes are used for the hot and cold water supply. It is therefore possible to change between heating and cooling at any time. In this situation the decision can be made centrally, and also by the device. The Heating/Cooling changeover parameter is correspondingly parameterized to Automatically.

13.2.31 Application Parameters - Heating/Cooling changeover

| | |
|---------|--|
| Options | Automatically Via object only Via On/Off button and slave and object |
|---------|--|

The standard value for this parameter depends on the selection in the Type of heating/cooling system parameter.

- Selection of 4-pipe:
 - Automatically: If the Automatically option is selected, the changeover is only made by the controller for the device depending on the setpoint temperature selected. Here the Heating/Cooling changeover group object is hidden.
 - Via object only: Changeover of the heating and cooling is allowed from a centrally visualization or a building management system, e.g. if the cooling equipment and heating equipment are not to operate at the same time for energy-saving reasons, this parameter can also be changed by the group object.
 - Via On/Off button and slave and object: The Heating/Cooling changeover and Request heating/cooling (master) group objects are visible. It is possible to trigger a change between heating and cooling via the bus using these group objects. The Request heating/cooling (master) group object is used for connecting to a slave analog room control unit in the context of master/slave communication. The Heating/Cooling changeover group object is visible. Another method of changeover is by long press on the physical button (On/Off button) on the device itself.

- Selection of 2-pipe:

If 2-pipe has been selected, the standard value is set to Via object only and cannot be changed; the related Heating/Cooling changeover group object is visible. In a 2-pipe system, the same pipe is used for the supply of hot and cold water. Because the device cannot detect which situation is present, the changeover must always be made centrally and sent to the device using a group object.

13.2.32 Application Parameters - Use 6 way valve

| | |
|---------|-----------|
| Options | No Yes |
|---------|-----------|

This parameter is used to parameterize the usage of a 6-way valve on the device. The 6-way valve is used to control both the heating and cooling stages at the same time. For this purpose, the drive in the 6-way valve is connected to valve output A and the control values for heating and cooling are output on this output. The usage of a 6-way valve is only possible for the two basic stages. If one of the basic stages has been deactivated or the basic-stage heating is used for a non-water type of heating (e.g. electric heater), it is not possible to use a 6-way valve. To prevent an erroneous configuration, none of the dependent parameters can be changed as long as the usage of a 6-way valve is parameterized.

If Yes has been selected, the dependent parameter Valve type in the Valve output A parameter window is pre-configured to 6-way valve. The Actuate basic-stage heating via and Actuate basic-stage cooling via parameters are set to Output A.



Note: This parameter is not visible if the Basic-stage heating or Basic-stage cooling parameters are deactivated. This parameter is also only visible if the 4-pipe option has been selected in the Type of heating/cooling system parameter. Only applicable for 0~10V version.

13.2.33 Application Parameters - Actuate basic-stage heating via

| | |
|---------|---|
| Options | Internal relay output Internal output A (valve) Internal output B (valve) Group object |
|---------|---|

The way the control value for the basic-stage heating is to be output is set using this parameter. Depending on the selection in the Basic-stage heating parameter, it may not be possible to select all options.

Example:

If, in the Basic-stage heating parameter, the Fan coil unit: electric heater (in fan coil unit) option is selected, Depending on Actuate basic-stage cooling via, Actuate additional-stage heating and Actuate additional-stage cooling via selection. If any of the parameter have selected valve output A, basic-stage can only select from Valve B and group object. If any of the parameter have selected valve output A and value output B, basic-stage can only have one option: group object. Depending on the option selected in the Basic-stage heating parameter, this parameter may have a different standard value. The settings for the exact control parameters are made in the Temperature controller – Basic stage heating parameter window. The settings for the actuation of the control values via the valve outputs are made in the related valve parameter window.

- Internal output A (valve); Internal output B (valve); Internal relay output: If one of the internal outputs is selected, the control value is output directly on this physical output where it is converted into the corresponding output signal. The outputs A and B are used to actuate valve drives, if the valve is require to actuate an electric heater. It will need to be connected to additional external relay or contactor. In parallel to the actuation via the corresponding internal output, the control value is also output via the related Status Control value Basic-stage heating group object.
- Group object: If Group object has been selected as the option, there is no actuation via any of the internal outputs, instead the control value is only output on the bus. The control value is output via the related Status Control value Basic-stage heating

group object.



Note: This parameter is not visible if the Basic-stage heating parameter is deactivated.

13.2.34 Application Parameters - Actuate basic-stage cooling via

| | |
|---------|--|
| Options | Internal output A (valve) Internal output B (valve) Group object |
|---------|--|

The way the control value for the basic-stage cooling is to be output is set using this parameter. Depending on the selection in the Actuate basic-stage heating via parameter, it may not be possible to select all options. If one of the outputs has already been selected, it cannot also be used as an output for the basic-stage cooling.

(Selection in the Type of heating/cooling system parameter: 4-pipe)

Depending on the option selected in the Actuate basic-stage heating via parameter, this parameter may have a different standard value. The settings for the exact control parameters are made in the Temperature controller – Basicstage cooling parameter window. The settings for the actuation of the control values via the valve outputs are made in the related valve parameter window.

Example:

If the Internal output A (valve) option has been selected as the output for the basic-stage heating, this cannot be selected as the output for the basic-stage cooling. Conversely, this statement also applies on the selection of Internal output B (valve).

(Selection in the Type of heating/cooling system parameter: 2-pipe)

In a 2-pipe system, heating and cooling are undertaken using the same device (e.g. fan coil unit). Here it is possible that either the same valve is used for heating and cooling or that two valves are used because the heat/cooling is output into the room via a dedicated heating/cooling coil. For this reason, it is therefore possible here to output the control values for heating and cooling on the same output.

- Internal output A (valve); Internal output B (valve): If one of the internal outputs is selected, the control value is output directly on this physical output where it is converted into the corresponding output signal. The outputs A and B are used to actuate valve drives. In parallel to the actuation via the corresponding internal output, the control value is also output via the related Status Control value Basic-stage cooling group object.
- Group object: If Group object has been selected as the option, there is no actuation via any of the internal outputs, instead the control value is only output on the bus. The control value is output via the related Status Control value Basic-stage cooling group object.



Note: This parameter is not visible if the Basic-stage cooling parameter is deactivated.

13.2.35 Application Parameters - Actuate additional-stage heating via

| | |
|---------|---|
| Options | Internal relay output Internal output A (valve) Internal output B (valve) Group object |
|---------|---|

The way the control value for the additional-stage heating is to be output is set using this parameter. The parameter options are dependent on the values selected in the Additional-stage heating, Actuate basic-stage heating via and Actuate basic-stage cooling via parameters.

4-pipe system (selection in the Type of heating/cooling system parameter: 4-pipe): Depending on the selection in the Actuate basic-stage heating via and Basic-stage cooling parameters, it may not be possible to select all options. If one of the outputs has already been selected here, then it cannot also be used as an output for the additional-stage heating. The settings for the exact control parameters are made in the Temperature controller – Additional-stage heating parameter window. The settings for the actuation of the control values via the valve outputs are made in the related valve parameter window.

Example:

If the Internal output A (valve) option has been selected as the output for the basic-stage heating, this cannot be selected as the output for the additional-stage heating.

2-pipe system (selection in the Type of heating/cooling system parameter: 2-pipe): In a 2-pipe system, heating and cooling are undertaken using the same device (e.g. fan coil unit). Here it is possible that either the same valve is used for heating and cooling or that two valves are used because the heat/cooling is output into the room via a dedicated heating/cooling coil. For this reason, it is therefore possible here to output the control values for heating and cooling on the same output.

- Internal output A (valve); Internal output B (valve): If one of the internal outputs is selected, the control value is output directly on this physical output where it is converted into the corresponding output signal. The outputs A and B are used to actuate valve drives. In parallel to the actuation via the corresponding internal output, the control value is also output via the related Status Control value Additional-stage heating group object.
- Group object: If Group object has been selected as the option, there is no actuation via any of the internal outputs, instead the control value is only output on the bus. The control value is output via the related Status Control value Additional-stage heating group object.



Note: This parameter is not visible if the Additional-stage heating parameter is deactivated.

13.2.36 Application Parameters - Actuate additional-stage cooling via

| | |
|---------|--|
| Options | Internal output A (valve) Internal output B (valve) Group object |
|---------|--|

The way the control value for the additional-stage cooling is to be output is set using this parameter. The parameter options are dependent on the values selected in the

Additional-stage heating, Actuate basic-stage heating via, Actuate basic-stage cooling via and Actuate additional-stage heating via parameters. The settings for the exact control parameters are made in the Temperature controller – Additional-stage cooling parameter window. The settings for the actuation of the control values via the valve outputs are made in the related valve parameter window.

4-pipe system (selection in the Type of heating/cooling system parameter: 4-pipe): Depending on the selection in the Actuate basic-stage heating via, Basic-stage cooling and Additional-stage heating parameters, it may not be possible to select all options. If one of the outputs has already been selected here, then it cannot also be used as an output for the basic-stage cooling. The settings for the exact control parameters are made in the Temperature controller – Additional-stage cooling parameter window. The settings for the actuation of the control values via the valve outputs are made in the related valve parameter window.

Example:

If the Internal output A (valve) option has been selected as the output for the basic-stage heating, this cannot be selected as the output for the additional-stage cooling. Conversely, this statement also applies on the selection of Internal output B (valve).

2-pipe system (selection in the Type of heating/cooling system parameter: 2-pipe): In a 2-pipe system, heating and cooling are undertaken using the same device (e.g. fan coil unit). Here it is possible that either the same valve is used for heating and cooling or that two valves are used because the heat/cooling is output into the room via a dedicated heating/cooling coil.

For this reason it is therefore possible here to output the control values for heating and cooling on the same output. In parallel to the actuation via the corresponding internal output, the control value is also output via the related Status Control value basic heating stage group object.

- Internal output A (valve); Internal output B (valve): If one of the internal outputs is selected, the control value is output directly on this physical output where it is converted into the corresponding output signal. The outputs A and B are used to actuate valve drives. In parallel to the actuation via the corresponding internal output, the control value is also output via the related Status Control value Additional-stage cooling KNX group object.
- Group object: If Group object has been selected as the option, there is no actuation via any of the internal outputs, instead the control value is only output on the bus. The control value is output via the related Status Control value Additional-stage cooling group object.



Note: This parameter is not visible if the Additional-stage cooling parameter is deactivated

13.2.37 Application Parameters - Switch relay output independently of fan speed (including when fan = 0)

| | |
|---------|-----------|
| Options | No Yes |
|---------|-----------|

This parameter is used to set whether switching of the relay output (valve) is to be allowed, independently of whether the fan is running or not. The switching is undertaken via valve communication object



Note: This parameter is only visible if either Electric heater (in room) or Fan coil unit: electric heater (in fan coil unit) option has been selected for either Actuate basic-stage heating via or Actuate additional-stage heating via

13.2.38 Application Parameters - Automatic reset of manual relay overdrive to controller operation after

| | |
|---------|----------------------|
| Options | 00:00:30 to 18:12:15 |
|---------|----------------------|

This parameter defines when switching of the relay outside the control is to be reset and controller operation activated again. For the time stated here the relay output can be overridden via the group object. Only after this time has elapsed is the control value specified by the controller applied again for the relay. A change in the operating mode from heating to cooling will always reset the relay manual override to controller operation.



Note: This parameter is only visible if Switch relay output independently of fan speed (including when fan = 0) option has been selected for either Actuate basic-stage heating via or Actuate additional-stage heating via.

13.2.39 Application Parameters - Window status input

| | |
|---------|--|
| Options | Deactivated Via physical device input Via group object |
|---------|--|

This parameter is used to inform the device whether it is to include the status of a window (open/closed) in the control.

- Deactivated: If Deactivated has been selected, the window status is not taken into account by the device.
- Via physical device input: If this option is selected, the device checks which of the physical device inputs has been parameterized for a window contact. The status of the window contact connected to this input is included in the control. The message: Configure in 'Inputs' parameter window appears. Only device inputs that have been parameterized as a window contact are detected as such. If no input has been parameterized as a window contact, the function is considered deactivated.

If several inputs have been parameterized as a window contact, there is a logical OR link between these inputs. As soon as one of the contacts signals the status "Window open", the controller evaluates the status as "Window open". Conversely, if all inputs signal the status "Window closed", the controller evaluates the status as "Window closed".

- Via group object: The window status is received via a group object. The dependent Window contact group object appears. In addition, the dependent Window open when parameter is enabled.

13.2.40 Application Parameters - Window open when

| | |
|---------|--------------------------------------|
| Options | Object value = 0 Object value = 1 |
|---------|--------------------------------------|

This parameter is used to select which object value is to be considered the window open status on reception. The device reacts to the reception of the "Window open" status by changing to Building Protection mode (building protection heating = frost protection, building protection cooling = protection against heat).

- Object value = 0: On the reception of the object value 0, it is evaluated as the "Window open" status. Reception of the object value 1 signifies "Window closed".
- Object value = 1: On the reception of the object value 1, it is evaluated as the "Window open" status. Reception of the object value 0 signifies "Window closed".



Note: This parameter is only visible if window status input "Via group object" is activated.

13.2.41 Application Parameters - Dew point status input

| | |
|---------|--|
| Options | Deactivated Via physical device input Via group object |
|---------|--|

This parameter is used to inform the device whether it is to include the dew point alarm (Alarm/No alarm) in the control.

- Deactivated: If Deactivated has been selected, the dew point alarm is not taken into account by the device.
- Via physical device input: If this option is selected, the device checks which of the physical device inputs has been parameterized for a dew point sensor. The status of the dew point sensor connected to this input is included in the control. The message: Configure in 'Inputs' parameter window appears. Only device inputs that have been parameterized as a dew point sensor are detected as such. If no input has been parameterized as a dew point sensor, the function is considered deactivated. If several inputs have been parameterized as a dew point sensor, there is a logical OR link between these inputs. As soon as one of the contacts signals the status "Dew point reached", the device evaluates the status as "Dew point alarm". Conversely, if none of the inputs signals the status "Dew point reached", the controller evaluates the status as "No dew point alarm".
- Via group object: The dew point alarm is received via a group object. The dependent Dew point alarm group object appears. In addition, the dependent Dew point reached when parameter is enabled.

13.2.42 Application Parameters - Dew point reach when

| | |
|---------|--------------------------------------|
| Options | Object value = 0 Object value = 1 |
|---------|--------------------------------------|

This parameter is used to select which object value is to be considered dew point reached on reception. The device reacts to the reception of the "Dew point alarm" status with the shutdown of the cooling and a changeover to Building Protection mode. This mode applies until the dew point alarm is cleared. However, a change to the heating mode (if possible) is allowed at any time. Here the device continues to operate normally because the dew point only relates to the cooling and heating counteracts the dropping below the dew point temperature. The dew point (or dew point temperature) is the temperature below which condensation is formed. At this temperature the relative humidity is 100 %. The air can therefore not absorb any moisture. Due to the formation of condensation, the building may be damaged

(damp/formation of mold). The dew point can be calculated based on the temperature and moisture values or measured by a sensor. To prevent dropping below the dew point, the cooling must be reduced or stopped.

- Object value = 0: On the reception of the object value 0, it is evaluated as the "Dew point alarm" status. Reception of the object value 1 signifies "No dew point alarm".
- Object value = 1: On the reception of the object value 1, it is evaluated as the "Dew point alarm" status. Reception of the object value 0 signifies "No dew point alarm".



Note: This parameter is only visible if Dew point status input "Via group object" is activated.

13.2.43 Application Parameters - Fill level sensor input

| | |
|---------|--|
| Options | Deactivated Via physical device input Via group object |
|---------|--|

This parameter is used to inform the device whether it is to include the level in a condensation tray (Alarm/No alarm) in the control.

- Deactivated: If Deactivated has been selected, the level alarm is not taken into account by the controller.
- Via physical device input: If this option is selected, the controller checks which of the physical device inputs has been parameterized for a fill level sensor. The status of the fill level sensor connected to this input is included in the control. The message: Configure in 'Inputs' parameter window appears. Only device inputs that have been parameterized as a fill level sensor are detected as such. If no input has been parameterized as a fill level sensor, the function is considered deactivated. If several inputs have been parameterized as a fill level sensor, there is a logical OR link between these inputs. As soon as one of the contacts signals the status "Fill level reached", the controller evaluates the status as "Fill level alarm". Conversely, if none of the inputs signals the status "Fill level reached", the controller evaluates the status as "No fill level alarm".
- Via group object: The fill level alarm is received via a group object. The dependent Fill level alarm group object appears. The fill level alarm must be connected to the group object using this object. In addition, the dependent Fill level reached when parameter is enabled:

13.2.44 Application Parameters - Fill level reached when

| | |
|---------|--------------------------------------|
| Options | Object value = 0 Object value = 1 |
|---------|--------------------------------------|

This parameter is used to select which object value is to be considered fill level reached on reception. The controller reacts to the reception of the "Fill level alarm" status with the shutdown of the cooling and a changeover to Building Protection mode. This mode applies until the fill level alarm is cleared. However, a change to the heating mode (if possible) is allowed at any time. Here the device continues to operate normally because the fill level only relates to the cooling. A fill level sensor is used, e.g., to monitor a condensation tray fitted under a fan coil unit. Because moisture often arises directly on the fins during cooling, a tray is installed underneath to collect the moisture. These trays normally have an outlet to drain off the condensation. To monitor whether the outlet is functioning, fill level sensors are

installed. These sensors signal if a specific level is exceeded. To prevent further filling and the overflow of the condensation tray, cooling is deactivated in this situation.



Note: This parameter is only visible if Fill level reach when "Via group object" is activated.

13.2.45 Application Parameters - Temperature input

| | |
|---------|---|
| Options | Via physical device input + Int measure Via group object Via physical device input + Int measure + GO |
|---------|---|

This parameter specifies how the integrated controller receives the actual temperature. Because the device cannot operate without information on the actual temperature, this parameter cannot be deactivated. Only device inputs that have been parameterized as a temperature sensor are detected as such. If several inputs are parameterized as a temperature sensor, a mean value is formed from the values measured and this mean value is used as the actual temperature value. If an option with the physical device inputs has been selected as the temperature input, it is to be ensured that a temperature sensor is also connected to one of the inputs. Otherwise, the device changes to a fault mode. With the aid of the parameters on the type of temperature input and the weighting of the different inputs, it is possible to represent even more complex room situations. The temperature values can flow into the calculation with different weightings.

- Via physical device input + Int measure: If this option is selected, the controller checks which of the physical device inputs has been parameterized for a temperature sensor. The value measured using this sensor is taken into account in the control with the internal measurement. The message: Configure in 'Inputs' parameter window appears.
- Via group object: If this option is selected, the actual temperature is received via group object(s). The temperature can then be measured in a different device and transmitted to the device via the bus. The dependent parameter Number of temperature input objects is enabled.
- Via physical device input + Int measure + GO: If this option is selected, the controller checks which of the physical device inputs have been parameterized as a temperature sensor. Temperature values can also be received via the bus. The values measured on the inputs and received via the bus are weighted. The message: Configure in 'Inputs' parameter window appears. The dependent parameters Number of temperature input objects, Internal measurement weighting and Weighting of external measurement 1 appear.

13.2.46 Application Parameters - Number of temperature input objects

| | |
|---------|--------|
| Options | 1 2 |
|---------|--------|

This parameter is used to specify the number of group objects that can receive temperature values via the bus. Using these two objects, temperature values measured using other devices can be received; these values are then used to determine the actual temperature.

- Option 1 has been selected and in the Temperature input the Via physical device input and group object option is not selected, the temperature received in the External temperature 1 group object is the actual temperature.
- Option 2 has been selected, the dependent parameters Weighting of external measurement 1 and Weighting of external measurement 2 are enabled.



Note: This parameter is visible if, in the Temperature input parameter, the Via group object or Via physical device input + Int measure + group object option has been selected.

13.2.47 Application Parameters - Physical device input + Internal measurement weighting

| | |
|---------|-----------|
| Options | 0 to 100% |
|---------|-----------|

This value specifies the weighting with which the internal measurement is to flow into the calculation of the actual temperature.



Note: This parameter is visible if, in the Temperature input parameter, the Via physical device input + Int measure or Via physical device input + Int measure + group object option has been selected.

13.2.48 Application Parameters - Weighting of external measurement 1

| | |
|---------|-----------|
| Options | 0 to 100% |
|---------|-----------|

This value specifies the weighting with which the external measurement 1 is to flow into the calculation of the actual temperature.



Note: This parameter is only visible if both the following cases apply:

- In the Temperature input parameter, the Via group object option has been selected.
- In the Temperature input parameter, the Via physical device input + Int measure + GO option has been selected and in the Number of temperature input objects parameter, the 2 option has been selected.

13.2.49 Application Parameters - Weighting of external measurement 2

| | |
|---------|-----------|
| Options | 0 to 100% |
|---------|-----------|

This value specifies the weighting with which the external measurement 2 is to flow into the calculation of the actual temperature. If the sum of the total weighting values is greater than 100 %, the ratio of the values is formed, and the result then scaled back to 100 %.

Example 1:

Value 1 = 20 %

Value 2 = 80 %

Value 2 is taken into account with four times the weighting of value 1.

Expressed in figures:

Value 1: 20 °C; weighting 20 %

Value 2: 25 °C; weighting 80 %

$((20 \text{ °C} \times 0.2) + (25 \text{ °C} \times 0.8)) / (0.8 + 0.2) = 24 \text{ °C}$

Example 2:

3 values: If 50 % is entered as the weighting for all three values, all values have the same weighting and a mean value is simply formed from the three values.

Example 3:

2 values: The weighting 80 % applies to value 1 and the weighting 40 % to value 2, value 1 is therefore taken into account in the calculation with twice the weighting of value 2.

Expressed in figures:

Value 1: 21 °C; weighting 80 %

Value 2: 24 °C; weighting 40 %

$$((21 \text{ °C} \times 0.8) + (24 \text{ °C} \times 0.4)) / (0.8 + 0.4) = 22 \text{ °C}$$



Note: This parameter is only visible if in the Number of temperature input objects parameter, the 2 option has been selected.

13.2.50 Application Parameters - Occupancy presence detection logic

| | |
|---------|------------------------|
| Options | Activate Deactivate |
|---------|------------------------|

This is to activate or deactivate the occupancy presence detection logic function. Upon activating occupancy presence detection logic, default reporting of the room occupancy status will be transmitted into bus network via group object "Room occupancy status". Occupancy presence detection logic function group object "Room occupancy status" will as well affect the status of "Power energization". When "Room occupancy status" = 0, it will switch off "Power energization"

When Occupancy presence detection logic is activated, logic function will use and combine the status of 2 x binary input. Binary input E1 will be for Door contact, Binary input E2 will for presence detector (No link to existing presence detector function).



NOTE: When Occupancy presence detection logic function is activated, pending Input a and Input b configuration for receiving of signal, if "via physical input" is selected, parameter for input a and input b will be predetermine

Scenario A

At any one time, when E2 detect input signal (room occupancy status, 1 bit=1, guest present), operating mode will be change to comfort mode until new trigger from E1 (binary input A, 1-bit=0: door open or 1-bit=1: door close) is receive.

Scenario B

Caldion will be in ECO mode when there is no occupancy. When door is open, E1 input (binary input A) signal will be "1-bit=0". Caldion will remain at ECO mode for the next 10 min (adjustable in ETS) pending input from E2 input (binary input B). If within 10 min, E2 input (binary input B) detect a trigger "1-bit=1", operating mode will change from ECO mode to comfort mode (Room occupancy status, 1-bit=1, guest present).

Scenario C

Caldion will be in ECO mode when there is no occupancy. When door is open, E1 input (binary input A) signal will be "1-bit=0". Caldion will remain at ECO mode for the next 10 min (adjustable in ETS) pending input from E2 input (binary input B). After 10 min, E2 input (binary input B) did not detect a trigger "1-bit=0", operating mode will change from ECO mode to Standby mode (Room occupancy status, 1-bit=0, guest not present)

Scenario D

Caldion will be in standby mode when the door is close, E1 input (binary input A) signal will be "1-bit=1". Caldion will remain at standby mode for the next 10 min (adjustable in ETS) pending input from E2 input (binary input B). If within 10 min, E2 input (binary input B) detect a trigger "1-bit=1", operating mode will change from standby mode to comfort mode (Room occupancy status, 1-bit=1, guest present).

Scenario E

Caldion will be in standby mode when the door is close, E1 input (binary input A) signal will be "1-bit=1". Caldion will remain at standby mode for the next 10 min (adjustable in ETS) pending input from E2 input (binary input B). After 10 min, E2 input (binary input B) did not detect a trigger "1-bit=0", operating mode will remain at standby mode (Room occupancy status, 1-bit=0, guest not present)

Scenario F

Caldion will be in standby mode when the door is close, E1 input (binary input A) signal will be "1-bit=1". Caldion will remain at standby mode for the next 60 min (adjustable in ETS) pending input from E2 input (binary input B). If within 60 min, E2 input (binary input B) detect a trigger "1-bit=1", operating mode will change from standby mode to comfort mode (Room occupancy status, 1-bit=1, guest present).

Scenario G

Caldion will be in standby mode when the door is close, E1 input (binary input A) signal will be "1-bit=1". Caldion will remain at standby mode for the next 60 min (adjustable in ETS) pending input from E2 input (binary input B). After 60 min, E2 input (binary input B) did not detect a trigger "1-bit=0", operating mode will change from standby mode to ECO mode (Room occupancy status, 1-bit=0, guest not present)

Scenario H

Caldion will be in standby mode when the door is open and remain open, E1 input (binary input A) signal will be "1-bit=0". Caldion will remain at standby mode for the next 10 min (adjustable in ETS) pending input from E2 input (binary input B). After 10 min, E2 input (binary input B) did not detect a trigger "1-bit=0" and door remain open, E1 input (binary input A) signal will be "1-bit=0". Caldion will remain at standby mode

for another next 10 min (adjustable in ETS). After the second 10 min, if E2 input (binary input B) still did not detect a trigger "1-bit=0" and door still remain open, E1 input (binary input A) signal will be "1-bit=0". Operating mode will change form standby mode to ECO mode (room occupancy status, 1-bit=0, guest not present, door remain as open).

Scenario I

Caldion will be in ECO mode when the door is open and remain open after 10 min + 10 min, E1 input (binary input A) signal will be "1-bit=0". Caldion will remain at ECO mode is there is no input from E1 input and E2 input. If E2 input (binary input B) detect a trigger "1-bit=1 ", operating mode will change from ECO mode to comfort mode (Room occupancy status, 1-bit=1, guest present) else when the door is close, E1 input (binary input A) signal will be "1-bit=1". Caldion will remain at ECO mode for the next 10 min (adjustable in ETS) and pending input from E2 input (binary input B). If within 10 min, E2 input (binary input B) detect a trigger "1-bit=1 ", operating mode will change from ECO mode to comfort mode (Room occupancy status, 1-bit=1, guest present, door close). Else after 10 min, Caldion will change operating mode from ECO to Standby mode, Caldion will remain at standby mode for the next 60 min (adjustable in ETS) pending input from E2 input (binary input B). After 60 min, E2 input (binary input B) did not detect a trigger "1-bit=0", operating mode will change from standby mode to ECO mode (Room occupancy status, 1-bit=0, guest not present)

13.2.51 Application Parameters - Occupancy presence detection logic flow chart

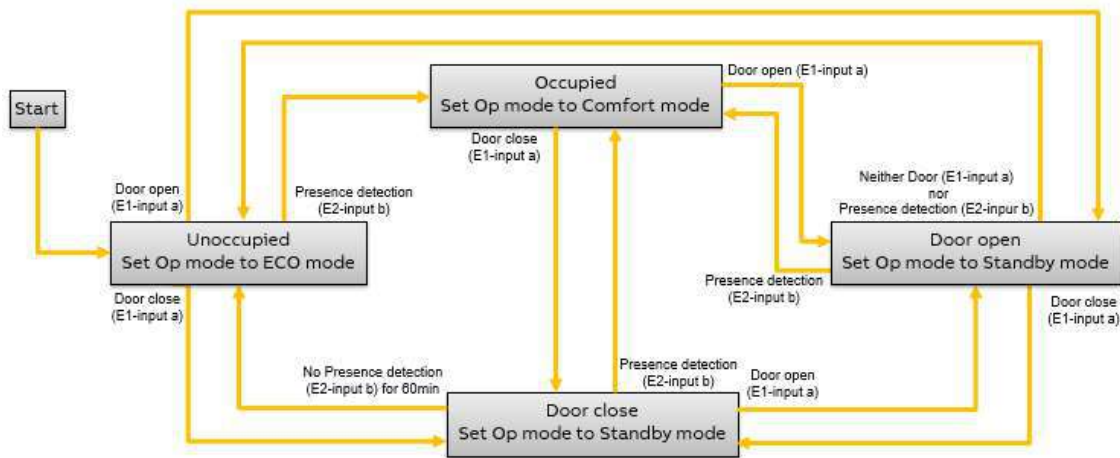

13.2.52 Application Parameters - To include physical output VB/RO for power energization

| | |
|---------|------------------------|
| Options | Activate Deactivate |
|---------|------------------------|

This is to activate or deactivate the physical output VB/RO for power energization function. Power energization trigger is link to "Door contact detection" and "Room occupancy status"

Physical output VB/RO for power energization will turn be on when
 - "Door contact detection" via physical device-Input a detect a "On" input signal or-
 "Door contact detection" via group object receive a "On" signal

Off signal from physical device-Input A or group object will have no effect on power energization function.

Physical output VB/RO for power energization will turn be off when
 - "Room occupancy status" = 0

Note: Physical output VB/RO for power energization function would only be available when VB/RO is neither used for controlling of valve or electric heater (output via Valve A).

13.2.53 Fan only mode

| | |
|---------|------------------------|
| Options | Activate Deactivate |
|---------|------------------------|

This is to set whether does device have fan only mode. If fan only mode is activated, fan only mode can also be activated or deactivated via group object.

13.2.54 Application Parameters - Door contact detection

| | |
|---------|---|
| Options | Via physical device-Input-A Via group object |
|---------|---|

This is to set how is the Door contact detection is trigger, by physical input contact signal from input A or by group address trigger from bus line.

13.2.55 Application Parameters - Door open when

| | |
|---------|--------------------------------------|
| Options | Object value = 0 Object value = 1 |
|---------|--------------------------------------|

This is to set the object value of door open when door open status is updated via group object.

13.2.56 Application Parameters - Duration for first checking of presence

| | |
|---------|----------------------|
| Options | 00:00:10 to 01:00:00 |
|---------|----------------------|

This is to set the monitor time for first checking of presence when there is a change in E1 input (binary input A) status

13.2.57 Application Parameters - Duration for second checking of presence before activating ECO mode

| | |
|---------|----------------------|
| Options | 00:00:10 to 01:20:00 |
|---------|----------------------|

This is to set the monitor time for second checking of presence after the lapse of first checking of presence duration and when E1 input (binary input A: 1-bit = 1), when there is no detection of people presence. E2 input (Binary input B) (1-bit = 0) operating mode will change from standby mode to ECO mode (no presence of people).

13.2.58 Application Parameters - Presence detection

| | |
|---------|---|
| Options | Via physical device-Input-B Via group object |
|---------|---|

This is to set how is the presence detection is trigger, by physical input contact signal from input B or by group address trigger from busline.

13.2.59 Application Parameters - Presence detection when

| | |
|---------|--------------------------------------|
| Options | Object value = 0 Object value = 1 |
|---------|--------------------------------------|

This is to set the object value of presence detection when presence detection status is updated via group object.

13.2.60 Device Function - Heating/Cooling/Off mode after 230V recovery

| | |
|---------|---|
| Options | As before 230V failure Heating Cooling Off |
|---------|---|

This parameter is used to specify the mode (heating / cooling / off) in which the device is to be after 230V recovery.

- As before 230V failure: The device is in the same mode as before 230V failure.
- Heating: The device is in the heating mode after 230V recovery.
- Cooling: The device is in the cooling mode after 230V recovery.
- Off: The device is in off mode after 230V recovery.



Note: If the device is operating in fan mode prior to power lost, default it will return to off mode when the power is recover.

13.2.61 Device Function - Control value after 230V recovery

| | |
|---------|----------------------------------|
| Options | As before 230V failure Select |
|---------|----------------------------------|

This parameter specifies which control value is to apply after 230V recovery until the controller has calculated a new control value. The reaction parameterized here also applies during the sending and switching delay. After 230V recovery it can take up to 2 seconds until the device has started and the outputs can be switched/controlled again.

- As before 230V failure: The same control value as before the 230V failure applies.
- Select: A control value can be specified. This control value applies until a new control value is calculated/a new control value is received via the bus. The Control value dependent parameter is displayed

13.2.62 Device Function - Control value

| | |
|---------|-----------|
| Options | 0 to 100% |
|---------|-----------|

This parameter is used to specify the control value that is to apply after 230V recovery until a new control value is received.

13.2.63 Device Function - Reaction on 230V recovery fan output

| | |
|---------|---|
| Options | Unchanged Applies control value 1 2 3 |
|---------|---|

This parameter is used to specify the fan speed that is to apply after 230V recovery.

- Unchanged: The same fan speed as before/during the 230V failure applies. The status of the automatic mode also remains unchanged. The fan follows the valve control value if the automatic mode is active.
- Applies control value: The speed is dependent on the valve control value. The automatic mode is active. If the automatic mode was deactivated before the download, it is activated.
- 1: The fan runs with speed 1 in the manual mode.
- 2: The fan runs with speed 2 in the manual mode.
- 3: The fan runs with speed 3 in the manual mode.

13.2.64 Device Function - Reaction on 230V recovery relay output

| | |
|---------|------------------------|
| Options | Unchanged On Off |
|---------|------------------------|

The reaction of the relay output after 230V recovery is specified using this parameter

- Unchanged: The relay remains in its actual position after 230V recovery.
- On: The relay is switched on after 230V recovery.
- Off: The relay is switched off after 230V recovery



NOTE: Applicable to 0~10V version only

13.2.65 Device Function - Heating/cooling mode after ETS download/reset

| | |
|---------|--------------------|
| Options | Heating Cooling |
|---------|--------------------|

Operating mode of heating or cooling mode is specified using this parameter after ETS download/reset.

13.2.66 Device Function - Control value after ETS download

| | |
|---------|---------------------|
| Options | Unchanged Select |
|---------|---------------------|

This parameter specifies which control value is to apply after a download until the controller has calculated a new control value. The value specified here applies until a new control value has been received via the bus.

- Unchanged: The same control value as before the download applies.
- Select: A control value can be specified. This control value then applies until a new

control value is calculated/a new control value is received via the bus. The Control value dependent parameter is displayed.

13.2.67 Device Function - Control value

| | |
|---------|-----------|
| Options | 0 to 100% |
|---------|-----------|

This parameter is used to specify the control value that is to apply after ETS download until a new control value is received.

13.2.68 Device Function - Fan output after ETS download

| | |
|---------|---|
| Options | Unchanged Applies control value 1 2 3 |
|---------|---|

This parameter is used to specify the fan speed that is to apply after a ETS download.

- Unchanged: The same fan speed as before the download. The status of the automatic mode also remains unchanged. The fan follows the valve control value if the automatic mode is active.
- Applies control value: The speed is dependent on the valve control value; the automatic mode is active. If the automatic mode was deactivated before the download, it is activated.
- 1: The fan runs with speed 1 in the manual mode.
- 2: The fan runs with speed 2 in the manual mode.
- 3: The fan runs with speed 3 in the manual mode

13.2.69 Device Function - Relay output after ETS download

| | |
|---------|------------------------|
| Options | Unchanged On Off |
|---------|------------------------|

The reaction of the relay output after ETS download is specified using this parameter

- Unchanged: The relay remains in its actual position after ETS download.
- On: The relay is switched on after ETS download.
- Off: The relay is switched off after ETS download



NOTE: Applicable to 0~10V version only.

13.2.70 Temperature controller

General settings for the temperature controller are made in this window. These settings affect above all the basic load, the sending of control values for the inactive operating mode and the behavior on sending the actual room temperature (actual temperature).

13.2.71 Temperature controller – Minimum control value for basic load >
 0

| | |
|---------|--------------------------------------|
| Options | Activate via object Always active |
|---------|--------------------------------------|

This parameter is used to specify whether the basic load for the individual heating and cooling stages is to be always active or whether it is to be possible to activate or deactivate it via a group object. The settings for the basic load can be specified independently for each stage. This setting is specified in the Temperature controller - Basic-stage heating, Temperature controller - Additional-stage heating, Temperature controller - Basic-stage cooling, Temperature controller - Additional-stage cooling parameter window. Here the minimum control value for the basic load that is not allowed to be dropped below is specified. This value can only be specified for the PI control types. The basic load is always activated for all stages, but only applies to the currently active heating or cooling operating mode. A possible application for the basic load is, e.g., floor heating in which a specific control value must not be dropped below to protect the installation.

- **Activate via object:** On the selection of this option, the Min. control value (basic load) function can be activated (1) or deactivated (0) via the Activate minimum control value (basic load) group object. If it is activated, then the heating medium is always pumped through the system with at least the minimum control value. If it is deactivated, the control value can be reduced to zero by the controller. The dependent Activate minimum control value (basic load) group object is enabled.
- **Always active:** On the selection of this option, the basic load is always active.

13.2.72 Temperature controller – Basic load active when controller off

| | |
|---------|-----------|
| Options | No Yes |
|---------|-----------|

This parameter is used to specify whether the basic load is to be active if the controller has been switched off via the Request On/Off (master) group object.

- **No:** The basic load is also switched off if the controller is switched off.
- **Yes:** The basic load remains active even if the controller is switched off.

13.2.73 Temperature controller – Send inactive control values cyclically

| | |
|---------|-----------|
| Options | No Yes |
|---------|-----------|

The parameter is used to influence the behavior on sending the controller control value output. This parameter can be used to specify whether the control values for the operating mode not currently active (heating or cooling) are to be sent or not. This setting is necessary for systems that have only one control value input for heating and cooling. In this situation, both output objects for the control value (Status Control value Basic-stage heating and Status Control value Basic-stage cooling) must be linked to the same input object. The cyclic sending of both control values in this situation means that the active and inactive value continuously overwrite each other. To prevent this action from arising, the cyclic sending of the inactive control value can be inhibited.

The following example makes the behavior clear:

- **Active operating mode: Heating**

- Heating control value: 50 %
 - Cooling control value: 0 %
 - Sending cycle time: 5 minutes (for both operating modes)
 - Valve drive actuator: 2-pipe system for heating and cooling (only one control value input)
 - Sending heating control value: control value received: 50 %
 - Valve drive actuator output control value: 50 %
 - Sending cooling control value: control value received: 0 %
 - Valve drive actuator output control value: 0 %
 - No: The cyclic sending of the inactive control values is inhibited. Only the control values for the operating mode (heating or cooling) currently active are sent.
 - Yes: The cyclic sending of the inactive control values remains active. All control values are always sent corresponding to the cycle time selected.
- The cycle times for the individual control values can be set in the related parameter window (e.g. Basic-stage heating) in Extended settings in the Send control value cyclically parameter.



Note: This parameter is enabled if the controller has been parameterized both for heating and for cooling. For this purpose, the Deactivated option must not be selected for the two parameters Basic-stage heating and Basic-stage cooling in the Application parameters parameter window.

13.2.74 Temperature controller – Send current room temperature cyclically (0 = cyclical sending deactivated)

| | |
|---------|--------------|
| Options | 0 to 255 Min |
|---------|--------------|

This parameter is used to specify the cycle with which the room temperature determined is to be sent via the Actual temperature group object. This temperature is the room temperature calculated from the different values.

13.2.75 Temperature controller – Temperature change for sending current room temperature

| | |
|---------|------------|
| Options | 0.1 to 10K |
|---------|------------|

This parameter is used to specify the level of temperature change before new room temperature value is resend via the Actual temperature group object. If the temperature changes by the value parameterized here, the new value is sent on the bus. The actual room temperature is made up of various values, depending on the selection in the Temperature input parameter Application parameters parameter window). The values measured via the physical device inputs and received via group objects (External temperature 1 & External temperature 2) are used in the calculation. This value is the actual room temperature (actual temperature).

13.2.76 Temperature controller – Basic-stage heating control value type

| | |
|---------|--|
| Options | 2-point 1 bit (On/Off) 2-point 1 byte (0/100 %) PI continuous (0...100 %) PI PWM (On/Off) PI continuous (0...100 %) for Fan Coil |
|---------|--|

This parameter is used to specify the control and control value type for the basic-stage heating. The standard value for the parameter is dependent on the selection in

the Basic-stage heating and Actuate basic-stage heating via parameters (Application parameters parameter window). On the selection of one of the physical device outputs for the actuation of the basic-stage heating or on output via KNX group object, the controller has a fixed pre-configuration that cannot be changed. The pre-configured controller type is dependent here on the option selected in the Basic-stage heating parameter.

The only exception is on the selection of Free configuration. In this situation, everything can be selected and set freely.

The following table shows the dependencies:

| Option selected: Basic-stage heating | Preconfigured controller type: type of heating control value | Controller type can be changed |
|---|--|--------------------------------|
| Convactor (e.g. radiator) | PI continuous (0...100 %) | No |
| Area (e.g. floor heating) | PI continuous (0...100 %) | No |
| Electric heater (in room) | 2-point 1 bit (On/Off) | No |
| Free configuration | PI continuous (0...100 %) | Yes |
| Fan coil unit: electric heater (in fan coil unit) | 2-point 1 bit (On/Off) | No |
| Fan coil unit: Water heating coil | PI continuous (0...100 %) | No |

The differences between the individual controller types are explained in the following:

- 2-point 1 bit (On/Off): 2-point control is the simplest form of control. The controller switches on if the room temperature has dropped below a specific level (temperature setpoint minus hysteresis) and off as soon as a specific value (temperature setpoint plus hysteresis) is exceeded. The switch-on and switch-off commands are sent as 1-bit commands. The dependent Status Control value Basic-stage heating group object is enabled as a 1-bit group object.
- 2-point 1 byte (0/100 %): This is also two-point control as above. The difference is that switch on and switch-off commands are sent as 1-byte values (0 %/100 %). The dependent Status Control value Basic-stage heating group object is enabled as a 1-byte group object.
- PI continuous (0...100 %): The PI controller adjusts its output value, between 0 % and 100 %, to the difference between the actual value and setpoint and permits exact regulation of the room temperature to the setpoint. It outputs the control value on the bus as a 1-byte value (0...100 %). To reduce the bus load, the control value is only sent if it has changed by a previously specified percentage in relation to the value sent last. In addition, the control value can be sent cyclically. The dependent Status Control value Basic-stage heating group object is enabled as a 1-byte group object.
- PI PWM (On/Off): This is also a PI controller. The output is as a 1-bit command. For this purpose the control value calculated is implemented using a pulse-pause ratio. The dependent Status Control value Basic-stage heating group object is

enabled as a 1-bit group object.

- PI continuous (0...100 %) for Fan Coil: The fan coil controller operates like the PI continuous controller. In addition, the fan output is also actuated in the automatic mode corresponding to the control value for the basic-stage heating. The dependent Status Control value Basic-stage heating group object is enabled as a 1-byte group object.

13.2.77 Temperature controller – 2-point 1 bit (On/Off), 2-point 1 byte (0/100%)

The following parameters are enabled if the 2-point 1 bit (On/Off) or 2-point 1 byte (0/100%) option has been selected in the Basic-stage heating control value type parameter.

13.2.78 Temperature controller – Use control value for fan automation

| | |
|---------|-----------|
| Options | No Yes |
|---------|-----------|

This parameter can be used to specify whether the control value for this stage is also to be used as the control value for the fan automation. If the related stage has a free configuration, the device does not know whether the stage actuated is a fan coil unit or not. However, because the fan automation only makes sense for the fan coil unit stages, an assignment must be made here. If a free configuration is selected for all 4 control stages and none of the stages is also parameterized for fan automation, the fan automation remains without function.

- No: The control value is not used for the fan automation.
- Yes: The control value is used for the fan automation. If this stage is active and the fan is in the automatic mode, the control value is also used as a control value to actuate the fan.



Note: This parameter is only visible if the Free configuration option has been selected for the Basic-stage heating parameter in the Application parameters parameter window.

13.2.79 Temperature controller – Extended settings

| | |
|---------|-----------|
| Options | No Yes |
|---------|-----------|

Extended settings can be enabled using this parameter. This parameter is displayed on the selection of the Yes option.

13.2.80 Temperature controller – Control value direction

| | |
|---------|--------------------|
| Options | Normal Inverted |
|---------|--------------------|

This parameter is used to specify the control value direction if it is only output via a group object. The setting is used to actuate NC (normally closed) or NO (normally opened) valves. If one of the physical device outputs is used to output the control value, this parameter is not displayed because this setting is then made in the related output stage.

- Normal: The control value is output normally. Control value On/100 % => telegram value On/100 %, Control value Off/0 % => telegram value Off/0 %
- Inverted: The control value is output inverted. Control value On/100% => telegram Off/0 %, Control value Off/0 % => telegram On/100%



Note: This parameter is only visible if the Via group object option has been selected for the Actuate basic-stage heating via parameter in the Application parameters parameter window and Extended settings parameter is selected as Yes

13.2.81 Temperature controller – Hysteresis

| | |
|---------|--------------|
| Options | 0.3 to 25.5K |
|---------|--------------|

This parameter is used to specify the hysteresis that is to apply to the setpoint to prevent continuous switching of the controller.

- Upper switching point = setpoint + hysteresis
- Lower switching point = setpoint – hysteresis

Heating controller:

- If the actual temperature is below the lower switching point, the controller switches on.
- If the actual temperature is above the upper switching point, the controller switches off.

Cooling controller:

- If the actual temperature is below the lower switching point, the controller switches off.
- If the actual temperature is above the upper switching point, the controller switches on.



Note: This parameter is only visible if Extended settings parameter is selected as Yes

13.2.82 Temperature controller – Send control value cyclically (0 = cyclical sending disabled)

| | |
|---------|-------------|
| Options | 0 to 60 min |
|---------|-------------|

This parameter is used to specify the cycle time with which the control value is to be sent. On the selection of the value 0, cyclic sending is deactivated. If the control value is only output via a group object, this value should not be set to 0 because otherwise it will not be ensured that the actuator receives its control value. In particular, in combination with the Control value difference for sending control value parameter and the Only send cyclically option that can be selected there, the value 0 is not allowed to be selected. This configuration would mean that the control value is never output.



Note: This parameter is only visible on the selection of the 2-point 1 bit (On/Off), 2-point 1 byte (0/100%), PI continuous (0...100 %) or PI continuous (0...100 %) for Fan Coil option and Extended settings parameter is selected as Yes

13.2.83 Temperature controller – Activate temperature limitation

| | |
|---------|-----------|
| Options | No Yes |
|---------|-----------|

A controller limit temperature can be activated using this parameter. Using the limit temperature, the controller's control value for this stage can be set to 0 on reaching a parameterized temperature. In this way, exceeding (heating) or dropping below (cooling) this temperature can be prevented. An example of the usage of the limit temperature is floor heating, where exceeding a specific temperature must be prevented to protect the material of the floor.

- No: The limit temperature is deactivated.
- Yes: The limit temperature is activated. The following dependent parameters are also displayed.



Note: This parameter is only visible if Extended settings parameter is selected as Yes

13.2.84 Temperature controller – Limited temperature

| | |
|---------|-----------------|
| Options | 20 to 50 degree |
|---------|-----------------|

The value set here specifies the limit temperature that is not allowed to be exceeded (heating) or dropped below (cooling). If the temperature reaches this value, the control value is immediately set to 0. The value set here is compared with the value received via a group object or via one of the physical device inputs (depending on the option selected, in the Input for temperature limit sensor parameter).



Note: This parameter is only visible if Extended settings parameter is selected as yes and Activate temperature limitation parameter is selected as yes

13.2.85 Temperature controller – Limit temperature hysteresis

| | |
|---------|-----------|
| Options | 0.5 to 5K |
|---------|-----------|

The hysteresis on the limit temperature specifies the value by which the limit temperature must be dropped below again (heating) or exceeded (cooling) before the controller becomes active again.



Note: This parameter is only visible if Extended settings parameter is selected as yes and Activate temperature limitation parameter is selected as yes.

13.2.86 Temperature controller – Input for temperature limit sensor

| | |
|---------|--|
| Options | Via group object Via physical device input a Via physical device input b |
|---------|--|

A temperature sensor must be actually connected to the temperature input selected and the input for the sensor must have been correctly parameterized, otherwise the limit temperature function does not work. If one of the device inputs is selected here as the input for the limit temperature, this input is no longer used to acquire the room

temperature. It is therefore not possible to use the same temperature sensor for the measurement of the room temperature and for the measurement of the limit temperature.

- Via group object: The temperature value is received via a dedicated group object. The dependent Basic-stage heating limit temperature group object is enabled.
- Via physical device input x: The temperature value is acquired via a temperature sensor connected (to the selected input).



Note: This parameter is only visible if Extended settings parameter is selected as yes and Activate temperature limitation parameter is selected as yes.

13.2.87 Temperature controller – PI continuous (0...100 %), PI PWM (On/Off), PI continuous (0...100 %) for Fan Coil

The following parameters are enabled if the PI continuous (0...100 %), PI PWM (On/Off) or PI continuous (0...100 %) for Fan Coil option has been selected in the Basic-stage heating control value type parameter.

13.2.88 Temperature controller – P-proportion

| | |
|---------|-----------|
| Options | 1 to 10 K |
|---------|-----------|

The P-proportion stands for the proportional range in a control. It fluctuates around the setpoint and in a PI control is used to change the speed of the control. The smaller the value set, the faster the control reacts. However, the value should not be set too small because otherwise there may be a risk of overshoot.

The standard value depends on the option selected in the Basic-stage heating parameter in the Application parameters parameter window.



Note: This parameter is only visible if the Free configuration option has been selected for the Basic-stage heating parameter in the Application parameters parameter window

13.2.89 Temperature controller – I-proportion

| | |
|---------|--------------|
| Options | 0 to 255 min |
|---------|--------------|

The I-proportion stands for the integral time in a control. The integral proportion causes the room temperature to approach the setpoint slowly and also to reach it finally. Depending on the system type used, the integral time may need to have different values. In principle the following applies: The more sluggish the overall system, the larger the integral time is

The standard value depends on the option selected in the Basic-stage heating parameter in the Application parameters parameter window.



Note: This parameter is only visible if the Free configuration option has been selected for the Basic-stage heating parameter in the Application parameters parameter window.

13.2.90 Temperature controller – Use control value for fan automation

| | |
|---------|-----------|
| Options | No Yes |
|---------|-----------|

This parameter can be used to specify whether the control value for this stage is also to be used as the control value for the fan automation. If the related stage has a free configuration, the device does not know whether the stage actuated is a fan coil unit or not. However, because the fan automation only makes sense for the fan coil unit stages, an assignment must be made here.

If a free configuration is selected for all 4 control stages and none of the stages is also parameterized for fan automation, the fan automation remains without function.

- No: The control value is not used for the fan automation.
- Yes: The control value is used for the fan automation. If this stage is active and the fan is in the automatic mode, the control value is also used as a control value to actuate the fan.



Note: This parameter is only visible if the Free configuration option has been selected for the Basic-stage heating parameter in the Application parameters parameter window.

13.2.91 Temperature controller – Extended settings

| | |
|---------|-----------|
| Options | No Yes |
|---------|-----------|

Extended settings can be enabled using this parameter. This parameter is displayed on the selection of the Yes option.

13.2.92 Temperature controller – Control value direction

| | |
|---------|--------------------|
| Options | Normal Inverted |
|---------|--------------------|

This parameter is used to specify the control value direction if it is only output via a group object. The setting is used to actuate NC (normally closed) or NO (normally opened) valves. If one of the physical device outputs is used to output the control value, this parameter is not displayed because this setting is then made in the related output stage.

- Normal: The control value is output normally. Control value On/100 % => telegram value On/100 %, Control value Off/0 % => telegram value Off/0 %
- Inverted: The control value is output inverted. Control value On/100% => telegram Off/0 %, Control value Off/0 % => telegram On/100%



Note: This parameter is only visible if the Via group object option has been selected for the Actuate basic-stage heating via parameter in the Application parameters parameter window and Extended settings parameter is selected as Yes.

13.2.93 Temperature controller – Control value difference for sending control value

| | |
|---------|------------|
| Options | 2 % 5 % |
|---------|------------|

| | |
|--|------------------------------|
| | 10 % Only send cyclically |
|--|------------------------------|

The control values for the PI continuous controller 0...100 % are not sent after each calculation, but when there is a difference in the calculation compared to the last value sent and sending is appropriate. This value difference can be entered here.



Note: This parameter is only visible on the selection of the PI continuous (0...100 %) or PI continuous (0...100 %) for Fan Coil option.

13.2.94 Temperature controller – Send control value cyclically (0 = cyclical sending disabled)

| | |
|---------|-------------|
| Options | 0 to 60 min |
|---------|-------------|

This parameter is used to specify the cycle time with which the control value is to be sent. On the selection of the value 0, cyclic sending is deactivated. If the control value is only output via a group object, this value should not be set to 0 because otherwise it will not be ensured that the actuator receives its control value. In particular, in combination with the Control value difference for sending control value parameter and the Only send cyclically option that can be selected there, the value 0 is not allowed to be selected. This configuration would mean that the control value is never output.



Note: This parameter is only visible on the selection of the 2-point 1 bit (On/Off), 2-point 1 byte (0/100%), PI continuous (0...100 %) or PI continuous (0...100 %) for Fan Coil option and Extended settings parameter is selected as Yes.

13.2.95 Temperature controller – Heating PWM cycle

| | |
|---------|-------------|
| Options | 1 to 60 min |
|---------|-------------|

Using the value set here, the cycle time for the control value for the PWM signal calculated from the PI controller's control value is specified. Depending on the control value, the selected cycle time is divided into an On and Off signal. Therefore, a control value output of 33 % with a PWM cycle of 15 min signifies an On phase of five minutes and an Off phase of 10 min.

The value is only sent if the control value changes (from 0 to 1 or vice versa). At the start of a cycle a 1 is output and, corresponding to the control value, a 0 after the time x. If the control value is 0 %, on reaching this control value a 0 is output once. The next value is only sent if the control value changes.

Example:

Heating PWM cycle: 15 min

Control value: 33 %

| Times | Sent value |
|--------|------------|
| 0 min | 1 |
| 5 min | 0 |
| 15 min | 1 |
| 20 min | 0 |
| 30 min | 1 |

... ..

New control value: 0 %
 Times Sent value
 60 min 0
 75 min –
 90 min –

... ..
 New control value: 66 %
 Times Sent value
 120 min 1
 130 min 0
 135 min 1
 145 min 0

 Note: This parameter is only visible on the selection of the PI PWM (On/Off) option and Extended settings parameter is selected as Yes.

13.2.96 Temperature controller – Max. control value

| | |
|---------|-----------|
| Options | 1 to 100% |
|---------|-----------|

The maximum control value from the PI controller specifies the maximum value that the controller outputs. If a maximum value below 255 is selected, then this value is not exceeded even if the controller calculates a higher control value.

 Note: This parameter is only visible on the selection of Extended settings parameter is selected as Yes.

13.2.97 Temperature controller – Min. control value (basic load)

| | |
|---------|-----------|
| Options | 0 to 100% |
|---------|-----------|

The minimum control value from the PI controller specifies the minimum value that the controller outputs. If a minimum value greater than zero is selected, then this value is not dropped below even if the controller calculates a lower control value. This parameter is used to set a basic load, e.g. for the operation of floor heating. Even if the controller calculates the control value zero, heating medium flows through the floor heating to prevent the floor from cooling down completely. In the Temperature controller parameter window, it can be set whether this basic load is to be active permanently or is to be switched via the Basic load group object. In addition, it can be set here whether the basic load is also to be active if the controller is switched off.

 Note: This parameter is only visible on the selection of Extended settings parameter is selected as Yes.

13.2.98 Temperature controller – Activate temperature limitation

| | |
|---------|-----------|
| Options | No Yes |
|---------|-----------|

A controller limit temperature can be activated using this parameter. Using the limit temperature, the controller's control value for this stage can be set to 0 on reaching a parameterized temperature. In this way, exceeding (heating) or dropping below

(cooling) this temperature can be prevented. An example of the usage of the limit temperature is floor heating, where exceeding a specific temperature must be prevented to protect the material of the floor.

- No: The limit temperature is deactivated.
- Yes: The limit temperature is activated. The following dependent parameters are also displayed.



Note: This parameter is only visible if Extended settings parameter is selected as Yes.

13.2.99 Temperature controller – Limited temperature

| | |
|---------|-----------------|
| Options | 20 to 50 degree |
|---------|-----------------|

The value set here specifies the limit temperature that is not allowed to be exceeded (heating) or dropped below (cooling). If the temperature reaches this value, the control value is immediately set to 0. The value set here is compared with the value received via a group object or via one of the physical device inputs (depending on the option selected, in the Input for temperature limit sensor parameter).



Note: This parameter is only visible if Extended settings parameter is selected as yes and Activate temperature limitation parameter is selected as yes.

13.2.100 Temperature controller – Limit temperature hysteresis

| | |
|---------|-----------|
| Options | 0.5 to 5K |
|---------|-----------|

The hysteresis on the limit temperature specifies the value by which the limit temperature must be dropped below again (heating) or exceeded (cooling) before the controller becomes active again.



Note: This parameter is only visible if Extended settings parameter is selected as yes and Activate temperature limitation parameter is selected as yes.

13.2.101 Temperature controller – I-proportion on temperature limitation

| | |
|---------|-----------------|
| Options | Freeze Reset |
|---------|-----------------|

This parameter decides what is to happen to the I-proportion on reaching the limit temperature.

- Freeze: The I-proportion is frozen at the actual value. As soon as the controller is active again, it continues to operate with the same I-proportion as before reaching the limit.
- Reset: The I-proportion is reset to 0. Once the controller becomes active again, the I-proportion starts at 0.



Note: This parameter is only visible if Extended settings parameter is selected as Yes.

13.2.102 Temperature controller – Input for temperature limit sensor

| | |
|---------|--|
| Options | Via group object Via physical device input a Via physical device input b |
|---------|--|

A temperature sensor must be actually connected to the temperature input selected and the input for the sensor must have been correctly parameterized, otherwise the limit temperature function does not work. If one of the device inputs is selected here as the input for the limit temperature, this input is no longer used to acquire the room temperature. It is therefore not possible to use the same temperature sensor for the measurement of the room temperature and for the measurement of the limit temperature.

- Via group object: The temperature value is received via a dedicated group object. The dependent Basic-stage heating limit temperature group object is enabled.
- Via physical device input x: The temperature value is acquired via a temperature sensor connected (to the selected input).



Note: This parameter is only visible if Extended settings parameter is selected as yes and Activate temperature limitation parameter is selected as yes.

13.2.103 Temperature controller – Additional-stage heating

This window is only visible if the Deactivated option has not been selected in the Additional-stage heating parameter in the Application parameters parameter window. The additional-stage heating of the temperature controller is parameterized in this window. The settings for the control type, limitation of the control range, the behavior on sending the control value and the limit temperature are made. The additional stage is used as a boost for the basic stage. If there are large deviations between the actual and setpoint temperature, the additional stage is activated to accelerate reaching the setpoint temperature.

13.2.104 Temperature controller – Additional-stage heating control value type

| | |
|---------|--|
| Options | 2-point 1 bit (On/Off) 2-point 1 byte (0/100 %) PI continuous (0...100 %) PI PWM (On/Off) PI continuous (0...100 %) for Fan Coil |
|---------|--|

This parameter is used to specify the control and control value type for the additional-stage heating. The standard value for the parameter is dependent on the selection in the additional-stage heating and Actuate additional-stage heating via parameters (Application parameters parameter window). On the selection of one of the physical device outputs for the actuation of the additional-stage heating or on output via KNX group object, the controller has a fixed pre-configuration that cannot be changed. The pre-configured controller type is dependent here on the option selected in the additional-stage heating parameter.

The only exception is on the selection of Free configuration. In this situation, everything can be selected and set freely.

The following table shows the dependencies:

| | | |
|---|--|--------------------------------|
| Option selected: Basic-stage heating | Preconfigured controller type: type of heating control value | Controller type can be changed |
| Convactor (e.g. radiator) | PI continuous (0...100 %) | No |
| Area (e.g. floor heating) | PI continuous (0...100 %) | No |
| Electric heater (in room) | 2-point 1 bit (On/Off) | No |
| Free configuration | PI continuous (0...100 %) | Yes |
| Fan coil unit: electric heater (in fan coil unit) | 2-point 1 bit (On/Off) | No |
| Fan coil unit: Water heating coil | PI continuous (0...100 %) | No |

The differences between the individual controller types are explained in the following:

- 2-point 1 bit (On/Off): 2-point control is the simplest form of control. The controller switches on if the room temperature has dropped below a specific level (temperature setpoint minus hysteresis) and off as soon as a specific value (temperature setpoint plus hysteresis) is exceeded. The switch-on and switch-off commands are sent as 1-bit commands. The dependent Status Control value Basic-stage heating group object is enabled as a 1-bit group object.
- 2-point 1 byte (0/100 %): This is also two-point control as above. The difference is that switch on and switch-off commands are sent as 1-byte values (0 %/100 %). The dependent Status Control value Basic-stage heating group object is enabled as a 1-byte group object.
- PI continuous (0...100 %): The PI controller adjusts its output value, between 0 % and 100 %, to the difference between the actual value and setpoint and permits exact regulation of the room temperature to the setpoint. It outputs the control value on the bus as a 1-byte value (0...100 %). To reduce the bus load, the control value is only sent if it has changed by a previously specified percentage in relation to the value sent last. In addition, the control value can be sent cyclically. The dependent Status Control value Basic-stage heating group object is enabled as a 1-byte group object.
- PI PWM (On/Off): This is also a PI controller. The output is as a 1-bit command. For this purpose the control value calculated is implemented using a pulse-pause ratio. The dependent Status Control value Basic-stage heating group object is enabled as a 1-bit group object.
- PI continuous (0...100 %) for Fan Coil: The fan coil controller operates like the PI continuous controller. In addition, the fan output is also actuated in the automatic mode corresponding to the control value for the basic-stage heating. The dependent Status Control value Basic-stage heating group object is enabled as a 1-byte group object.

13.2.105 Temperature controller – 2-point 1 bit (On/Off), 2-point 1 byte (0/100%)

The following parameters are enabled if the 2-point 1 bit (On/Off) or 2-point 1 byte (0/100%) option has been selected in the Additional-stage heating control value type parameter

13.2.106 Temperature controller – Temperature difference from basic-stage heating

| | |
|---------|------------|
| Options | 0 to 25.5K |
|---------|------------|

The following parameters are enabled if the PI continuous (0...100 %), PI PWM (On/Off) or PI continuous (0...100 %) for Fan Coil option has been selected in the Basic-stage heating control value type parameter.

This action occurs both if the actual temperature drops below the threshold and if it is already below the threshold.

Example 1:

Temperature difference from basic-stage heating: 2 K
 Setpoint temperature: 23 °C
 Actual temperature: 19 °C
 Additional stage is active until the actual temperature reaches 21 °C.

Example 2:

Temperature difference from basic-stage heating: 2 K
 Setpoint temperature: 23 °C
 Actual temperature: 22 °C
 Additional stage is inactive as long as the actual temperature is above 21 °C

13.2.107 Temperature controller – Use control value for fan automation

| | |
|---------|-----------|
| Options | No Yes |
|---------|-----------|

This parameter can be used to specify whether the control value for this stage is also to be used as the control value for the fan automation. If the related stage has a free configuration, the device does not know whether the stage actuated is a fan coil unit or not. However, because the fan automation only makes sense for the fan coil unit stages, an assignment must be made here.

If a free configuration is selected for all 4 control stages and none of the stages is also parameterized for fan automation, the fan automation remains without function.

- No: The control value is not used for the fan automation.
- Yes: The control value is used for the fan automation. If this stage is active and the fan is in the automatic mode, the control value is also used as a control value to actuate the fan.



Note: This parameter is only visible if the Free configuration option has been selected for the Additional-stage heating parameter in the Application parameters parameter window.

13.2.108 Temperature controller – Extended settings

| | |
|---------|-----------|
| Options | No Yes |
|---------|-----------|

Extended settings can be enabled using this parameter. This parameter is displayed on the selection of the Yes option.

13.2.109 Temperature controller – Control value direction

| | |
|---------|--------------------|
| Options | Normal Inverted |
|---------|--------------------|

This parameter is used to specify the control value direction if it is only output via a group object. The setting is used to actuate NC (normally closed) or NO (normally opened) valves. If one of the physical device outputs is used to output the control value, this parameter is not displayed because this setting is then made in the related output stage.

- Normal: The control value is output normally. Control value On/100 % => telegram value On/100 %, Control value Off/0 % => telegram value Off/0 %
- Inverted: The control value is output inverted. Control value On/100% => telegram Off/0 %, Control value Off/0 % => telegram On/100%



Note: This parameter is only visible if the Via group object option has been selected for the Actuate Additional-stage heating via parameter in the Application parameters parameter window and Extended settings parameter is selected as Yes.

13.2.110 Temperature controller – Hysteresis

| | |
|---------|--------------|
| Options | 0.3 to 25.5K |
|---------|--------------|

This parameter is used to specify the hysteresis that is to apply to the setpoint to prevent continuous switching of the controller.

- Upper switching point = setpoint + hysteresis
- Lower switching point = setpoint – hysteresis

Heating controller:

- If the actual temperature is below the lower switching point, the controller switches on.
- If the actual temperature is above the upper switching point, the controller switches off.

Cooling controller:

- If the actual temperature is below the lower switching point, the controller switches off.
- If the actual temperature is above the upper switching point, the controller switches on.



Note: This parameter is only visible if Extended settings parameter is selected as Yes.

13.2.111 Temperature controller – Send control value cyclically (0 = cyclical sending disabled)

| | |
|---------|-------------|
| Options | 0 to 60 min |
|---------|-------------|

This parameter is used to specify the cycle time with which the control value is to be sent. On the selection of the value 0, cyclic sending is deactivated. If the control value is only output via a group object, this value should not be set to 0 because otherwise it will not be ensured that the actuator receives its control value. In particular, in combination with the Control value difference for sending control value parameter and the Only send cyclically option that can be selected there, the value 0 is not allowed to be selected. This configuration would mean that the control value is never output.



Note: This parameter is only visible on the selection of the 2-point 1 bit (On/Off), 2-point 1 byte (0/100%), PI continuous (0...100 %) or PI continuous (0...100 %) for Fan Coil option and Extended settings parameter is selected as Yes.

13.2.112 Temperature controller – Activate temperature limitation

| | |
|---------|-----------|
| Options | No Yes |
|---------|-----------|

A controller limit temperature can be activated using this parameter. Using the limit temperature, the controller's control value for this stage can be set to 0 on reaching a parameterized temperature. In this way, exceeding (heating) or dropping below (cooling) this temperature can be prevented. An example of the usage of the limit temperature is floor heating, where exceeding a specific temperature must be prevented to protect the material of the floor.

- No: The limit temperature is deactivated.
- Yes: The limit temperature is activated. The following dependent parameters are also displayed.



Note: This parameter is only visible if Extended settings parameter is selected as Yes

13.2.113 Temperature controller – Limited temperature

| | |
|---------|-----------------|
| Options | 20 to 50 degree |
|---------|-----------------|

The value set here specifies the limit temperature that is not allowed to be exceeded (heating) or dropped below (cooling). If the temperature reaches this value, the control value is immediately set to 0. The value set here is compared with the value received via a group object or via one of the physical device inputs (depending on the option selected, in the Input for temperature limit sensor parameter).



Note: This parameter is only visible if Extended settings parameter is selected as yes and Activate temperature limitation parameter is selected as yes

13.2.114 Temperature controller – Limit temperature hysteresis

| | |
|---------|-----------|
| Options | 0.5 to 5K |
|---------|-----------|

The hysteresis on the limit temperature specifies the value by which the limit temperature must be dropped below again (heating) or exceeded (cooling) before the controller becomes active again.



Note: This parameter is only visible if Extended settings parameter is selected as yes and Activate temperature limitation parameter is selected as yes.

13.2.115 Temperature controller – Input for temperature limit sensor

| | |
|---------|--|
| Options | Via group object Via physical device input a Via physical device input b |
|---------|--|

A temperature sensor must be actually connected to the temperature input selected and the input for the sensor must have been correctly parameterized, otherwise the limit temperature function does not work. If one of the device inputs is selected here as the input for the limit temperature, this input is no longer used to acquire the room temperature. It is therefore not possible to use the same temperature sensor for the measurement of the room temperature and for the measurement of the limit temperature.

- Via group object: The temperature value is received via a dedicated group object. The dependent Basic-stage heating limit temperature group object is enabled.
- Via physical device input x: The temperature value is acquired via a temperature sensor connected (to the selected input).



Note: This parameter is only visible if Extended settings parameter is selected as yes and Activate temperature limitation parameter is selected as yes.

13.2.116 Temperature controller – PI continuous (0...100 %), PI PWM (On/Off), PI continuous (0...100 %) for Fan Coil

The following parameters are enabled if the PI continuous (0...100 %), PI PWM (On/Off) or PI continuous (0...100 %) for Fan Coil option has been selected in the Additional-stage heating control value type parameter.

13.2.117 Temperature controller – Temperature difference from basic-stage heating

| | |
|---------|------------|
| Options | 0 to 25.5K |
|---------|------------|

The temperature difference from basic-stage heating specifies the value from which or up to which the additional-stage heating is to be active. If the actual temperature is below the setpoint temperature by the value selected here, the additional stage is active.

This action occurs both if the actual temperature drops below the threshold and if it is already below the threshold.

Example 1:
 Temperature difference from basic-stage heating: 2 K
 Setpoint temperature: 23 °C
 Actual temperature: 19 °C

Additional stage is active until the actual temperature reaches 21 °C.

Example 2:

Temperature difference from basic-stage heating: 2 K

Setpoint temperature: 23 °C

Actual temperature: 22 °C

Additional stage is inactive as long as the actual temperature is above 21 °C

13.2.118 Temperature controller – P-proportion

| | |
|---------|-----------|
| Options | 1 to 10 K |
|---------|-----------|

The P-proportion stands for the proportional range in a control. It fluctuates around the setpoint and in a PI control is used to change the speed of the control. The smaller the value set, the faster the control reacts. However, the value should not be set too small because otherwise there may be a risk of overshoot.

The standard value depends on the option selected in the Additional-stage heating parameter in the Application parameters parameter window.



Note: This parameter is only visible if the Free configuration option has been selected for the Additional-stage heating parameter in the Application parameters parameter window

13.2.119 Temperature controller – I-proportion

| | |
|---------|--------------|
| Options | 0 to 255 min |
|---------|--------------|

The I-proportion stands for the integral time in a control. The integral proportion causes the room temperature to approach the setpoint slowly and also to reach it finally. Depending on the system type used, the integral time may need to have different values. In principle the following applies: The more sluggish the overall system, the larger the integral time is

The standard value depends on the option selected in the Basic-stage heating parameter in the Application parameters parameter window.



Note: This parameter is only visible if the Free configuration option has been selected for the Basic-stage heating parameter in the Application parameters parameter window.

13.2.120 Temperature controller – Use control value for fan automation

| | |
|---------|-----------|
| Options | No Yes |
|---------|-----------|

This parameter can be used to specify whether the control value for this stage is also to be used as the control value for the fan automation. If the related stage has a free configuration, the device does not know whether the stage actuated is a fan coil unit or not. However, because the fan automation only makes sense for the fan coil unit stages, an assignment must be made here.

If a free configuration is selected for all 4 control stages and none of the stages is also parameterized for fan automation, the fan automation remains without function.

- No: The control value is not used for the fan automation.
- Yes: The control value is used for the fan automation. If this stage is active and the fan is in the automatic mode, the control value is also used as a control value to actuate the fan.



Note: This parameter is only visible if the Free configuration option has been selected for the Additional-stage heating parameter in the Application parameters parameter window.

13.2.121 Temperature controller – Extended settings

| | |
|---------|-----------|
| Options | No Yes |
|---------|-----------|

Extended settings can be enabled using this parameter. This parameter is displayed on the selection of the Yes option.

13.2.122 Temperature controller – Control value direction

| | |
|---------|--------------------|
| Options | Normal Inverted |
|---------|--------------------|

This parameter is used to specify the control value direction if it is only output via a group object. The setting is used to actuate NC (normally closed) or NO (normally opened) valves. If one of the physical device outputs is used to output the control value, this parameter is not displayed because this setting is then made in the related output stage.

- Normal: The control value is output normally. Control value On/100 % => telegram value On/100 %, Control value Off/0 % => telegram value Off/0 %
- Inverted: The control value is output inverted. Control value On/100% => telegram Off/0 %, Control value Off/0 % => telegram On/100%



Note: This parameter is only visible if the Via group object option has been selected for the Actuate additional-stage heating via parameter in the Application parameters parameter window and Extended settings parameter is selected as Yes.

13.2.123 Temperature controller – Control value difference for sending control value

| | |
|---------|--|
| Options | 2 % 5 % 10 % Only send cyclically |
|---------|--|

The control values for the PI continuous controller 0...100 % are not sent after each calculation, but when there is a difference in the calculation compared to the last value sent and sending is appropriate. This value difference can be entered here.



Note: This parameter is only visible on the selection of the PI continuous (0...100 %) or PI continuous (0...100 %) for Fan Coil option.

13.2.124 Temperature controller – Send control value cyclically (0 = cyclical sending disabled)

| | |
|---------|-------------|
| Options | 0 to 60 min |
|---------|-------------|

This parameter is used to specify the cycle time with which the control value is to be sent. On the selection of the value 0, cyclic sending is deactivated. If the control value is only output via a group object, this value should not be set to 0 because otherwise it will not be ensured that the actuator receives its control value. In particular, in combination with the Control value difference for sending control value parameter and the Only send cyclically option that can be selected there, the value 0 is not allowed to be selected. This configuration would mean that the control value is never output.



Note: This parameter is only visible on the selection of the 2-point 1 bit (On/Off), 2-point 1 byte (0/100%), PI continuous (0...100 %) or PI continuous (0...100 %) for Fan Coil option and Extended settings parameter is selected as Yes.

13.2.125 Temperature controller – Heating PWM cycle

| | |
|---------|-------------|
| Options | 1 to 60 min |
|---------|-------------|

Using the value set here, the cycle time for the control value for the PWM signal calculated from the PI controller's control value is specified. Depending on the control value, the selected cycle time is divided into an On and Off signal. Therefore, a control value output of 33 % with a PWM cycle of 15 min signifies an On phase of five minutes and an Off phase of 10 min.

The value is only sent if the control value changes (from 0 to 1 or vice versa). At the start of a cycle a 1 is output and, corresponding to the control value, a 0 after the time x. If the control value is 0 %, on reaching this control value a 0 is output once. The next value is only sent if the control value changes.

Example:

Heating PWM cycle: 15 min

Control value: 33 %

| Times | Sent value |
|--------|------------|
| 0 min | 1 |
| 5 min | 0 |
| 15 min | 1 |
| 20 min | 0 |
| 30 min | 1 |

... ..

New control value: 0 %

| Times | Sent value |
|--------|------------|
| 60 min | 0 |
| 75 min | – |
| 90 min | – |

... ..

New control value: 66 %

| Times | Sent value |
|---------|------------|
| 120 min | 1 |
| 130 min | 0 |
| 135 min | 1 |

145 min 0

... ..



Note: This parameter is only visible on the selection of the PI PWM (On/Off) option and Extended settings parameter is selected as Yes.

13.2.126 Temperature controller – Max. control value

| | |
|---------|-----------|
| Options | 1 to 100% |
|---------|-----------|

The maximum control value from the PI controller specifies the maximum value that the controller outputs. If a maximum value below 255 is selected, then this value is not exceeded even if the controller calculates a higher control value.



Note: This parameter is only visible on the selection of Extended settings parameter is selected as Yes.

13.2.127 Temperature controller – Min. control value (basic load)

| | |
|---------|-----------|
| Options | 0 to 100% |
|---------|-----------|

The minimum control value from the PI controller specifies the minimum value that the controller outputs. If a minimum value greater than zero is selected, then this value is not dropped below even if the controller calculates a lower control value. This parameter is used to set a basic load, e.g. for the operation of floor heating. Even if the controller calculates the control value zero, heating medium flows through the floor heating to prevent the floor from cooling down completely. In the Temperature controller parameter window it can be set whether this basic load is to be active permanently or is to be switched via the Basic load group object. In addition, it can be set here whether the basic load is also to be active if the controller is switched off.



Note: This parameter is only visible on the selection of Extended settings parameter is selected as Yes.

13.2.128 Temperature controller – Activate temperature limitation

| | |
|---------|-----------|
| Options | No Yes |
|---------|-----------|

A controller limit temperature can be activated using this parameter. Using the limit temperature, the controller's control value for this stage can be set to 0 on reaching a parameterized temperature. In this way, exceeding (heating) or dropping below (cooling) this temperature can be prevented. An example of the usage of the limit temperature is floor heating, where exceeding a specific temperature must be prevented to protect the material of the floor.

- No: The limit temperature is deactivated.
- Yes: The limit temperature is activated. The following dependent parameters are also displayed.



Note: This parameter is only visible if Extended settings parameter is selected as Yes.

13.2.129 Temperature controller – Limited temperature

| | |
|---------|-----------------|
| Options | 20 to 50 degree |
|---------|-----------------|

The value set here specifies the limit temperature that is not allowed to be exceeded (heating) or dropped below (cooling). If the temperature reaches this value, the control value is immediately set to 0. The value set here is compared with the value received via a group object or via one of the physical device inputs (depending on the option selected, in the Input for temperature limit sensor parameter).



Note: This parameter is only visible if Extended settings parameter is selected as yes and Activate temperature limitation parameter is selected as yes.

13.2.130 Temperature controller – Limit temperature hysteresis

| | |
|---------|-----------|
| Options | 0.5 to 5K |
|---------|-----------|

The hysteresis on the limit temperature specifies the value by which the limit temperature must be dropped below again (heating) or exceeded (cooling) before the controller becomes active again.



Note: This parameter is only visible if Extended settings parameter is selected as yes and Activate temperature limitation parameter is selected as yes.

13.2.131 Temperature controller – I-proportion on temperature limitation

| | |
|---------|-----------------|
| Options | Freeze Reset |
|---------|-----------------|

This parameter decides what is to happen to the I-proportion on reaching the limit temperature.

- Freeze: The I-proportion is frozen at the actual value. As soon as the controller is active again, it continues to operate with the same I-proportion as before reaching the limit.
- Reset: The I-proportion is reset to 0. Once the controller becomes active again, the I-proportion starts at 0.



Note: This parameter is only visible if Extended settings parameter is selected as Yes.

13.2.132 Temperature controller – Input for temperature limit sensor

| | |
|---------|--|
| Options | Via group object Via physical device input a Via physical device input b |
|---------|--|

A temperature sensor must be actually connected to the temperature input selected and the input for the sensor must have been correctly parameterized, otherwise the limit temperature function does not work. If one of the device inputs is selected here as the input for the limit temperature, this input is no longer used to acquire the room temperature. It is therefore not possible to use the same temperature sensor for the

measurement of the room temperature and for the measurement of the limit temperature.

- Via group object: The temperature value is received via a dedicated group object. The dependent Basic-stage heating limit temperature group object is enabled.
- Via physical device input x: The temperature value is acquired via a temperature sensor connected (to the selected input).



Note: This parameter is only visible if Extended settings parameter is selected as yes and Activate temperature limitation parameter is selected as yes.

13.2.133 Temperature controller – Basic-stage cooling

This window is only visible if the Deactivated option has not been selected in the Basic-stage cooling parameter in the Application parameters parameter window. The basic-stage cooling of the temperature controller is parameterized in this window. The settings for the control type, limitation of the control range, the behavior on sending the control value and the limit temperature are made.

13.2.134 Temperature controller – Basic-stage cooling control value type

| | |
|---------|--|
| Options | 2-point 1 bit (On/Off) 2-point 1 byte (0/100 %) PI continuous (0...100 %) PI PWM (On/Off) PI continuous (0...100 %) for Fan Coil |
|---------|--|

This parameter is used to specify the control and control value type for the basic-stage cooling. The standard value for the parameter is dependent on the selection in the Basic-stage cooling and Actuate basic-stage cooling via parameters (Application parameters parameter window). On the selection of one of the physical device outputs for the actuation of the basic-stage cooling, the controller has a fixed pre-configuration that cannot be changed. The pre-configured controller type is dependent here on the option selected in the Basic-stage cooling parameter. The only exception is on the selection of Free configuration. In this situation, everything can be selected and set freely.

The following table shows the dependencies:

| Option selected: Basic-stage Cooling | Preconfigured controller type: type of cooling control value | Controller type can be changed |
|--------------------------------------|--|--------------------------------|
| Area cooling (e.g. cooling ceiling) | PI continuous (0...100 %) | No |
| Free configuration | PI continuous (0...100 %) | Yes |
| Fan coil unit: Water cooling coil | PI continuous (0...100 %) for Fan Coil | No |

The differences between the individual controller types are explained in the following:

- 2-point 1 bit (On/Off): 2-point control is the simplest form of control. The controller switches on if the room temperature has dropped below a specific level (temperature setpoint minus hysteresis) and off as soon as a specific value (temperature setpoint plus hysteresis) is exceeded. The switch-on and switch-off commands are sent as 1-bit commands. The dependent Status Control value Basic-stage heating group object is enabled as a 1-bit group object.
- 2-point 1 byte (0/100 %): This is also two-point control as above. The difference is that switch on and switch-off commands are sent as 1-byte values (0 %/100 %). The dependent Status Control value Basic-stage heating group object is enabled as a 1-byte group object.
- PI continuous (0...100 %): The PI controller adjusts its output value, between 0 % and 100 %, to the difference between the actual value and setpoint and permits exact regulation of the room temperature to the setpoint. It outputs the control value on the bus as a 1-byte value (0...100 %). To reduce the bus load, the control value is only sent if it has changed by a previously specified percentage in relation to the value sent last. In addition, the control value can be sent cyclically. The dependent Status Control value Basic-stage heating group object is enabled as a 1-byte group object.
- PI PWM (On/Off): This is also a PI controller. The output is as a 1-bit command. For this purpose, the control value calculated is implemented using a pulse-pause ratio. The dependent Status Control value Basic-stage heating group object is enabled as a 1-bit group object.
- PI continuous (0...100 %) for Fan Coil: The fan coil controller operates like the PI continuous controller. In addition, the fan output is also actuated in the automatic mode corresponding to the control value for the basic-stage heating. The dependent Status Control value Basic-stage heating group object is enabled as a 1-byte group object.

13.2.135 Temperature controller – 2-point 1 bit (On/Off), 2-point 1 byte (0/100%)

The following parameters are enabled if the 2-point 1 bit (On/Off) or 2-point 1 byte (0/100%) option has been selected in the Basic-stage cooling control value type parameter

13.2.136 Temperature controller – Use control value for fan automation

| | |
|---------|-----------|
| Options | No Yes |
|---------|-----------|

This parameter can be used to specify whether the control value for this stage is also to be used as the control value for the fan automation. If the related stage has a free configuration, the device does not know whether the stage actuated is a fan coil unit or not. However, because the fan automation only makes sense for the fan coil unit stages, an assignment must be made here.

If a free configuration is selected for all 4 control stages and none of the stages is also parameterized for fan automation, the fan automation remains without function.

- No: The control value is not used for the fan automation.
- Yes: The control value is used for the fan automation. If this stage is active and the fan is in the automatic mode, the control value is also used as a control value to actuate the fan.



Note: This parameter is only visible if the Free configuration option has been selected for the basic-stage cooling parameter in the Application parameters parameter window.

13.2.137 Temperature controller – Extended settings

| | |
|---------|-----------|
| Options | No Yes |
|---------|-----------|

Extended settings can be enabled using this parameter. This parameter is displayed on the selection of the Yes option.

13.2.138 Temperature controller – Control value direction

| | |
|---------|--------------------|
| Options | Normal Inverted |
|---------|--------------------|

This parameter is used to specify the control value direction if it is only output via a group object. The setting is used to actuate NC (normally closed) or NO (normally opened) valves. If one of the physical device outputs is used to output the control value, this parameter is not displayed because this setting is then made in the related output stage.

- Normal: The control value is output normally. Control value On/100 % => telegram value On/100 %, Control value Off/0 % => telegram value Off/0 %
- Inverted: The control value is output inverted. Control value On/100% => telegram Off/0 %, Control value Off/0 % => telegram On/100%



Note: This parameter is only visible if the Via group object option has been selected for the Actuate basic-stage cooling via parameter in the Application parameters parameter window and Extended settings parameter is selected as Yes.

13.2.139 Temperature controller – Hysteresis

This parameter is used to specify the hysteresis that is to apply to the setpoint to prevent continuous switching of the controller.

| | |
|---------|---------------|
| Options | 0.3 to 25.5 K |
|---------|---------------|

- Upper switching point = setpoint + hysteresis
- Lower switching point = setpoint – hysteresis

Heating controller:

- If the actual temperature is below the lower switching point, the controller switches on.
- If the actual temperature is above the upper switching point, the controller switches off.

Cooling controller:

- If the actual temperature is below the lower switching point, the controller switches off.
- If the actual temperature is above the upper switching point, the controller switches on.



Note: This parameter is only visible if Extended settings parameter is selected as Yes

13.2.140 Temperature controller – Send control value cyclically (0 = cyclical sending disabled)

| | |
|---------|-------------|
| Options | 0 to 60 min |
|---------|-------------|

This parameter is used to specify the cycle time with which the control value is to be sent. On the selection of the value 0, cyclic sending is deactivated. If the control value is only output via a group object, this value should not be set to 0 because otherwise it will not be ensured that the actuator receives its control value. In particular, in combination with the Control value difference for sending control value parameter and the Only send cyclically option that can be selected there, the value 0 is not allowed to be selected. This configuration would mean that the control value is never output.



Note: This parameter is only visible on the selection of the 2-point 1 bit (On/Off), 2-point 1 byte (0/100%), PI continuous (0...100 %) or PI continuous (0...100 %) for Fan Coil option and Extended settings parameter is selected as Yes.

13.2.141 Temperature controller – Activate temperature limitation

| | |
|---------|-----------|
| Options | No Yes |
|---------|-----------|

A controller limit temperature can be activated using this parameter. Using the limit temperature, the controller's control value for this stage can be set to 0 on reaching a parameterized temperature. In this way, exceeding (heating) or dropping below (cooling) this temperature can be prevented. An example of the usage of the limit temperature is a cooling ceiling, where dropping below a specific temperature must be prevented to protect the material of the ceiling against excessive cooling.

- No: The limit temperature is deactivated.
- Yes: The limit temperature is activated. The following dependent parameters are also displayed.



Note: This parameter is only visible if Extended settings parameter is selected as Yes

13.2.142 Temperature controller – Limited temperature

| | |
|---------|----------------|
| Options | 1 to 30 degree |
|---------|----------------|

The value set here specifies the limit temperature that is not allowed to be exceeded (heating) or dropped below (cooling). If the temperature reaches this value, the control value is immediately set to 0. The value set here is compared with the value received via a group object or via one of the physical device inputs (depending on the option selected, in the Input for temperature limit sensor parameter).



Note: This parameter is only visible if Extended settings parameter is selected as yes and Activate temperature limitation parameter is selected as yes

13.2.143 Temperature controller – Limit temperature hysteresis

| | |
|---------|-----------|
| Options | 0.5 to 5K |
|---------|-----------|

The hysteresis on the limit temperature specifies the value by which the limit temperature must be dropped below again (heating) or exceeded (cooling) before the controller becomes active again.



Note: This parameter is only visible if Extended settings parameter is selected as yes and Activate temperature limitation parameter is selected as yes.

13.2.144 Temperature controller – Input for temperature limit sensor

| | |
|---------|--|
| Options | Via group object Via physical device input a Via physical device input b |
|---------|--|

A temperature sensor must be actually connected to the temperature input selected and the input for the sensor must have been correctly parameterized, otherwise the limit temperature function does not work. If one of the device inputs is selected here as the input for the limit temperature, this input is no longer used to acquire the room temperature. It is therefore not possible to use the same temperature sensor for the measurement of the room temperature and for the measurement of the limit temperature.

- Via group object: The temperature value is received via a dedicated group object. The dependent Basic-stage cooling limit temperature group object is enabled.
- Via physical device input x: The temperature value is acquired via a temperature sensor connected (to the selected input).



Note: This parameter is only visible if Extended settings parameter is selected as yes and Activate temperature limitation parameter is selected as yes.

13.2.145 Temperature controller – PI continuous (0...100 %), PI PWM (On/Off), PI continuous (0...100 %) for Fan Coil

The following parameters are enabled if the PI continuous (0...100 %), PI PWM (On/Off) or PI continuous (0...100 %) for Fan Coil option has been selected in the Basic-stage cooling control value type parameter.

13.2.146 Temperature controller – P-proportion

| | |
|---------|-----------|
| Options | 1 to 10 K |
|---------|-----------|

The P-proportion stands for the proportional range in a control. It fluctuates around the setpoint and in a PI control is used to change the speed of the control. The smaller the value set, the faster the control reacts. However, the value should not be set too small because otherwise there may be a risk of overshoot.

The standard value depends on the option selected in the Basic-stage cooling parameter in the Application parameters parameter window.



Note: This parameter is only visible if the Free configuration option has been selected for the Basic-stage cooling parameter in the Application parameters parameter window

13.2.147 Temperature controller – I-proportion

| | |
|---------|--------------|
| Options | 0 to 255 min |
|---------|--------------|

The I-proportion stands for the integral time in a control. The integral proportion causes the room temperature to approach the setpoint slowly and also to reach it finally. Depending on the system type used, the integral time may need to have different values. In principle the following applies: The more sluggish the overall system, the larger the integral time is

The standard value depends on the option selected in the Basic-stage cooling parameter in the Application parameters parameter window.



Note: This parameter is only visible if the Free configuration option has been selected for the Basic-stage cooling parameter in the Application parameters parameter window.

13.2.148 Temperature controller – Use control value for fan automation

| | |
|---------|-----------|
| Options | No Yes |
|---------|-----------|

This parameter can be used to specify whether the control value for this stage is also to be used as the control value for the fan automation. If the related stage has a free configuration, the device does not know whether the stage actuated is a fan coil unit or not. However, because the fan automation only makes sense for the fan coil unit stages, an assignment must be made here.

If a free configuration is selected for all 4 control stages and none of the stages is also parameterized for fan automation, the fan automation remains without function.

- No: The control value is not used for the fan automation.
- Yes: The control value is used for the fan automation. If this stage is active and the fan is in the automatic mode, the control value is also used as a control value to actuate the fan.



Note: This parameter is only visible if the Free configuration option has been selected for the Basic-stage cooling parameter in the Application parameters parameter window.

13.2.149 Temperature controller – Extended settings

| | |
|---------|-----------|
| Options | No Yes |
|---------|-----------|

Extended settings can be enabled using this parameter. This parameter is displayed on the selection of the Yes option.

13.2.150 Temperature controller – Control value direction

| | |
|---------|--------|
| Options | Normal |
|---------|--------|

| | |
|--|----------|
| | Inverted |
|--|----------|

This parameter is used to specify the control value direction if it is only output via a group object. The setting is used to actuate NC (normally closed) or NO (normally opened) valves. If one of the physical device outputs is used to output the control value, this parameter is not displayed because this setting is then made in the related output stage.

- Normal: The control value is output normally. Control value On/100 % => telegram value On/100 %, Control value Off/0 % => telegram value Off/0 %
- Inverted: The control value is output inverted. Control value On/100% => telegram Off/0 %, Control value Off/0 % => telegram On/100%



Note: This parameter is only visible if the Via group object option has been selected for the Actuate basic-stage cooling via parameter in the Application parameters parameter window and Extended settings parameter is selected as Yes.

13.2.151 Temperature controller – Control value difference for sending control value

| | |
|---------|--|
| Options | 2 % 5 % 10 % Only send cyclically |
|---------|--|

The control values for the PI continuous controller 0...100 % are not sent after each calculation, but when there is a difference in the calculation compared to the last value sent and sending is appropriate. This value difference can be entered here.



Note: This parameter is only visible on the selection of the PI continuous (0...100 %) or PI continuous (0...100 %) for Fan Coil option.

13.2.152 Temperature controller – Send control value cyclically (0 = cyclical sending disabled)

| | |
|---------|-------------|
| Options | 0 to 60 min |
|---------|-------------|

This parameter is used to specify the cycle time with which the control value is to be sent. On the selection of the value 0, cyclic sending is deactivated. If the control value is only output via a group object, this value should not be set to 0 because otherwise it will not be ensured that the actuator receives its control value. In particular, in combination with the Control value difference for sending control value parameter and the Only send cyclically option that can be selected there, the value 0 is not allowed to be selected. This configuration would mean that the control value is never output.



Note: This parameter is only visible on the selection of the 2-point 1 bit (On/Off), 2-point 1 byte (0/100%), PI continuous (0...100 %) or PI continuous (0...100 %) for Fan Coil option and Extended settings parameter is selected as Yes.

13.2.153 Temperature controller – Cooling PWM cycle

| | |
|---------|-------------|
| Options | 1 to 60 min |
|---------|-------------|

Using the value set here, the cycle time for the control value for the PWM signal calculated from the PI controller's control value is specified. Depending on the control value, the selected cycle time is divided into an On and Off signal. Therefore, a control value output of 33 % with a PWM cycle of 15 min signifies an On phase of five minutes and an Off phase of 10 min.

The value is only sent if the control value changes (from 0 to 1 or vice versa). At the start of a cycle a 1 is output and, corresponding to the control value, a 0 after the time x. If the control value is 0 %, on reaching this control value a 0 is output once. The next value is only sent if the control value changes.

Example:

Cooling PWM cycle: 15 min

Control value: 33 %

| Times | Sent value |
|--------|------------|
| 0 min | 1 |
| 5 min | 0 |
| 15 min | 1 |
| 20 min | 0 |
| 30 min | 1 |

... ..

New control value: 0 %

| Times | Sent value |
|--------|------------|
| 60 min | 0 |
| 75 min | – |
| 90 min | – |

... ..

New control value: 66 %

| Times | Sent value |
|---------|------------|
| 120 min | 1 |
| 130 min | 0 |
| 135 min | 1 |
| 145 min | 0 |

... ..



Note: This parameter is only visible on the selection of the PI PWM (On/Off) option and Extended settings parameter is selected as Yes.

13.2.154 Temperature controller – Max. control value

| | |
|---------|-----------|
| Options | 1 to 100% |
|---------|-----------|

The maximum control value from the PI controller specifies the maximum value that the controller outputs. If a maximum value below 255 is selected, then this value is not exceeded even if the controller calculates a higher control value.



Note: This parameter is only visible on the selection of Extended settings parameter is selected as Yes.

13.2.155 Temperature controller – Min. control value (basic load)

| | |
|---------|-----------|
| Options | 0 to 100% |
|---------|-----------|

The minimum control value from the PI controller specifies the minimum value that the controller outputs. If a minimum value greater than zero is selected, then this value is not dropped below even if the controller calculates a lower control value. This parameter is used to set a basic load, e.g. for the operation of ceiling cooling. Even if the controller calculates the control value zero, cooling medium flows through the ceiling cooling to prevent the room from heating up. In the Temperature controller parameter window, it can be set whether this basic load is to be active permanently or is to be switched via the Basic load group object. In addition, it can be set here whether the basic load is also to be active if the controller is switched off.



Note: This parameter is only visible on the selection of Extended settings parameter is selected as Yes.

13.2.156 Temperature controller – Activate temperature limitation

| | |
|---------|-----------|
| Options | No Yes |
|---------|-----------|

A controller limit temperature can be activated using this parameter. Using the limit temperature, the controller's control value for this stage can be set to 0 on reaching a parameterized temperature. In this way, exceeding (heating) or dropping below (cooling) this temperature can be prevented. An example of the usage of the limit temperature is floor heating, where exceeding a specific temperature must be prevented to protect the material of the floor.

- No: The limit temperature is deactivated.
- Yes: The limit temperature is activated. The following dependent parameters are also displayed.



Note: This parameter is only visible if Extended settings parameter is selected as Yes.

13.2.157 Temperature controller – Limited temperature

| | |
|---------|----------------|
| Options | 1 to 30 degree |
|---------|----------------|

The value set here specifies the limit temperature that is not allowed to be exceeded (heating) or dropped below (cooling). If the temperature reaches this value, the control value is immediately set to 0. The value set here is compared with the value received via a group object or via one of the physical device inputs (depending on the option selected, in the Input for temperature limit sensor parameter).



Note: This parameter is only visible if Extended settings parameter is selected as yes and Activate temperature limitation parameter is selected as yes.

13.2.158 Temperature controller – Limit temperature hysteresis

| | |
|---------|-----------|
| Options | 0.5 to 5K |
|---------|-----------|

The hysteresis on the limit temperature specifies the value by which the limit temperature must be dropped below again (heating) or exceeded (cooling) before the controller becomes active again.



Note: This parameter is only visible if Extended settings parameter is selected as yes and Activate temperature limitation parameter is selected as yes.

13.2.159 Temperature controller – I-proportion on temperature limitation

| | |
|---------|-----------------|
| Options | Freeze Reset |
|---------|-----------------|

This parameter decides what is to happen to the I-proportion on reaching the limit temperature.

- Freeze: The I-proportion is frozen at the actual value. As soon as the controller is active again, it continues to operate with the same I-proportion as before reaching the limit.
- Reset: The I-proportion is reset to 0. Once the controller becomes active again, the I-proportion starts at 0.



Note: This parameter is only visible if Extended settings parameter is selected as Yes.

13.2.160 Temperature controller – Input for temperature limit sensor

| | |
|---------|--|
| Options | Via group object Via physical device input a Via physical device input b |
|---------|--|

A temperature sensor must be actually connected to the temperature input selected and the input for the sensor must have been correctly parameterized, otherwise the limit temperature function does not work. If one of the device inputs is selected here as the input for the limit temperature, this input is no longer used to acquire the room temperature. It is therefore not possible to use the same temperature sensor for the measurement of the room temperature and for the measurement of the limit temperature.

- Via group object: The temperature value is received via a dedicated group object. The dependent Basic-stage cooling limit temperature group object is enabled.
- Via physical device input x: The temperature value is acquired via a temperature sensor connected (to the selected input).



Note: This parameter is only visible if Extended settings parameter is selected as yes and Activate temperature limitation parameter is selected as yes.

13.2.161 Temperature controller – Additional-stage cooling

This window is only visible if the Deactivated option has not been selected in the Additional-stage cooling parameter in the Application parameters parameter window. The additional-stage cooling of the temperature controller is parameterized in this window. The settings for the control type, limitation of the control range, the behavior on sending the control value and the limit temperature are made.

13.2.162 Temperature controller – Additional-stage cooling control value type

| | |
|---------|--|
| Options | 2-point 1 bit (On/Off) 2-point 1 byte (0/100 %) PI continuous (0...100 %) PI PWM (On/Off) PI continuous (0...100 %) for Fan Coil |
|---------|--|

This parameter is used to specify the control and control value type for the Additional-stage cooling. The standard value for the parameter is dependent on the selection in the Additional-stage cooling and Actuate Additional-stage cooling via parameters (Application parameters parameter window). On the selection of one of the physical device outputs for the actuation of the Additional-stage cooling, the controller has a fixed pre-configuration that cannot be changed. The pre-configured controller type is dependent here on the option selected in the Additional-stage cooling parameter. The only exception is on the selection of Free configuration. In this situation, everything can be selected and set freely.

The following table shows the dependencies:

| Option selected: Basic-stage Cooling | Preconfigured controller type: type of cooling control value | Controller type can be changed |
|--------------------------------------|--|--------------------------------|
| Area cooling (e.g. cooling ceiling) | PI continuous (0...100 %) | No |
| Free configuration | PI continuous (0...100 %) | Yes |
| Fan coil unit: Water cooling coil | PI continuous (0...100 %) for Fan Coil | No |

The differences between the individual controller types are explained in the following:

- 2-point 1 bit (On/Off): 2-point control is the simplest form of control. The controller switches on if the room temperature has dropped below a specific level (temperature setpoint minus hysteresis) and off as soon as a specific value (temperature setpoint plus hysteresis) is exceeded. The switch-on and switch-off commands are sent as 1-bit commands. The dependent Status Control value Basic-stage heating group object is enabled as a 1-bit group object.
- 2-point 1 byte (0/100 %): This is also two-point control as above. The difference is that switch on and switch-off commands are sent as 1-byte values (0 %/100 %). The dependent Status Control value Basic-stage heating group object is enabled as a 1-byte group object.
- PI continuous (0...100 %): The PI controller adjusts its output value, between 0 % and 100 %, to the difference between the actual value and setpoint and permits exact regulation of the room temperature to the setpoint. It outputs the control value on the bus as a 1-byte value (0...100 %). To reduce the bus load, the control value is only sent if it has changed by a previously specified percentage in relation to the value sent last. In addition, the control value can be sent cyclically. The dependent Status Control value Basic-stage heating group object is enabled as a 1-byte group object.

- PI PWM (On/Off): This is also a PI controller. The output is as a 1-bit command. For this purpose, the control value calculated is implemented using a pulse-pause ratio. The dependent Status Control value Basic-stage heating group object is enabled as a 1-bit group object.
- PI continuous (0...100 %) for Fan Coil: The fan coil controller operates like the PI continuous controller. In addition, the fan output is also actuated in the automatic mode corresponding to the control value for the basic-stage heating. The dependent Status Control value Basic-stage heating group object is enabled as a 1-byte group object.

13.2.163 Temperature controller – 2-point 1 bit (On/Off), 2-point 1 byte (0/100%)

The following parameters are enabled if the 2-point 1 bit (On/Off) or 2-point 1 byte (0/100%) option has been selected in the Additional-stage cooling control value type parameter

13.2.164 Temperature difference from basic-stage cooling

| | |
|---------|------------|
| Options | 0 to 25.5K |
|---------|------------|

The temperature difference from basic-stage cooling specifies the value from which or up to which the additional-stage cooling is to be active. If the actual temperature is below the setpoint temperature by the value selected here, the additional stage is active.

This action occurs both if the actual temperature drops below the threshold and if it is already below the threshold.

Example 1:

Temperature difference from basic-stage cooling: 2 K

Setpoint temperature: 23 °C

Actual temperature: 27 °C

Additional stage is active until the actual temperature reaches 25 °C.

Example 2:

Temperature difference from basic-stage cooling: 2 K

Setpoint temperature: 23 °C

Actual temperature: 24 °C

Additional stage is inactive as long as the actual temperature is above 25 °C.

13.2.165 Temperature controller – Use control value for fan automation

| | |
|---------|-----------|
| Options | No Yes |
|---------|-----------|

This parameter can be used to specify whether the control value for this stage is also to be used as the control value for the fan automation. If the related stage has a free configuration, the device does not know whether the stage actuated is a fan coil unit or not. However, because the fan automation only makes sense for the fan coil unit stages, an assignment must be made here.

If a free configuration is selected for all 4 control stages and none of the stages is also parameterized for fan automation, the fan automation remains without function.

- No: The control value is not used for the fan automation.
- Yes: The control value is used for the fan automation. If this stage is active and the fan is in the automatic mode, the control value is also used as a control value to actuate the fan.



Note: This parameter is only visible if the Free configuration option has been selected for the additional-stage cooling parameter in the Application parameters parameter window.

13.2.166 Temperature controller – Extended settings

| | |
|---------|-----------|
| Options | No Yes |
|---------|-----------|

Extended settings can be enabled using this parameter. This parameter is displayed on the selection of the Yes option.

13.2.167 Temperature controller – Control value direction

| | |
|---------|--------------------|
| Options | Normal Inverted |
|---------|--------------------|

This parameter is used to specify the control value direction if it is only output via a group object. The setting is used to actuate NC (normally closed) or NO (normally opened) valves. If one of the physical device outputs is used to output the control value, this parameter is not displayed because this setting is then made in the related output stage.

- Normal: The control value is output normally. Control value On/100 % => telegram value On/100 %, Control value Off/0 % => telegram value Off/0 %
- Inverted: The control value is output inverted. Control value On/100% => telegram Off/0 %, Control value Off/0 % => telegram On/100%



Note: This parameter is only visible if the Via group object option has been selected for the Actuate additional-stage cooling via parameter in the Application parameters parameter window and Extended settings parameter is selected as Yes.

13.2.168 Temperature controller – Hysteresis

This parameter is used to specify the hysteresis that is to apply to the setpoint to prevent continuous switching of the controller.

| | |
|---------|---------------|
| Options | 0.3 to 25.5 K |
|---------|---------------|

- Upper switching point = setpoint + hysteresis
- Lower switching point = setpoint – hysteresis

Heating controller:

- If the actual temperature is below the lower switching point, the controller switches on.
- If the actual temperature is above the upper switching point, the controller switches off.

Cooling controller:

- If the actual temperature is below the lower switching point, the controller switches off.
- If the actual temperature is above the upper switching point, the controller switches on.



Note: This parameter is only visible if Extended settings parameter is selected as Yes

13.2.169 Temperature controller – Send control value cyclically (0 = cyclical sending disabled)

| | |
|---------|-------------|
| Options | 0 to 60 min |
|---------|-------------|

This parameter is used to specify the cycle time with which the control value is to be sent. On the selection of the value 0, cyclic sending is deactivated. If the control value is only output via a group object, this value should not be set to 0 because otherwise it will not be ensured that the actuator receives its control value. In particular, in combination with the Control value difference for sending control value parameter and the Only send cyclically option that can be selected there, the value 0 is not allowed to be selected. This configuration would mean that the control value is never output.



Note: This parameter is only visible on the selection of the 2-point 1 bit (On/Off), 2-point 1 byte (0/100%), PI continuous (0...100 %) or PI continuous (0...100 %) for Fan Coil option and Extended settings parameter is selected as Yes.

13.2.170 Temperature controller – Activate temperature limitation

| | |
|---------|-----------|
| Options | No Yes |
|---------|-----------|

A controller limit temperature can be activated using this parameter. Using the limit temperature, the controller's control value for this stage can be set to 0 on reaching a parameterized temperature. In this way, exceeding (heating) or dropping below (cooling) this temperature can be prevented. An example of the usage of the limit temperature is a cooling ceiling, where dropping below a specific temperature must be prevented to protect the material of the ceiling against excessive cooling.

- No: The limit temperature is deactivated.
- Yes: The limit temperature is activated. The following dependent parameters are also displayed.



Note: This parameter is only visible if Extended settings parameter is selected as Yes

13.2.171 Temperature controller – Limited temperature

| | |
|---------|----------------|
| Options | 1 to 30 degree |
|---------|----------------|

The value set here specifies the limit temperature that is not allowed to be exceeded (heating) or dropped below (cooling). If the temperature reaches this value, the control value is immediately set to 0. The value set here is compared with the value received via a group object or via one of the physical device inputs (depending on the option selected, in the Input for temperature limit sensor parameter).



Note: This parameter is only visible if Extended settings parameter is selected as yes and Activate temperature limitation parameter is selected as yes

13.2.172 Temperature controller – Limit temperature hysteresis

| | |
|---------|-----------|
| Options | 0.5 to 5K |
|---------|-----------|

The hysteresis on the limit temperature specifies the value by which the limit temperature must be dropped below again (heating) or exceeded (cooling) before the controller becomes active again.



Note: This parameter is only visible if Extended settings parameter is selected as yes and Activate temperature limitation parameter is selected as yes.

13.2.173 Temperature controller – Input for temperature limit sensor

| | |
|---------|--|
| Options | Via group object Via physical device input a Via physical device input b |
|---------|--|

A temperature sensor must be actually connected to the temperature input selected and the input for the sensor must have been correctly parameterized, otherwise the limit temperature function does not work. If one of the device inputs is selected here as the input for the limit temperature, this input is no longer used to acquire the room temperature. It is therefore not possible to use the same temperature sensor for the measurement of the room temperature and for the measurement of the limit temperature.

- Via group object: The temperature value is received via a dedicated group object. The dependent additional-stage cooling limit temperature group object is enabled.
- Via physical device input x: The temperature value is acquired via a temperature sensor connected (to the selected input).



Note: This parameter is only visible if Extended settings parameter is selected as yes and Activate temperature limitation parameter is selected as yes.

13.2.174 Temperature controller – PI continuous (0...100 %), PI PWM (On/Off), PI continuous (0...100 %) for Fan Coil

The following parameters are enabled if the PI continuous (0...100 %), PI PWM (On/Off) or PI continuous (0...100 %) for Fan Coil option has been selected in the additional-stage cooling control value type parameter.

13.2.175 Temperature controller – P-proportion

| | |
|---------|-----------|
| Options | 1 to 10 K |
|---------|-----------|

The P-proportion stands for the proportional range in a control. It fluctuates around the setpoint and in a PI control is used to change the speed of the control. The smaller the value set, the faster the control reacts. However, the value should not be set too small because otherwise there may be a risk of overshoot.

The standard value depends on the option selected in the additional-stage cooling parameter in the Application parameters parameter window.



Note: This parameter is only visible if the Free configuration option has been selected for the additional-stage cooling parameter in the Application parameters parameter window

13.2.176 Temperature controller – I-proportion

| | |
|---------|--------------|
| Options | 0 to 255 min |
|---------|--------------|

The I-proportion stands for the integral time in a control. The integral proportion causes the room temperature to approach the setpoint slowly and also to reach it finally. Depending on the system type used, the integral time may need to have different values. In principle the following applies: The more sluggish the overall system, the larger the integral time is

The standard value depends on the option selected in the additional-stage cooling parameter in the Application parameters parameter window.



Note: This parameter is only visible if the Free configuration option has been selected for the additional-stage cooling parameter in the Application parameters parameter window.

13.2.177 Temperature controller – Use control value for fan automation

| | |
|---------|-----------|
| Options | No Yes |
|---------|-----------|

This parameter can be used to specify whether the control value for this stage is also to be used as the control value for the fan automation. If the related stage has a free configuration, the device does not know whether the stage actuated is a fan coil unit or not. However, because the fan automation only makes sense for the fan coil unit stages, an assignment must be made here.

If a free configuration is selected for all 4 control stages and none of the stages is also parameterized for fan automation, the fan automation remains without function.

- No: The control value is not used for the fan automation.
- Yes: The control value is used for the fan automation. If this stage is active and the fan is in the automatic mode, the control value is also used as a control value to actuate the fan.



Note: This parameter is only visible if the Free configuration option has been selected for the additional-stage cooling parameter in the Application parameters parameter window.

13.2.178 Temperature controller – Extended settings

| | |
|---------|-----------|
| Options | No Yes |
|---------|-----------|

Extended settings can be enabled using this parameter. This parameter is displayed on the selection of the Yes option.

13.2.179 Temperature controller – Control value direction

| | |
|---------|--------------------|
| Options | Normal Inverted |
|---------|--------------------|

This parameter is used to specify the control value direction if it is only output via a group object. The setting is used to actuate NC (normally closed) or NO (normally opened) valves. If one of the physical device outputs is used to output the control value, this parameter is not displayed because this setting is then made in the related output stage.

- Normal: The control value is output normally. Control value On/100 % => telegram value On/100 %, Control value Off/0 % => telegram value Off/0 %
- Inverted: The control value is output inverted. Control value On/100% => telegram Off/0 %, Control value Off/0 % => telegram On/100%



Note: This parameter is only visible if the Via group object option has been selected for the Actuate additional-stage cooling via parameter in the Application parameters parameter window and Extended settings parameter is selected as Yes.

13.2.180 Temperature controller – Control value difference for sending control value

| | |
|---------|--|
| Options | 2 % 5 % 10 % Only send cyclically |
|---------|--|

The control values for the PI continuous controller 0...100 % are not sent after each calculation, but when there is a difference in the calculation compared to the last value sent and sending is appropriate. This value difference can be entered here.



Note: This parameter is only visible on the selection of the PI continuous (0...100 %) or PI continuous (0...100 %) for Fan Coil option.

13.2.181 Temperature controller – Send control value cyclically (0 = cyclical sending disabled)

| | |
|---------|-------------|
| Options | 0 to 60 min |
|---------|-------------|

This parameter is used to specify the cycle time with which the control value is to be sent. On the selection of the value 0, cyclic sending is deactivated. If the control value is only output via a group object, this value should not be set to 0 because otherwise it will not be ensured that the actuator receives its control value. In particular, in combination with the Control value difference for sending control value parameter and the Only send cyclically option that can be selected there, the value 0 is not allowed to be selected. This configuration would mean that the control value is never output.



Note: This parameter is only visible on the selection of the 2-point 1 bit (On/Off), 2-point 1 byte (0/100%), PI continuous (0...100 %) or PI continuous (0...100 %) for Fan Coil option and Extended settings parameter is selected as Yes.

13.2.182 Temperature controller – Cooling PWM cycle

| | |
|---------|-------------|
| Options | 1 to 60 min |
|---------|-------------|

Using the value set here, the cycle time for the control value for the PWM signal calculated from the PI controller's control value is specified. Depending on the control value, the selected cycle time is divided into an On and Off signal. Therefore, a control value output of 33 % with a PWM cycle of 15 min signifies an On phase of five minutes and an Off phase of 10 min.

The value is only sent if the control value changes (from 0 to 1 or vice versa). At the start of a cycle a 1 is output and, corresponding to the control value, a 0 after the time x. If the control value is 0 %, on reaching this control value a 0 is output once. The next value is only sent if the control value changes.

Example:

Cooling PWM cycle: 15 min

Control value: 33 %

| Times | Sent value |
|--------|------------|
| 0 min | 1 |
| 5 min | 0 |
| 15 min | 1 |
| 20 min | 0 |
| 30 min | 1 |

... ..

New control value: 0 %

| Times | Sent value |
|--------|------------|
| 60 min | 0 |
| 75 min | – |
| 90 min | – |

... ..

New control value: 66 %

| Times | Sent value |
|---------|------------|
| 120 min | 1 |
| 130 min | 0 |
| 135 min | 1 |
| 145 min | 0 |

... ..



Note: This parameter is only visible on the selection of the PI PWM (On/Off) option and Extended settings parameter is selected as Yes.

13.2.183 Temperature controller – Max. control value

| | |
|---------|-----------|
| Options | 1 to 100% |
|---------|-----------|

The maximum control value from the PI controller specifies the maximum value that the controller outputs. If a maximum value below 255 is selected, then this value is not exceeded even if the controller calculates a higher control value.



Note: This parameter is only visible on the selection of Extended settings parameter is selected as Yes.

13.2.184 Temperature controller – Min. control value (basic load)

| | |
|---------|-----------|
| Options | 0 to 100% |
|---------|-----------|

The minimum control value from the PI controller specifies the minimum value that the controller outputs. If a minimum value greater than zero is selected, then this value is not dropped below even if the controller calculates a lower control value. This parameter is used to set a basic load, e.g. for the operation of ceiling cooling. Even if the controller calculates the control value zero, cooling medium flows through the ceiling cooling to prevent the room from heating up. In the Temperature controller parameter window, it can be set whether this basic load is to be active permanently or is to be switched via the Basic load group object. In addition, it can be set here whether the basic load is also to be active if the controller is switched off.



Note: This parameter is only visible on the selection of Extended settings parameter is selected as Yes.

13.2.185 Temperature controller – Activate temperature limitation

| | |
|---------|-----------|
| Options | No Yes |
|---------|-----------|

A controller limit temperature can be activated using this parameter. Using the limit temperature, the controller's control value for this stage can be set to 0 on reaching a parameterized temperature. In this way, exceeding (heating) or dropping below (cooling) this temperature can be prevented. An example of the usage of the limit temperature is floor heating, where exceeding a specific temperature must be prevented to protect the material of the floor.

- No: The limit temperature is deactivated.
- Yes: The limit temperature is activated. The following dependent parameters are also displayed.



Note: This parameter is only visible if Extended settings parameter is selected as Yes.

13.2.186 Temperature controller – Limited temperature

| | |
|---------|----------------|
| Options | 1 to 30 degree |
|---------|----------------|

The value set here specifies the limit temperature that is not allowed to be exceeded (heating) or dropped below (cooling). If the temperature reaches this value, the control value is immediately set to 0. The value set here is compared with the value received via a group object or via one of the physical device inputs (depending on the option selected, in the Input for temperature limit sensor parameter).



Note: This parameter is only visible if Extended settings parameter is selected as yes and Activate temperature limitation parameter is selected as yes.

13.2.187 Temperature controller – Limit temperature hysteresis

| | |
|---------|-----------|
| Options | 0.5 to 5K |
|---------|-----------|

The hysteresis on the limit temperature specifies the value by which the limit temperature must be dropped below again (heating) or exceeded (cooling) before the controller becomes active again.



Note: This parameter is only visible if Extended settings parameter is selected as yes and Activate temperature limitation parameter is selected as yes.

13.2.188 Temperature controller – I-proportion on temperature limitation

| | |
|---------|-----------------|
| Options | Freeze Reset |
|---------|-----------------|

This parameter decides what is to happen to the I-proportion on reaching the limit temperature.

- Freeze: The I-proportion is frozen at the actual value. As soon as the controller is active again, it continues to operate with the same I-proportion as before reaching the limit.
- Reset: The I-proportion is reset to 0. Once the controller becomes active again, the I-proportion starts at 0.



Note: This parameter is only visible if Extended settings parameter is selected as Yes.

13.2.189 Temperature controller – Input for temperature limit sensor

| | |
|---------|--|
| Options | Via group object Via physical device input a Via physical device input b |
|---------|--|

A temperature sensor must be actually connected to the temperature input selected and the input for the sensor must have been correctly parameterized, otherwise the limit temperature function does not work. If one of the device inputs is selected here as the input for the limit temperature, this input is no longer used to acquire the room temperature. It is therefore not possible to use the same temperature sensor for the measurement of the room temperature and for the measurement of the limit temperature.

- Via group object: The temperature value is received via a dedicated group object. The dependent additional-stage cooling limit temperature group object is enabled.
- Via physical device input x: The temperature value is acquired via a temperature sensor connected (to the selected input).



Note: This parameter is only visible if Extended settings parameter is selected as yes and Activate temperature limitation parameter is selected as yes.

13.2.190 Setpoint manager

13.2.191 Setpoint manager - Operating modes

| | |
|---------|---|
| Options | Comfort, Standby, Economy, Building Protection Comfort, Standby, Building Protection Comfort, Building Protection |
|---------|---|

This parameter is used to select which operating modes are to be used. Depending on the selection, the operating modes not listed are removed. One possible application for the restriction of the operating modes used is buildings in which, e.g. Economy is not used because the change is always between Comfort and Standby. If the device is requested via a group object to change to one of the operating modes not available, the device remains in or changes instead to Comfort.

Explanation of the operating modes:

- Comfort: The room is used actively by a person/persons. The setpoint temperature is set correspondingly. In the Comfort mode the controller actively attempts to reach the room temperature specified (by heating or cooling).

- Standby: On a change to Standby, the temperature is allowed to drop (heating) or increase (cooling) to a specified value.

Only once this temperature is reached is the heating or cooling activated again.

Typically, the setpoints are 2-3 °C below/above the Comfort setpoint temperature.

The Standby mode is also used to increase/reduce the room temperature after a nighttime reduction (Economy) and expected imminent change to the Comfort mode such that it does not take too long to reach the Comfort temperatures. The change between Comfort and Standby can be made using the Operating mode group object, or, with presence detection in the room, via the Presence detector (master) group object. The reception of the presence value always results in a change to Comfort.

- Economy: This is also called nighttime reduction. Here the temperatures are allowed to drop (heating) or increase (cooling) to a different, lower/higher setpoint. The purpose is to obtain further energy savings during extended periods without use (e.g. overnight or during the weekend) because less energy must be used to maintain this temperature. The setpoints for Economy are typically 2-3 °C below/above the values for the Standby setpoint temperature. The change between Comfort and Standby can be made using the Operating mode group object, or, with presence detection in the room, via the Presence detector (master) group object.

The reception of the presence value always results in a change to Comfort

13.2.192 Operating mode after 230V recovery, ETS download and reset

| | |
|---------|--|
| Options | Comfort Standby Economy Building Protection |
|---------|--|

The parameter defines which operating mode is to apply after 230V recovery, ETS download and reset. The operating mode remains active until a new operating mode is set, e.g. via the *Operating mode* group object.



Note: This operating mode should be defined during the planning phase. If the operating mode is defined incorrectly, there may be a loss of comfort or increased energy consumption.

13.2.193 Setpoint manager - Comfort heating setpoint = Comfort cooling setpoint

| | |
|---------|-----------|
| Options | No Yes |
|---------|-----------|

This parameter is enabled if the controller has been parameterized both for heating and for cooling. For this purpose, Deactivated must not be selected for the parameters Basic-stage heating and Basic-stage cooling in the Application parameters parameter window.

This parameter defines how the comfort values for heating and cooling depend on each other.

- No: Two separate comfort setpoints are used for heating and cooling. The related active setpoint is output via the Current setpoint object. The changeover between heating and cooling is undertaken using the method defined in the Application parameters parameter window in the Heating/Cooling changeover parameter. On the selection of the Automatically option, the changeover between heating and cooling is dependent on the absolute temperatures set for Comfort heating/cooling.
- Yes: The device has one and the same setpoint for heating and cooling in the Comfort mode. The changeover to heating takes place on dropping below the setpoint minus the hysteresis. The changeover to cooling takes place on exceeding the setpoint plus the hysteresis. The hysteresis is parameterizable. The Comfort heating setpoint and Comfort cooling setpoint parameters are replaced by the Setpoint for Comfort heating and cooling parameter. In addition, the Hysteresis for Toggle heating/cooling parameter is displayed.

13.2.194 Setpoint manager - Comfort heating setpoint = Comfort cooling setpoint set as NO

13.2.195 Setpoint manager - Comfort heating setpoint

| | |
|---------|-------------|
| Options | 10 to 40 °C |
|---------|-------------|

This value defines the setpoint for the heating comfort temperature. If the device is in the type of operation heating and is changed to the Comfort operating mode, the device regulates to this temperature.



Note: This parameter is only visible if the Deactivated option has not been selected for the Basic-stage heating parameter in the Application parameters parameter window, and the No option has been selected for the Comfort heating setpoint = Comfort cooling setpoint parameter.

13.2.196 Setpoint manager - Comfort cooling setpoint

| | |
|---------|-------------|
| Options | 10 to 40 °C |
|---------|-------------|

This value defines the setpoint for the comfort cooling temperature. If the device is the type of operation cooling and is changed to the Comfort operating mode, the device regulates to this temperature.



Note: This parameter is only visible if the Deactivated option has not been selected for the Basic-stage cooling parameter in the Application parameters parameter window, and the No option has been selected for the Comfort heating setpoint = Comfort cooling setpoint parameter.

13.2.197 Setpoint manager - Comfort heating setpoint = Comfort cooling setpoint set as Yes

13.2.198 Setpoint manager - Hysteresis for Toggle heating/cooling

| | |
|---------|-------------|
| Options | 0.5 to 10°C |
|---------|-------------|

The parameter defines the hysteresis for the changeover between heating and cooling. If the room temperature exceeds the setpoint temperature plus hysteresis, the changeover is to cooling. If the room temperature drops below the setpoint temperature minus hysteresis, the changeover is to heating. A change between heating and cooling is only possible in the Comfort mode.



Note: This parameter is only visible if the Yes option has been selected for the Comfort heating setpoint = Comfort cooling setpoint parameter and heating/cooling changeover is automatic.

13.2.199 Setpoint manager - Setpoint for Comfort heating and cooling

| | |
|---------|------------|
| Options | 10 to 40°C |
|---------|------------|

This value defines the setpoint for the comfort temperature for heating and cooling. If the operating mode is changed to Comfort, the device regulates to this temperature in both types of operation heating and cooling.



Note: This parameter is only visible if the Yes option has been selected for the Comfort heating setpoint = Comfort cooling setpoint parameter.

13.2.200 Setpoint manager - Setpoint specification and adjustment

| | |
|---------|----------------------|
| Options | Absolute Relative |
|---------|----------------------|

This parameter is used to set the manner in which the setpoints are configured, as well as whether this can be changed. The values entered must, according to the type of operation (heating or cooling), be higher (cooling) or lower (heating) than the Comfort setpoint: Comfort heating setpoint > Standby heating setpoint > Economy heating setpoint > Setpoint for frost protection (building protection, heating) Comfort cooling setpoint < Standby cooling setpoint < Economy cooling setpoint < Heat protection setpoint (building protection, cooling) Failure to observe the sequence for the values may result in incorrect room temperature regulation.

- Absolute: Absolute values are used to enter the values for Standby and Economy heating and Standby and Economy cooling. I.e. the setpoint that is to become active on the activation of the related operating mode is specified. It is possible to change the values parameterized here using a dedicated group object. As such each operating mode setpoint can be changed independent of all other values. There is no common change by the basic setpoint. The dependent objects Comfort heating setpoint, Standby heating setpoint, Economy heating setpoint, Building protection heating setpoint, Comfort cooling setpoint, Standby cooling setpoint, Economy cooling setpoint and Building Protection cooling setpoint are displayed. The dependent parameters Standby heating setpoint, Economy heating setpoint, Standby cooling setpoint and Economy cooling setpoint are displayed.
- Relative: The setpoints for Standby and Economy heating and Standby and

Economy cooling are entered as values relative to the related Comfort heating or Comfort cooling setpoint. It is only possible to change all values at the same time using the Base setpoint group object. The base setpoint is defined using the Base setpoint is parameter. Depending on the value received via the Base setpoint group object, all other values are changed to suit the reduction or increase parameterized. It is not possible to change the setpoint for heat protection or the setpoint for frost protection via KNX using this method. The dependent Base setpoint group object is displayed. The dependent parameters Standby heating reduction, Economy heating reduction, Increase for Standby cooling, Increase for Economy cooling and Base setpoint is are displayed.

13.2.201 Setpoint manager - Selection of Setpoint specification and adjustment is Absolute

13.2.202 Setpoint manager - Standby heating setpoint

| | |
|---------|------------|
| Options | 10 to 40°C |
|---------|------------|

This parameter is used to set the temperature that is to apply in the Standby operating mode in the type of operation heating. The temperature stated here must be lower than the temperature selected in the Comfort heating setpoint or Setpoint for Comfort heating and cooling parameter. A temperature that is at least 2 °C lower is recommended.

The controller does not change the type of operation to reach this temperature, instead it ensures this temperature is not dropped below on a reduction in the actual temperature.



Note: This parameter is only visible if the device has been parameterized for heating and the Deactivated option has not been selected for the Basic-stage heating parameter in the Application parameters parameter window, and the Setpoint specification and adjustment parameter has been parameterized with the Absolute option.

13.2.203 Setpoint manager - Economy heating setpoint

| | |
|---------|------------|
| Options | 10 to 40°C |
|---------|------------|

This parameter is used to set the temperature that is to apply in the Economy operating mode in the type of operation heating. The temperature stated here must be lower than the temperature selected in the Standby heating setpoint parameter. A temperature that is at least 2 °C is recommended. The controller does not change the type of operation to reach this temperature, instead it ensures this temperature is not exceeded on an increase in the actual temperature.



Note: This parameter is only visible if the device has been parameterized for heating and the Deactivated option has not been selected for the Basic-stage heating parameter in the Application parameters parameter window, and the Setpoint specification and adjustment parameter has been parameterized with the Absolute option.

13.2.204 Setpoint manager - Standby cooling setpoint

| | |
|---------|------------|
| Options | 10 to 40°C |
|---------|------------|

This parameter is used to set the temperature that is to apply in the Standby operating mode in the type of operation cooling. The temperature stated here must be higher than the temperature selected in the Comfort cooling setpoint or Setpoint for Comfort heating and cooling parameter. A temperature that is at least 2 °C higher is recommended. The controller does not change the type of operation to reach this temperature, instead it ensures this temperature is not exceeded on an increase in the actual temperature.



Note: This parameter is only visible if the device has been parameterized for cooling and the Deactivated option has not been selected for the Basic-stage cooling parameter in the Application parameters parameter window, and the Setpoint specification and adjustment parameter has been parameterized with the Absolute option.

13.2.205 Setpoint manager - Economy cooling setpoint

| | |
|---------|------------|
| Options | 10 to 40°C |
|---------|------------|

This parameter is used to set the temperature that is to apply in the Economy operating mode in the type of operation cooling. The temperature stated here must be higher than the temperature selected in the Standby cooling setpoint parameter. A temperature that is at least 2 °C higher is recommended. The controller does not change the type of operation to reach this temperature, instead it ensures this temperature is not exceeded on an increase in the actual temperature.



Note: This parameter is only visible if the device has been parameterized for cooling and the Deactivated option has not been selected for the Basic-stage cooling parameter in the Application parameters parameter window, and the Setpoint specification and adjustment parameter has been parameterized with the Absolute option.

13.2.206 Setpoint manager - Selection of Setpoint specification and adjustment is Relative

13.2.207 Setpoint manager - Standby heating reduction

| | |
|---------|----------|
| Options | 0 to 15K |
|---------|----------|

This parameter is used to set the temperature that is to apply in the Standby operating mode in the type of operation heating. This is defined here as the reduction in relation to the Comfort heating setpoint. The controller does not change the type of operation to reach this temperature, instead it ensures this temperature is not exceeded on an increase in the actual temperature.



Note: This parameter is only visible if the device has been parameterized for heating and the Deactivated option has not been selected for the Basic-stage heating parameter in the Application parameters parameter window, and the Setpoint specification and adjustment parameter has been parameterized with the Relative option

13.2.208 Setpoint manager - Economy heating reduction

| | |
|---------|----------|
| Options | 0 to 15K |
|---------|----------|

This parameter is used to set the temperature that is to apply in the Economy operating mode in the type of operation heating. This is defined here as the reduction in relation to the Comfort heating setpoint. The controller does not change the type of operation to reach this temperature, instead it ensures this temperature is not exceeded on an increase in the actual temperature.



Note: This parameter is only visible if the device has been parameterized for heating and the Deactivated option has not been selected for the Basic-stage heating parameter in the Application parameters parameter window, and the Setpoint specification and adjustment parameter has been parameterized with the Relative option.

13.2.209 Setpoint manager - Increase for Standby cooling

| | |
|---------|----------|
| Options | 0 to 15K |
|---------|----------|

This value is used to set the temperature that is to apply in the Standby operating mode in the type of operation cooling. This is defined here as the increase in relation to the comfort cooling setpoint. The controller does not change the type of operation to reach this temperature, instead it ensures this temperature is not exceeded on an increase in the actual temperature.



Note: This parameter is only visible if the device has been parameterized for cooling and the Deactivated option has not been selected for the Basic-stage cooling parameter in the Application parameters parameter window, and the No option has been selected for the Comfort heating setpoint = Comfort cooling setpoint parameter.

13.2.210 Setpoint manager – Increase for Economy cooling

| | |
|---------|----------|
| Options | 0 to 15K |
|---------|----------|

This parameter is used to set the temperature that is to apply in the Economy operating mode in the type of operation cooling. This is defined here as the increase in relation to the comfort cooling setpoint. The controller does not change the type of operation to reach this temperature, instead it ensures this temperature is not exceeded on an increase in the actual temperature.



Note: This parameter is only visible if the device has been parameterized for cooling and the Deactivated option has not been selected for the Basic-stage cooling parameter in the Application parameters parameter window, and the No option has been selected for the Comfort heating setpoint = Comfort cooling setpoint parameter.

13.2.211 Setpoint manager - Base setpoint is

| | |
|---------|--|
| Options | Comfort heating setpoint Comfort cooling setpoint Mean value between Comfort heating and cooling |
|---------|--|

If the device has been configured only for the type of operation heating or the type of operation cooling, the base setpoint is automatically the same as the Comfort setpoint for this stage and can also not be changed. This parameter is used to define

which value corresponds to the base setpoint. It is possible to change the setpoints parameterized for Comfort, Standby and Economy via the KNX bus using the base setpoint. Depending on the option selected, the new base setpoint changes the value selected directly. All other values are changed according to their relative distance from this value. The values parameterized are overwritten with this change. It is not possible to change the setpoints for frost protection and heat protection using the base setpoint. If the basic-stage heating or the basic-stage cooling has been deactivated, the base setpoint is fixed to the other comfort value for the existing type of operation.



Note: This parameter is only visible if the Setpoint specification and adjustment parameter has been parameterized with the Relative option

13.2.212 Setpoint manager - Setpoint for frost protection (building protection, heating)

| | |
|---------|-----------|
| Options | 5 to 15°C |
|---------|-----------|

This parameter is used to set the temperature that is to apply in the Building Protection operating mode in the type of operation heating. This setpoint temperature also becomes active if the controller receives the information "Window open", or is deactivated via the Request On/Off (Master) group object. The controller does not change the type of operation to reach this temperature, instead it ensures this temperature is not dropped below on a reduction in the actual temperature. This setpoint is used to protect the building and the installation against damage, and at the same time to prevent unnecessary energy wastage. For this reason, the temperature should not be selected too low, and also not too high.

An example of this aspect is the opening of a window: As long as the window is open, further heating will waste energy. However, if the outside temperature is very low (e.g. 0 °C), the room temperature will continuously approach this temperature. Here there is a risk of the installation freezing and also frost damage to the equipment in the room. To prevent this situation from arising, the controller becomes active again on reaching the temperature set and attempts to prevent dropping below this temperature. However, if the setpoint for frost protection is selected too high, the controller starts this attempt much earlier, e.g. at a time that is acceptable during normal airing and wastes unnecessary energy.

13.2.213 Setpoint manager - Heat protection setpoint (building protection, cooling)

| | |
|---------|------------|
| Options | 27 to 45°C |
|---------|------------|

This parameter is used to set the temperature that is to apply in the Building Protection operating mode in the type of operation cooling. This setpoint temperature also becomes active if the controller receives the information "Window open", "Fill level alarm" or "Dew point alarm", or is deactivated via the Request On/Off (Master) group object. The controller does not change the type of operation to reach this temperature, instead it ensures this temperature is not exceeded on an increase in the actual temperature. This setpoint is used to protect the building and the installation against damage, and at the same time to prevent unnecessary energy wastage. For this reason, the temperature should not be selected too high, and also not too low.

An example of this aspect is the opening of a window: As long as the window is open, further cooling will waste energy. However, if the outside temperature is very high (e.g. 50 °C), the room temperature will continuously approach this temperature. Here there is a risk of persons becoming too hot and also damage to the installation and the equipment in the room. To prevent this situation from arising, the controller becomes active again on reaching the temperature set and attempts to prevent exceeding this temperature. However, if the setpoint for heat protection is selected too high, the controller starts this attempt much earlier, e.g. at a time that is acceptable on opening a window, and wastes unnecessary energy

13.2.214 Setpoint manager - Send current setpoint

| | |
|---------|---------------------------------------|
| Options | On change and cyclically On change |
|---------|---------------------------------------|

This parameter is used to define when the setpoint currently valid is to be sent via the Current setpoint group object.

13.2.215 Setpoint manager - Send current setpoint cyclically

| | |
|---------|--------------|
| Options | 5 to 240 Min |
|---------|--------------|

The cycle time with which the current setpoint is to be sent is specified here.



Note: This parameter is only visible if the On change and cyclically option has been selected in the Send current setpoint parameter.

13.2.216 Setpoint manager - Summer compensation

| | |
|---------|-----------|
| Options | No Yes |
|---------|-----------|

The summer compensation in the device can be activated using this parameter. The summer compensation is used to obtain energy savings by increasing the setpoint depending on the outside temperature to prevent large temperature differences between room and outside temperature and the related risk of a heat shock.

- No: The summer compensation is deactivated
- Yes: The summer compensation is activated. The dependent group objects Outside temperature for summer compensation and Summer compensation active/inactive are displayed. The dependent parameters (Lower) starting temperature for summer compensation, Setpoint temperature offset when summer compensation starts, (Upper) escape temperature for summer compensation and Setpoint temperature offset when summer compensation ends are displayed.



Note: This parameter is only visible if the device has been parameterized for cooling and the Deactivated option has not been selected for the Basic-stage cooling parameter in the Application parameters parameter window.

13.2.217 Setpoint manager - (Lower) starting temperature for summer compensation

| | |
|---------|------------|
| Options | 10 to 50°C |
|---------|------------|



Note: This parameter is only visible if the Yes option has been selected for the Summer compensation parameter.

13.2.218 Setpoint manager - Setpoint temperature offset when summer compensation starts

| | |
|---------|-------------|
| Options | 0 to 12.7°C |
|---------|-------------|



Note: This parameter is only visible if the Yes option has been selected for the Summer compensation parameter.

13.2.219 Setpoint manager - (Upper) escape temperature for summer compensation

| | |
|---------|------------|
| Options | 10 to 50°C |
|---------|------------|



Note: This parameter is only visible if the Yes option has been selected for the Summer compensation parameter.

13.2.220 Setpoint manager - Setpoint temperature offset when summer compensation ends

| | |
|---------|-------------|
| Options | 0 to 12.7°C |
|---------|-------------|



Note: This parameter is only visible if the Yes option has been selected for the Summer compensation parameter.

13.2.221 Monitoring and Safety

13.2.222 Monitoring and Safety - Use forced operation

| | |
|---------|--|
| Options | No Forced operation 1 bit; 1 active Forced operation 1 bit; 0 active Forced operation 2 bit |
|---------|--|

The usage of forced operation can be activated using this parameter. In addition, the selection of the parameter defines which type of forced operation is used. The forced operation is used to place the outputs on the device in a pre-defined state by switching a 1- or 2-bit group object. Forced operation overrides the normal control of the device (controller, value specifications via group objects). For the device to function normally, forced operation must be actively disabled. The state of the forced operation is saved on 230V failure and retrieved again on 230V recovery. If forced operation was active on 230V failure, it is also active after 230V recovery. Forced operation is deactivated on an ETS reset. Forced operation overrides the outputs and places them in a defined state. However, this action has no effect on the control values sent by the controller via the bus or the master/slave communication; this communication continues to take place. So that an actuator actuated by the controller in this device behaves the same, forced operation must be correspondingly parameterized also on this device and it must be linked to the same group address.

- Forced operation 1 bit; 1 active: Forced operation is enabled. The dependent group object Forced operation 1 bit is activated. Forced operation is activated on receiving

a "1" via this group object. If a "0" is received, forced operation is deactivated. The dependent parameters Control value, Fan output, Relay output are enabled.

- Forced operation 1 bit; 0 active: Forced operation is enabled. The dependent group object Forced operation 1 bit is activated. Forced operation is activated on receiving a "0" via this group object. If a "1" is received, forced operation is deactivated. The dependent parameters Control value, Fan output, Relay output are enabled.
- Forced operation 2 bit: Forced operation is enabled. The dependent group object Forced operation 2 bit is activated. The dependent parameters Control value for forced operation ON, Fan output for forced operation ON, Relay output for forced operation ON, Control value for forced operation OFF, Fan output for forced operation OFF and Relay output for forced operation OFF are enabled.

With forced operation 2 bit there can be two forced operation states (forced operation On and forced operation Off). These states are activated using the 2-bit group object. The first bit defines whether the forced operation is active (bit 1 (high) = 1) or inactive (bit 1 (high) = 0), the second bit decides on the Off (bit 2 (low) = 0) or On (bit 2 (low) = 1) state.

| Value | Bit 1 | Bit 0 | Status |
|-------|-------|-------|------------|
| 0 | 0 | 0 | Inactive |
| 1 | 0 | 1 | Inactive |
| 2 | 1 | 0 | Forced OFF |
| 3 | 1 | 1 | Forced ON |

Forced operation overrides the outputs and places them in a defined state. However, this action has no effect on the control values sent by the controller via the bus or the master/slave communication; this communication continues to take place. So that an actuator actuated by the controller in this device behaves the same, forced operation must be correspondingly parameterized also on this device and it must be linked to the same group address.



Note: The state of the forced operation is saved on bus voltage failure and retrieved again on bus voltage recovery. If forced operation was active on bus voltage failure, it is also active after bus voltage recovery. Forced operation is deactivated on an ETS reset.

13.2.223 Monitoring and Safety - Forced operation dependent parameters

The following parameters are available with forced operation activated. On the usage of the Forced operation 2 bit option, these parameters are available twice, once for the ON state and once for the OFF state.

13.2.224 Monitoring and Safety - Control value (Forced operation 1 bit; 1 active & Forced operation 1 bit; 0 active) / Control value for forced operation ON (Forced operation 2 bit) / Control value for forced operation OFF (Forced operation 2 bit)

| | |
|--|-----------|
| Control value (Forced operation 1 bit; 1 active) | 0 to 100% |
| Control value (Forced operation 1 bit; 0 active) | 0 to 100% |

| | |
|---|-----------|
| Control value for forced operation ON (Forced operation 2 bit) | 0 to 100% |
| Control value for forced operation OFF (Forced operation 2 bit) | 0 to 100% |

This parameter is used to specify the control value that is to apply with forced operation active (for 2-bit in the related state, ON or OFF). The control value refers only to the valve for the currently active type of operation (heating or cooling).

Both the basic and additional stage are output via the valve outputs (e.g. basic-stage heating = valve A; additional-stage heating = valve B), the value set here is converted into a control value for both stages. Here the range 0...50 % specifies the control value for the basic stage and the range from 51...100 % the control value for the additional stage, if the control value for the basic stage is 100 % at the same time.

Example:

Control value on forced operation

| Basic-stage control | value Additional-stage | control value |
|---------------------|------------------------|---------------|
| 0 % | 0 % | 0 % |
| 1 % | 2 % | 0 % |
| 25 % | 50 % | 0 % |
| 50 % | 100 % | 0 % |
| 51 % | 100 % | 2 % |
| 75 % | 100 % | 50 % |
| 100 % | 100 % | 100 % |

13.2.225 Monitoring and Safety - Fan output (Forced operation 1 bit; 1 active & Forced operation 1 bit; 0 active) / Fan output for forced operation ON (Forced operation 2 bit) / Fan output for forced operation OFF (Forced operation 2 bit)

| | |
|--|---|
| <ul style="list-style-type: none"> Fan output (Forced operation 1 bit; 1 active & Forced operation 1 bit; 0 active) | Unchanged Applies control value 1 2 3 |
| <ul style="list-style-type: none"> Fan output for forced operation ON (Forced operation 2 bit) | Unchanged Applies control value 1 2 3 |
| Fan output for forced operation OFF (Forced operation 2 bit) | Unchanged Applies control value 1 2 3 |

- Unchanged: The same fan speed as before the activation of the forced operation applies.
- Applies control value: The speed is dependent on the valve control value. The

automatic mode is active.

- 1: The fan runs at speed 1.
- 2: The fan runs at speed 2.
- 3: The fan runs at speed 3.

13.2.226 Monitoring and Safety - Cyclical monitoring

| | |
|---------|--------------------------|
| Options | Deactivated Activated |
|---------|--------------------------|

The cyclical monitoring is used to monitor specific, selected group objects for the correct function of the device. For each group object monitored it is possible to define a monitoring time during which the group object monitored must be received. If the group object is received in the defined time, the monitoring time starts again immediately after the reception of the group object. If the group object is not received in this time, it can be specified how the device is to behave. For all cyclically monitored group objects it is important to set the behavior of the sending device correctly. The group objects must be sent cyclically, and the cycle time must be less (= more frequent) than the receive time monitored. Recommendation: Monitoring time = 2 × sending cycle time Do not select times that are too low because this configuration can cause a high bus load and the probability of an error increases.

- Deactivated: The cyclical monitoring is deactivated.
- Activated: The cyclical monitoring is activated. The dependent parameters for monitoring the individual group objects are displayed. For each group object it is possible to decide separately whether it is to be monitored or not

13.2.227 Monitoring and Safety - Temperature input monitoring

| | |
|---------|--|
| Options | Deactivated On physical device input a On physical device input b On group object |
|---------|--|

The reception of a temperature value can be monitored using this parameter. Unlike the other group objects to be monitored, here it is also possible to monitor a physical device input instead of a group object. This is possible because the correct function of the temperature input is imperative for the correct function of the device. For the monitoring to work, the related input must also be parameterized as a temperature sensor and a temperature sensor must be connected to it. This setting is specified in the parameter window for the related input. So that the temperature sensor connected also has an effect on the controller, the sensor must also be assigned to the controller in the Application parameters parameter window in the Temperature input parameter by selecting the corresponding options (Via physical device input or Via physical device input and group object).

Monitoring of one of the physical inputs is not allowed if Temperature input - Via group object has been selected in the controller. This will result in the monitoring time being exceeded, because the device inputs are monitored using very short times.

- Deactivated: The monitoring of the temperature input is deactivated.
- On physical device input a/b: The temperature sensor connected to the input selected is monitored. If the input does not deliver a valid temperature value for more than a minute, the fault value parameterized is used. The Control value on input fault

dependent parameter is displayed.

- On group object: The External temperature 1 and External temperature 2 (only if activated) group objects are monitored. As soon as a new value is received in one of the two group objects, the monitoring time for the related group object starts again. The dependent parameters Time interval for cyclical monitoring and Control value after exceeding monitoring time as well as the Fault: actual temperature (master) group object are enabled



Note: For the monitoring to work, the related input must also be parameterized as a temperature sensor and a temperature sensor must be connected to it. This setting is specified in the parameter window for the related input. So that the temperature sensor connected also has an effect on the controller, the sensor must also be assigned to the controller in the Application parameters parameter window in the Temperature input parameter by selecting the corresponding options (Via physical device input or Via physical device input and group object). Monitoring of one of the physical inputs is not allowed if Temperature input - Via group object has been selected in the controller. This will result in the monitoring time being exceeded, because the device inputs are monitored using very short times. It is necessary that a value is received in both group objects within the monitoring time to prevent the triggering of the cyclical monitoring.

13.2.228 Monitoring and Safety - Time interval for cyclical monitoring

| | |
|---------|----------------------|
| Options | 00:00:30 to 18:12:15 |
|---------|----------------------|

The monitoring time within which the group object must be received is specified using this parameter. Otherwise the Error: operating mode receipt alarm object is changed to alarm and the value set in the Operating mode after exceeding monitoring time parameter applies.



Note: Temperature monitoring input parameter has been activated as "On group object"

13.2.229 Monitoring and Safety - Control value after exceeding monitoring time / Control value on input fault

| | |
|---|------------|
| Control value after exceeding monitoring time | 0 to 100 % |
| Control value on input fault | 0 to 100 % |

The name of the parameter is dependent on whether the group objects or a physical input is monitored as the temperature input. The control value specified here becomes active if the monitoring time is exceeded or if there is an error on the device input monitored. The control value applies to heating or cooling, depending on which was active at the time of the alarm. In addition, the device changes to the Building Protection operating mode. The monitoring of the temperature value is important because the controller cannot calculate any control values for the outputs without a valid room temperature value. To protect the system, using this parameter it is possible to specify a certain control value to prevent, e.g., cooling of the room. The control value set here remains active until the error on the input has been rectified or a new temperature value has been received via the bus. If a physical device input is monitored, the device automatically checks every minute whether the

input is signaling an error. If this is the case, the device changes to the control value set. For this reason, it is not necessary to specify a time for monitoring an input.



Note: This parameter is only visible if the Temperature input monitoring parameter has not been deactivated

13.2.230 Monitoring and Safety - Monitor receipt of group object
 "Operating mode"

| | |
|---------|--------------------------|
| Options | Deactivated Activated |
|---------|--------------------------|

The monitoring of the Operating mode group object is activated using this parameter. The regular changeover of the operating mode can be monitored using this parameter. Because this changeover is generally triggered by a higher-level device, such as a visualization or building control system, it is therefore also monitored whether the higher-level device is active.

- Deactivated: The monitoring of the Operating mode group object is deactivated.
- Activated: The monitoring of the group object is active. The dependent parameters Time interval for cyclical monitoring and Operating mode after exceeding monitoring time as well as the Error: operating mode receipt group object are enabled.

13.2.231 Monitoring and Safety - Time interval for cyclical monitoring

| | |
|---------|----------------------|
| Options | 00:00:30 to 18:12:15 |
|---------|----------------------|

The monitoring time within which the group object must be received is specified using this parameter. Otherwise the Error: operating mode receipt alarm object is changed to alarm and the value set in the Operating mode after exceeding monitoring time parameter applies.



Note: This parameter is only visible if the temperature monitor receipt of group object "Operating mode" is activated

13.2.232 Monitoring and Safety - Operating mode after exceeding monitoring time

| | |
|---------|--|
| Options | Comfort Standby Economy Building protection |
|---------|--|

The selection made here defines which operating mode is to apply on the erroneous reception of the Operating mode group object. This mode remains active until a new value is received in the group object monitored.



Note: This parameter is only visible if the temperature monitor receipt of group object "Operating mode" is activated

13.2.233 Monitoring and Safety - Monitor receipt of group object "Toggle heating/cooling"

| | |
|---------|--------------------------|
| Options | Deactivated Activated |
|---------|--------------------------|

The monitoring of the Heating/Cooling changeover group object is enabled using this parameter. The change in the type of operation can be monitored using this parameter.

- Deactivated: The monitoring of the Heating/Cooling changeover group object is deactivated.
- Activated: The monitoring of the group object is active. The dependent parameters Time interval for cyclical monitoring and Heating/cooling mode when monitoring time exceeded as well as the Error: heating/cooling receipt group object are enabled.



Note: The parameter is only visible if in the Heating/Cooling changeover parameter in the Application parameters parameter window, Via object only or Via On/Off button and slave and object has been selected.

13.2.234 Monitoring and Safety - Time interval for cyclical monitoring

| | |
|---------|----------------------|
| Options | 00:00:30 to 18:12:15 |
|---------|----------------------|

The monitoring time within which the group object must be received is specified using this parameter. Otherwise the Error: heating/cooling receipt alarm object is changed to alarm and the value set in the Heating/cooling mode when monitoring time exceeded parameter applies.



Note: This parameter is only visible if the monitor receipt of group object "Toggle heating/cooling" is activated

13.2.235 Monitoring and Safety - Heating/cooling mode when monitoring time exceeded

| | |
|---------|---------------------------------|
| Options | Unchanged Heating Cooling |
|---------|---------------------------------|

The selection made here defines which type of operation is to apply on the erroneous reception of the Heating/Cooling changeover group object. This type of operation remains active until a new value is received in the group object monitored. If the Unchanged option is selected, the current type of operation remains active.



Note: This parameter is only visible if the monitor receipt of group object "Toggle heating/cooling" is activated

13.2.236 Monitoring and Safety - Monitor receipt of group object "Window contact"

| | |
|---------|--------------------------|
| Options | Deactivated Activated |
|---------|--------------------------|

The monitoring of the Window contact group object is activated using this parameter. The regular reception of the window status can be monitored using this parameter.

- Deactivated: The monitoring of the Window contact group object is deactivated.
- Activated: The monitoring of the group object is active. The dependent parameter Time interval for cyclical monitoring and the Error: window status receipt group object are enabled.



Note: This parameter is only visible if the Via group object option has been selected for the Window status input parameter in the Application parameters parameter window.

13.2.237 Monitoring and Safety - Time interval for cyclical monitoring

| | |
|---------|----------------------|
| Options | 00:00:30 to 18:12:15 |
|---------|----------------------|

The monitoring time within which the group object must be received is specified using this parameter. Otherwise the Error: window status receipt alarm object is changed to alarm and the controller reacts as if the window were open. This means that the controller changes over to the Building Protection mode. This mode remains active until a new value is received in the group object monitored.



Note: This parameter is only visible if the monitor receipt of group object "Window contact" is activated

13.2.238 Monitoring and Safety - Monitor receipt of group object "Dew point alarm"

| | |
|---------|--------------------------|
| Options | Deactivated Activated |
|---------|--------------------------|

The monitoring of the Dew point alarm group object is activated using this parameter. The regular reception of the dew point alarm can be monitored using this parameter.

- Deactivated: The monitoring of the Dew point alarm group object is deactivated.
- Activated: The monitoring of the group object is active. The dependent parameter Time interval for cyclical monitoring and the Error: dew point status receipt group object are enabled.



Note: This parameter is only visible if the Via group object option has been selected for the Dew point status input parameter in the Application parameters parameter window.

13.2.239 Monitoring and Safety - Time interval for cyclical monitoring

| | |
|---------|----------------------|
| Options | 00:00:30 to 18:12:15 |
|---------|----------------------|

The monitoring time within which the group object must be received is specified using this parameter. Otherwise the Error: dew point status receipt alarm object is changed to alarm and the controller reacts as if the dew point alarm were active. This means that the controller changes to the Building Protection operating mode, which results in the closing of the cooling output. As long as the fill level alarm is

active, this mode for cooling cannot be left again. This state remains active until a new value is received in the group object monitored that clears the alarm. If the device is changed to the heating mode (on a device that is used for heating and cooling), the device continues to function as before, without the alarm having any effect, because the alarm only relates to cooling.



Note: This parameter is only visible if the monitor receipt of group object "Dew point alarm" is activated

13.2.240 Monitoring and Safety - Monitor receipt of group object "Fill level alarm"

| | |
|---------|--------------------------|
| Options | Deactivated Activated |
|---------|--------------------------|

The monitoring of the Fill level alarm group object is activated using this parameter. The regular reception of the fill level alarm can be monitored using this parameter.

- Deactivated: The monitoring of the Fill level alarm group object is deactivated.
- Activated: The monitoring of the group object is active. The dependent parameter Time interval for cyclical monitoring and the Error: fill level status receipt group object are enabled.



Note: This parameter is only visible if the Via group object option has been selected for the fill level alarm input parameter in the Application parameters parameter window.

13.2.241 Monitoring and Safety - Time interval for cyclical monitoring

| | |
|---------|----------------------|
| Options | 00:00:30 to 18:12:15 |
|---------|----------------------|

The monitoring time within which the group object must be received is specified using this parameter. Otherwise the Error: fill level status receipt group object is changed to alarm and the controller reacts as if the fill level alarm were active. This means that the controller sets the control value for cooling to 0. As long as the dew point alarm is active, this control value for cooling cannot be raised again. This state remains active until a new value is received in the group object monitored that clears the alarm. If the device is changed to the heating mode (on a device that is used for heating and cooling), the device continues to function as before, without the alarm having any effect, because the alarm only relates to cooling.



Note: This parameter is only visible if the monitor receipt of group object "Fill level alarm" is activated

13.2.242 Valve A

13.2.243 On/Off version - Valve output

| | |
|---------|--|
| Options | Motor-driven (3-point) Open/Close signal Deactivated |
|---------|--|

This parameter defines the type of valve that is connected to the output. The control values received (from the internal controller or via the bus) at the valve are converted to the correct output signal depending on the valve type selected. The dependent group objects Status byte valve A, Status Control value and Fault: valve output are displayed as long as the output is not deactivated. In addition, the parameter defines whether the valve outputs for A and B are parameterized separately or together. If Open/Close signal is selected, A and B are two separate channels. If the Motor-driven (3-point) option is selected, the channels for the actuation of the valve are combined and parameterized in channel A. The control value is assigned to the valve in the Application – Application parameters parameter window. Here it is defined which control value from the controller is to be output on which valve output. If a control value has been assigned to the valve in the Application – Application parameters parameter window, this control value is not output if the output is deactivated.

- Motor-driven (3-point): If this option is selected, valve outputs A and B are combined to make it possible to actuate a motor-driven valve drive. Here output A is used to output the opening signal and output B to output the closing signal.
- Open/Close signal: With this selection, the continuous control value is converted into an OPEN or CLOSE signal from a parameterized value. The parameter for entering the threshold value is displayed.
- Deactivated: The output is deactivated.

13.2.244 On/Off version - Selection of Motor-driven (3-point)

13.2.245 On/Off version - Reversing time

| | |
|---------|---------------|
| Options | 50 to 1000 ms |
|---------|---------------|

This parameter defines the reversing delay time of the valve drive. The technical data for the valve drive must be observed.



Note: This parameter is only visible if the Valve output Motor-driven (3-point) is activated

13.2.246 On/Off version - Switch on time for valve drive from 0 to 100 %

| | |
|---------|---------------|
| Options | 10 to 6000 ms |
|---------|---------------|

This parameter sets the time that the output switches on to move the valve drive or the valve from 0 % (closed) to position 100 % (fully opened). The time required should be taken from the technical data of the valve.



Note: This parameter is only visible if the Valve output Motor-driven (3-point) is activated

13.2.247 On/Off version - Automatic adjustment of valve drive

| | |
|---------|-----------|
| Options | No Yes |
|---------|-----------|

If the control value 0% is only rarely achieved in ongoing operation, this can lead to inaccuracies in positioning control. This parameter activates automatic adjustment to

move the valve drive in a defined manner to the 0% position. This serves as the basis for position adjustment.

- Yes: Automatic adjustment is activated. The dependent parameter Number of changes until adjustment is displayed.
- No: Automatic adjustment is deactivated.



Note: This parameter is only visible if the Valve output Motor-driven (3-point) is activated

13.2.248 On/Off version - Number of changes until adjustment

| | |
|---------|--------------|
| Options | 30 to 65,535 |
|---------|--------------|

The output is only actuated if the calculated change in the valve position (based on the opening time for the drive and the change in the control value) is greater than one second. This condition prevents small position changes and protects the drive against unnecessary movements. The wear on the drive is reduced.

This parameter determines the number of valve controls after which automatic adjustment is to be triggered. The adjustment counter is incremented by 1 at the end of a drive adjustment. If the parameterized number of valve controls is reached, the reference adjustment is started. The closed position is then moved past by 5 % of the parameterized switch on time based on the last control value for the valve drive (at least 1 second, not more than 60 seconds). This function cannot be interrupted. Thereafter, the currently calculated control value is approached, and the adjustment counter is set to zero.

Example:

Switch on time for valve drive from 0 to 100 %: 100 s

Current control value: 50 %

Reference adjustment to 0 %: 50 s + 5 s

50 s = normal movement time from 50 % to 0 % + 5 s = 5 % of 100 s

The following events trigger a reference adjustment:

- 230V recovery
- ETS reset
- Download
- Reset of a remedied fault (via Reset button or via Reset fault on valve output X group object)



Note: This parameter is only visible if the Valve output Motor-driven (3-point) is activated

13.2.249 On/Off version - Selection of Open/Close signal

13.2.250 On/Off version - Valve drive operating principle, de-energized

| | |
|---------|----------------|
| Options | Closed Open |
|---------|----------------|

This parameter determines the function of the valve drive.

- Closed: If no current flows in the valve drive, the valve is closed. If current flows in the valve drive, the valve opens.
- Open: If no current flows in the valve drive, the valve opens. If current flows in the valve drive, the valve then closes.



Note: This parameter is only visible if the Valve output Open/Close signal is activated

13.2.251 On/Off version - Open if control value greater than or equal to

| | |
|---------|-----------|
| Options | 1 to 100% |
|---------|-----------|

The output switches ON continuously if the value parameterized here is greater than or equal to the received control value. If a control value less than the parameterized value is received, the output switches OFF.



Note: This parameter is only visible if the Valve output Open/Close signal is activated

13.2.252 On/Off version - Valve drive opening/closing time

| | |
|---------|-------------|
| Options | 10 to 900 s |
|---------|-------------|

With this parameter, a time is set in seconds that the connected valve requires to move from position 0 % (valve closed) to position 100 % (valve fully open), or the valve requires to move from 100 % to 0 %. The time should be taken from the technical data of the valve, and it corresponds with the total runtime.



Note: This parameter is only visible if the Valve output Open/Close signal is activated

13.2.253 On/Off version - Send status values

| | |
|---------|---|
| Options | On change Cyclically On request After a change or on request After a change or request and cyclically |
|---------|---|

This parameter defines when the valve output status value are to be sent. It affects the group objects Status byte valve A, Fault: valve output A and Status Control value for the valve drive.

- On change: The values are sent on a change in the object values (e.g. change from 0 to 1).
 With the Status Control value group object the values are only sent if the change in the control value is at least 1 %.
- Cyclically: If this option is selected, the status values are sent automatically after an adjustable time has elapsed. The Every dependent parameter is displayed.
- On request: The valve output status values are sent on the receipt of a command via the Request status values group object.
- After a change or request: The values are sent on request and on a change.

- After a change or request and cyclically: The values are sent on request and on a change and cyclically. The Every dependent parameter is displayed.

13.2.254 On/Off version - Every

| | |
|---------|----------------------|
| Options | 00:00:30 to 18:12:15 |
|---------|----------------------|

This parameter is used to set the time after which the status values are to be sent cyclically. The group objects are sent after each cycle.



Note: This parameter is only visible if the send status values "After a change or request and cyclically" is activated

13.2.255 On/Off version - Enable manual valve override

| | |
|---------|-----------|
| Options | No Yes |
|---------|-----------|

Manual valve override is enabled using this parameter. This feature is used to specify valve control values directly; the control value from the controller is overridden. This action may be necessary during the commissioning phase, for example, to test the function of the system. A further possible application is the specific overriding of controller. As soon as the manual override is activated via the Enable/disable manual override valve A group object, the value currently in the Override valve control value group object is written to the valve. If, while the override was disabled, a value was written to this group object, this value will become active as soon as the override is enabled.

- No: The manual valve override is deactivated
- Yes: The manual override is enabled. The two group objects Enable/disable manual override valve A and Override valve control value are enabled. The former is used to activate or deactivate the manual override. The manual valve control value is specified using the second group object. Only if the manual override has been activated via the first group object is the value in the second group object sent to the valve. As soon as the manual override is ended using the Enable/disable manual override valve A group object, the valve output reacts again to the controller (controller mode) or the control values received via the bus (actuator mode).

13.2.256 On/Off version - Valve purge

| | |
|---------|--|
| Options | Deactivated Automatic or triggered by object Triggered by object |
|---------|--|

Valve purging by the device is enabled using this parameter. This parameter is used to trigger a device opening and closing cycle during times when the valve is not in use to prevent the valve from seizing. During the valve purging, the valve is opened completely once and closed again, corresponding to the values set in the Valve drive opening/closing time parameter. The purging cycle time is restarted if automatic valve purging has been activated at start-up of the device. The purging cycle time will be restarted at the end of the actual purging period. The parameterized period of valve purging is included here. The purging cycle with an active automatic valve purge is reset and restarted if:

- A manual valve purge is triggered via the group object Activate purge.
- The parameterized value (in Reset purge cycle from...) is exceeded. The purging cycle is only restarted once the parameterized value is reached or exceeded.
- Deactivated: Valve purging is deactivated.
- Automatic or triggered by object: Valve purging can be triggered via a group object or it occurs automatically after an adjustable time has elapsed. The group objects Status Valve purge and Activate valve purge as well as the parameters Purge cycle in weeks, Reset purge cycle from control value greater than or equal to and Send group object "Status Valve purge" are enabled.
- Triggered by object: The valve purging can be triggered via a group object. The group objects Status Valve purge and Activate valve purge as well as the parameters Reset purge cycle from control value greater than or equal to and Send group object "Status Valve purge" are enabled.

13.2.257 On/Off version - Purge cycle in weeks

| | |
|---------|---------|
| Options | 1 to 12 |
|---------|---------|

The cycle for the automatic valve purging is set using this parameter. The internal automatic purge timer starts directly after a download. The time is reset with each download. The time is reset as soon as purging is completed. This can occur either through automatic purging or via the group object Trigger purge. After 230V recovery and download, the automatic purging cycle is restarted. The time before 230V failure is not considered. If the purge cycle is triggered simultaneously for two valves, the purging is undertaken sequentially and not at the same time.



Note: This parameter is only visible if the Valve purge "Automatic or triggered by object" option has been selected.

13.2.258 On/Off version - Send group object "Status Valve purge"

| | |
|---------|--|
| Options | No, update only On change Cyclically On request After a change or on request After a change or request and cyclically |
|---------|--|

This parameter defines when the Status Valve purge group object is to be sent.

- No, update only: With this option only the object value for the group object is updated, however this value is not sent over the bus.
- On request: The valve purging status value is sent on the receipt of a command via the Request status values group object.
- On change: The value is sent on a change in the object value (e.g. change from 0 to 1).
- Cyclically: If this option is selected, the status value is sent automatically after an adjustable time has elapsed. The Every dependent parameter is displayed.
- After a change or request: The status is sent on request and on a change.
- After a change or request and cyclically: The status is sent on request and on a change and cyclically. The Every dependent parameter is displayed.

13.2.259 On/Off version - Every

| | |
|---------|----------------------|
| Options | 00:00:30 to 18:12:15 |
|---------|----------------------|

This parameter is used to set the time after which the status values are to be sent cyclically. The group objects are sent after each cycle.



Note: This parameter is only visible if the Send group object "Status Valve purge" Cyclically or After a change or request and cyclically is activated

13.2.260 0~10V version - Valve output

| | |
|---------|--|
| Options | Activated Deactivated Use as VAV damper output |
|---------|--|

This parameter defines the type of use of valve output A. The control value is assigned to the valve in the Application – Application parameters parameter window. Here it is defined which control value from the controller is to be output on which valve output. Nevertheless, a control value can still be assigned to the valve in the Application – Application parameters parameter window. Because the output is deactivated, this value is not output. Nevertheless, a control value can still be assigned to the output in the Application – Application parameters parameter window. Although this control value is output, it can cause malfunctions due to the lack of adjustment. In this mode the output behaves like a normal analog output. The control value received via the bus is output directly in the selected output range. There is no further influence from the controller.

- Activated: The output is used as a normal control value for a 0 - 10 V valve. The group objects Status byte valve A, Status Control value, Fault: valve output A and Reset fault on valve output A are displayed. The dependent parameters are displayed.
- Deactivated: The output is deactivated.
- Use as VAV damper output: With this setting the output is used to operate a damper drive using the 0~10 V signal. For this purpose, the parameters and group objects for the valve output are deactivated and instead the group objects Control value VAV damper control A and Status Control value displayed. The dependent parameters Voltage range VAV damper control value and Reaction on bus voltage recovery, ETS download or ETS reset are displayed.

13.2.261 0~10V version - Voltage range valve control value

| | |
|---------|--|
| Options | 0 – 10 V 1 – 10 V 2 – 10 V 10 – 0 V |
|---------|--|

This parameter defines the function of the valve output. Depending on the selection, the control value is converted to the corresponding voltage range. Valve drives closed if de-energized (0...10 V; 1...10 V; 2...10 V): If no current flows in the valve drive, the valve is closed. If current flows in the valve drive, the valve opens. Valve drives opened if de-energized (10...0 V): If no current flows in the valve drive, the valve opens. If current flows in the valve drive, the valve then closes. The technical data for the valve drive must be observed.

On the selection of the 1 – 10 V and 2 – 10 V options, the output voltage is limited to this range. To make sure that the valve is always closed completely, on the actuation of the valve with 0 % (= closed), the control value 0 V is output nevertheless. If the control value is greater than 0 %, the lower limit (1 V or 2 V) is used directly for the actuation. If the DPT 5.001 (percent) is used for actuation, the value of the group object may be displayed as 0 %, but the actual value of the group object may be slightly above that and a 0 is only displayed due to the rounding to integer values. This situation can be detected by viewing the hexadecimal value (this is then e.g. 0x0001) or changing to a different DPT (e.g. 5.005).



Note: This parameter is only displayed if the Valve type parameter is parameterized with the Normal option

13.2.262 0~10V version - 6-way valve type

This parameter indicates whether the valve output is a normal output, or this output is used to actuate a 6-way valve. This parameter can be changed using the Use 6-way valve parameter in the Application – Application parameters parameter window.

- Normal: This option is set if the Use 6-way valve is parameterized with the No option.
- 6-way valve: This option is set if the Use 6-way valve is parameterized with the Yes option.

On use as a 6-way valve, the valve output is used for heating and for cooling. The special layout of the 6-way valve makes it possible to use both pipes independent of each other. To safeguard this functionality, the drive control value is divided into a range for cooling and a range for heating. Between these ranges there is a dead zone in which the valve is closed. If the control value is in the actuation range for cooling, the flow for cooling is opened corresponding to the control value and the flow for heating shut off. The same applies vice versa. The following illustration shows the relationship between voltage range and control value. The following example values have been selected:

- Voltage for maximum cooling: 2 V
- Voltage for minimum cooling: 5 V
- Voltage for maximum heating: 7 V
- Voltage for minimum heating: 10 V

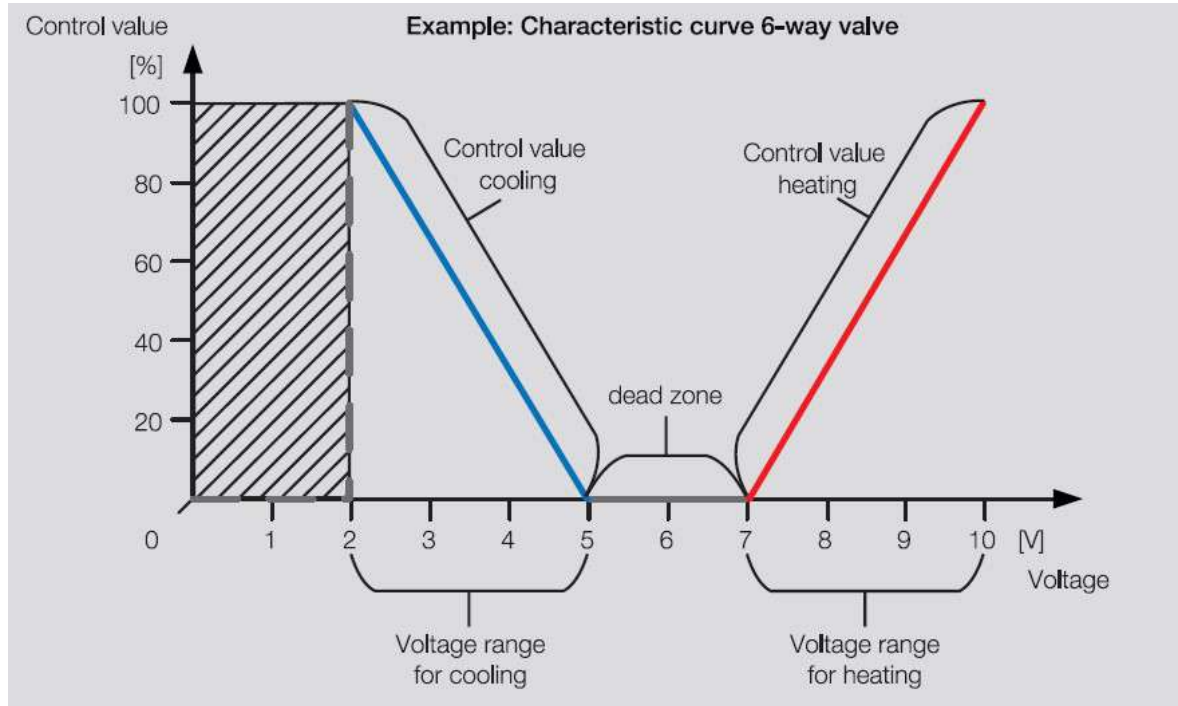

6-way valve

13.2.263 6-way valve type - Voltage range for cooling

13.2.264 6-way valve type - Voltage for maximum cooling

| | |
|---------|----------|
| Options | 0 – 10 V |
|---------|----------|

This parameter is used to specify the lower limit for the voltage range for the output of the cooling control value.



Note: This parameter is only displayed if the Valve type parameter is parameterized with the 6-way valve.

13.2.265 6-way valve type - Voltage for minimum cooling/cooling valve closed

| | |
|---------|----------|
| Options | 0 – 10 V |
|---------|----------|

This parameter is used to specify the lower limit for the voltage range for the output of the heating control value.



Note: This parameter is only displayed if the Valve type parameter is parameterized with the 6-way valve.

13.2.266 6-way valve type - Voltage for minimum heating/heating valve closed

| | |
|---------|----------|
| Options | 0 – 10 V |
|---------|----------|

This parameter is used to specify the lower limit for the voltage range for the output of the heating control value.



Note: This parameter is only displayed if the Valve type parameter is parameterized with the 6-way valve.

13.2.267 6-way valve type - Voltage for maximum heating

| | |
|---------|----------|
| Options | 0 – 10 V |
|---------|----------|

This parameter is used to specify the upper limit for the voltage range for the output of the heating control value.



Note: This parameter is only displayed if the Valve type parameter is parameterized with the 6-way valve.

13.2.268 6-way valve type - Valve drive opening/closing time

| | |
|---------|-------------|
| Options | 10 to 900 s |
|---------|-------------|

With this parameter, a time is set in seconds that the connected valve requires to move from position 0 % (valve closed) to position 100 % (valve fully open), or the valve requires to move from 100 % to 0 %. The time should be taken from the technical data of the valve, and it corresponds with the total runtime.

13.2.269 0~10V version - Voltage range VAV damper control value

| | |
|---------|--------------------------------------|
| Options | 0~10 V 1~10 V 2~10 V 10~0 V |
|---------|--------------------------------------|

This parameter defines the function of the damper control value. Depending on the selection, the control value is converted to the corresponding voltage range. On the selection of the 1 - 10 V and 2 - 10 V options, the output voltage is limited to this range. To make sure that the damper is always closed completely, on the actuation of the output with 0 % (= closed), the control value 0 V is output nevertheless. If the control value is greater than 0 %, the lower limit (1 V or 2 V) is used directly for the actuation. If the DPT 5.001 (percent) is used for the actuation, the value of the group object may be displayed as 0 %, but the actual value of the group object may be slightly above that and a 0 is only displayed due to the rounding to integer values. This situation can be detected by viewing the hexadecimal value (this is then e.g. 0x0001) or changing to a different DPT (e.g. 5.005).



Note: This parameter is visible if the Use as VAV damper output option has been selected in the Valve output parameter and the output is used as a valve output.

13.2.270 0~10V version - Send status values

| | |
|---------|---|
| Options | On change Cyclically On request After a change or on request After a change or request and cyclically |
|---------|---|

This parameter defines when the valve output status value are to be sent. It affects the group objects Status byte valve A, Fault: valve output A and Status Control value for the valve drive.

- On change: The value is sent on a change to the control value if the change in the control value is at least 1 %.
- Cyclically: If this option is selected, the status value is sent automatically after an adjustable time has elapsed. The Every dependent parameter is displayed.
- On request: The status value is sent on the receipt of a command via the Request status values group object.
- After a change or request: The value is sent on request and on a change.
- After a change or request and cyclically: The value is sent on request and on a change and cyclically. The Every dependent parameter is displayed.

13.2.271 0~10V version - Every

| | |
|---------|----------------------|
| Options | 00:00:30 to 18:12:15 |
|---------|----------------------|

This parameter is used to set the time after which the status values are to be sent cyclically. The group objects are sent after each cycle.



Note: This parameter is visible if Send status values is selected as "Cyclically, After a change or request and cyclically".

13.2.272 0~10V version - Enable manual valve override

| | |
|---------|-----------|
| Options | No Yes |
|---------|-----------|

Manual valve override is enabled using this parameter. This feature is used to specify valve control values directly; the control value from the controller is overridden. This action may be necessary during the commissioning phase, for example, to test the function of the system. A further possible application is the specific overriding of controller. As soon as the manual override is activated via the Enable/disable manual override valve A group object, the value currently in the Override valve control value group object is written to the valve. If, while the override was disabled, a value was written to this group object, this value will become active as soon as the override is enabled.

- No: The manual valve override is deactivated
- Yes: The manual override is enabled. The two group objects Enable/disable manual override valve A and Override valve control value are enabled. The former is used to activate or deactivate the manual override. The manual valve control value is specified using the second group object. Only if the manual override has been activated via the first group object is the value in the second group object sent to the valve. As soon as the manual override is ended using the Enable/disable manual override valve A group object, the valve output reacts again to the controller (controller mode) or the control values received via the bus (actuator mode).

13.2.273 0~10V version - Valve purge

| | |
|---------|--|
| Options | Deactivated Automatic or triggered by object Triggered by object |
|---------|--|

Valve purging by the device is enabled using this parameter. This parameter is used to trigger a device opening and closing cycle during times when the valve is not in use to prevent the valve from seizing. During the valve purging, the valve is opened completely once and closed again, corresponding to the values set in the Valve drive opening/closing time parameter. The purging cycle time is restarted if automatic valve purging has been activated at start-up of the device. The purging cycle time will be restarted at the end of the actual purging period. The parameterized period of valve purging is included here. The purging cycle with an active automatic valve purge is reset and restarted if:

- A manual valve purge is triggered via the group object Activate purge.
- The parameterized value (in Reset purge cycle from...) is exceeded. The purging cycle is only restarted once the parameterized value is reached or exceeded.
- Deactivated: Valve purging is deactivated.
- Automatic or triggered by object: Valve purging can be triggered via a group object or it occurs automatically after an adjustable time has elapsed. The group objects Status Valve purge and Activate valve purge as well as the parameters Purge cycle in weeks, Reset purge cycle from control value greater than or equal to and Send group object "Status Valve purge" are enabled.
- Triggered by object: The valve purging can be triggered via a group object. The group objects Status Valve purge and Activate valve purge as well as the parameters Reset purge cycle from control value greater than or equal to and Send group object "Status Valve purge" are enabled.

13.2.274 0~10V version - Purge cycle in weeks

| | |
|---------|---------|
| Options | 1 to 12 |
|---------|---------|

The cycle for the automatic valve purging is set using this parameter. The internal automatic purge timer starts directly after a download. The time is reset with each download. The time is reset as soon as purging is completed. This can occur either through automatic purging or via the group object Trigger purge. After 230V recovery and download, the automatic purging cycle is restarted. The time before 230V failure is not considered. If the purge cycle is triggered simultaneously for two valves, the purging is undertaken sequentially and not at the same time.



Note: This parameter is only visible if the Valve purge "Automatic or triggered by object" option has been selected.

13.2.275 0~10V version - Reset purge cycle from control value greater than or equal to

| | |
|---------|----------|
| Options | 1 to 99% |
|---------|----------|

Hereby, the purge cycle is reset to the set control value if it is exceeded.



Note: This parameter is only visible if the Valve purge "Automatic or triggered by object" option has been selected.

13.2.276 0~10V version - Send group object "Status Valve purge"

| | |
|---------|--|
| Options | No, update only On change Cyclically On request After a change or on request After a change or request and cyclically |
|---------|--|

This parameter defines when the Status Valve purge group object is to be sent.

- No, update only: With this option only the object value for the group object is updated, however this value is not sent over the bus.
- On request: The valve purging status value is sent on the receipt of a command via the Request status values group object.
- On change: The value is sent on a change in the object value (e.g. change from 0 to 1).
- Cyclically: If this option is selected, the status value is sent automatically after an adjustable time has elapsed. The Every dependent parameter is displayed.
- After a change or request: The status is sent on request and on a change.
- After a change or request and cyclically: The status is sent on request and on a change and cyclically. The Every dependent parameter is displayed.

13.2.277 0~10V version - Every

| | |
|---------|----------------------|
| Options | 00:00:30 to 18:12:15 |
|---------|----------------------|

This parameter is used to set the time after which the status values are to be sent cyclically. The group objects are sent after each cycle.



Note: This parameter is only visible if the Send group object "Status Valve purge" Cyclically or After a change or request and cyclically is activated

13.2.278 VAV damper - Reaction on 230V recovery, ETS download and ETS reset

| | |
|---------|---------------------|
| Options | Unchanged Select |
|---------|---------------------|

- Unchanged: If this option is selected, after bus voltage recovery and ETS download the output provides the same voltage as before the event.
- Select: If this option is selected, it is possible to set the output voltage after bus voltage recovery and ETS download in the Control value parameter.

13.2.279 VAV damper - Control value

| | |
|---------|-----------|
| Options | 0 to 100% |
|---------|-----------|

This parameter is used to specify the control value that is to be set after bus voltage recovery, ETS download and ETS reset. The value set after bus voltage recovery, ETS download and ETS reset applies until a new control value is received via the Control value VAV damper control A group object.



Note: This parameter is visible if Reaction on bus voltage recovery, ETS download and ETS reset is set as "Select".

13.2.280 VAV damper - Send status values

| | |
|---------|---|
| Options | On request On change Cyclically After a change or on request After a change or request and cyclically |
|---------|---|

This parameter defines when the Status Control value for the VAV damper output is to be sent.

- On request: The status value is sent on the receipt of a command via the Request status values group object.
- On change: The value is sent on a change to the control value if the change in the control value is at least 1 %.
- Cyclically: If this option is selected, the status value is sent automatically after an adjustable time has elapsed. The Every dependent parameter is displayed.
- After a change or request: The value is sent on request and on a change.
- After a change or request and cyclically: The value is sent on request and on a change and cyclically. The Every dependent parameter is displayed.

13.2.281 VAV damper - Every

| | |
|---------|----------------------|
| Options | 00:00:30 to 18:12:15 |
|---------|----------------------|

This parameter is used to set the time after which the status values are to be sent cyclically. The group objects are sent after each cycle.



Note: This parameter is visible if Send status values is selected as "Cyclically, After a change or request and cyclically".

13.2.282 Valve B

For On/Off version. The parameters for valve output B are the same as for valve output A. The only exception is the parameterization of valve output A for a motor-driven valve drive (3-point). In this case the parameters for valve output B are deactivated because the valve output is then used to output the closing signal for the 3-point drive. If Electric heater (in room) or Fan coil unit: electric heater (in fan coil unit) function is selected in Application parameters: basic-stage heating or additional-stage heating, valve B parameter need to be deactivated and output of electric heater parameter will be configured in Electric heater relay output

For 0~10V version. The parameters for valve output B are the same as for valve output A. The only exception is the parameterization of valve output A for a 6-way valve. This setting cannot be made for output B. As such the Valve type parameter is always set to the Normal option.

13.2.283 Fan output

13.2.284 Fan output - Number of fan speeds

| | |
|---------|--------|
| Options | 1 2 |
|---------|--------|

| | |
|--|---|
| | 3 |
|--|---|

This parameter is used to define how many fan speeds the fan actuated has. If the fan has only 1 or 2 speeds, the output is correspondingly only on 1 or 2 relay outputs. The relay for the 3rd or the 2nd and 3rd speeds is not used in this situation.

13.2.285 Fan output - Fan type of operation (important: observe the technical data for the fan)

| | |
|---------|---------------------------|
| Options | Changeover Step switch |
|---------|---------------------------|

Control of the fan is set with this parameter. The mode of fan control should be taken from the technical data of the fan.

With changeover switch control, only the corresponding output for the assigned fan speed is switched on. The delay time between the speed switchover and a minimum dwell time can be parameterized. The latter is only active in automatic operation.

With step switch control, it is impossible for the fan to switch on erratically or suddenly. The individual fan speeds are activated consecutively (outputs switched on) until the required fan speed is reached. The parameterized delay time between two fan speeds has the effect that the current fan speed must be switched on for at least this time before the next speed is switched on. The parameterized minimum dwell time has the same effect as a changeover switch, i.e. it is only active in automatic mode and is added to the switchover delay.

13.2.286 Fan output - Delay between fan speed switchover

| | |
|---------|---------------|
| Options | 50 to 5000 ms |
|---------|---------------|

A switchover delay can be programmed with this parameter. This time is a fan-specific factor and it is always taken into account.



Note: This parameter is only visible if the Fan type of operation (important: observe the technical data for the fan) "Changeover" is activated

13.2.287 Fan output - Enable automatic mode based on control value

| | |
|---------|-----|
| Options | Yes |
|---------|-----|

This parameter is used to enable automatic fan operation depending on the control value. In this mode the fan automatically follows the control value for the heating/cooling mode currently active. This means that the higher the control value is, the greater the fan speed is as well. Automatic control is always enabled in the controller mode and cannot be completely deactivated. The purpose of this feature is to ensure the correct function of the device, because otherwise the device would only react to manual adjustment. If the device is used such that both a basic stage and an additional stage (e.g. heating) are in one fan coil unit, in the automatic mode the fan only follows the control value for the basic stage. If the additional stage is in a dedicated fan coil unit, this situation can be addressed by activating the automatic mode in the device used there and using the control value for this device.

- Yes: Automatic operation is activated. The group objects Activate/deactivate fan automation and Status Fan automatic are enabled. The dependent parameters are displayed.

The device evaluates threshold values in ascending order, i.e. first it checks the threshold value for Off <-> Fan speed 1, then Fan speed 1 <-> Fan speed 2, and so on. Proper functionality is only assured if the threshold value for OFF <-> Fan speed 1 is less than that for Fan speed 1 <-> Fan speed 2 and this is less than Fan speed 2 <-> Fan speed 3, etc.

13.2.288 Fan output - Threshold value speed 0 <-> 1

| | |
|---------|----------|
| Options | 0 to 10% |
|---------|----------|

Here the threshold value, at which switch on of fan speed 1 occurs, is set. If the value in the group object Control value is greater than or equal to the parameterized threshold value, fan speed 1 is switched on. If the value is smaller, then it is switched off. If the value is set 0, the fan is only shut down with the control value 0. As soon as the control value is greater than 0, speed 1 is used. To make sure that the valves are not opened too wide without the fan running, only 10 % can be set here as the maximum value

13.2.289 Fan output - Threshold value speed 1 <-> 2

| | |
|---------|-----------|
| Options | 1 to 100% |
|---------|-----------|

This sets the threshold value at which switch over to fan speed 2 occurs. If the value in the group object Control value is greater than or equal to the parameterized threshold value, switch over to fan speed 2 occurs.

13.2.290 Fan output - Threshold value speed 2 <-> 3

| | |
|---------|-----------|
| Options | 1 to 100% |
|---------|-----------|

This sets the threshold value at which switchover to fan speed 3 occurs. If the value in the group object Control value heating or Control value cooling is greater than or equal to the parameterized threshold value, switchover to fan speed 3 occurs.

13.2.291 Fan output - Threshold values hysteresis

| | |
|---------|----------|
| Options | 0 to 20% |
|---------|----------|

This sets a hysteresis at which switchover to the next fan speed occurs. The hysteresis applies to all three threshold values.

The setting 0 causes immediate switching without hysteresis. The entered percentage value is directly added to or subtracted from the percentage value of Threshold value speed x. The result is a new upper or lower threshold value. Switch threshold top (switch on) = threshold value + hysteresis Switch threshold bottom (switch off) = threshold value - hysteresis. The hysteresis does not apply to switching between speeds 0 and 1.

Example: Three-speed fan, fan control with hysteresis

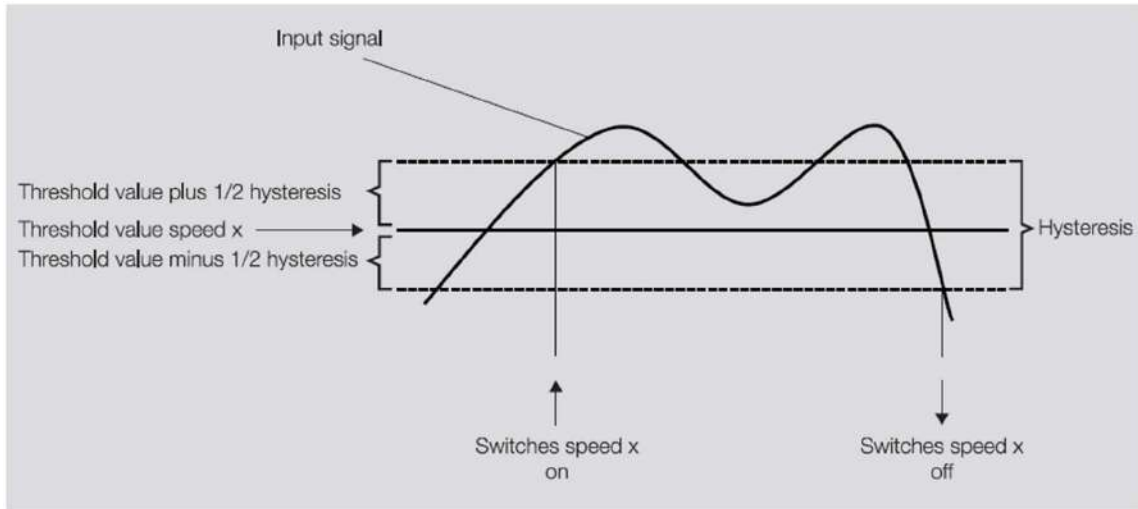

Fan control with hysteresis

Using hysteresis avoids continual switching between the fan speeds caused by fluctuating input signals around the threshold value.

Behavior of the fan with overlapping switching thresholds due to usage of hysteresis

- 1) The hysteresis defines the speed at which the speed set is left.
- 2) If the speed is left, the new speed is determined using the control value and the switching thresholds. The hysteresis is not taken into account. Control values are rounded to whole percentages by the device.
- 3) A control value with the value 0 always results in speed 0.

Example 1:

Parametrized:

Threshold OFF \leftrightarrow Speed 1 = 10 %

Threshold Speed 1 \leftrightarrow Speed 2 = 20 %

Threshold Speed 2 \leftrightarrow Speed 3 = 30 %

Hysteresis 15 %

Behavior when ascending from speed 0:

- Speed 0 is left at 25 % ($\geq 10 \% + \text{hysteresis}$).
- The new speed is 2 (25 % is between 20 % and 30 %).
- Accordingly, speed 1 is omitted.

Behavior when descending from speed 3:

- Speed 3 transition at 14 % ($< 30 \% - \text{hysteresis}$).
- The new speed is 1 (15 % is between 10 and 20 %).
- Accordingly, speed 2 is omitted.

If a switching point is less than or equal to the changeover point 1 \leftrightarrow 0, the speed is skipped on switching down.

Example 2:

Parametrized:

Threshold OFF \leftrightarrow Speed 1 = 1 %

Threshold Speed 1 \leftrightarrow Speed 2 = 10 %

Threshold Speed 2 \leftrightarrow Speed 3 = 20 %

Hysteresis 20%

Behavior when descending from speed 3:

- Speed 3 is left at 20 % (40 % - hysteresis)
- New speed is 2
- Speed 2 is left at 0 % (20 % - hysteresis)
- New speed is 0, speed 1 is skipped

At a speed of 100 %, the highest fan speed is always used. This feature is intended to prevent undesirable incorrect behavior due to erroneous programming

13.2.292 Fan output - Minimum holding time at fan speed

| | |
|---------|------------|
| Options | 0 to 600 s |
|---------|------------|

This parameter defines the dwell time for a fan speed until it switches to the next higher or lower fan speed. The entry is made in seconds. A setting of 0 means instant switching. The minimum relay switching times can be found in the technical data. The dwell time is only taken into account in automatic operation.

13.2.293 Fan output - Return from manual fan adjustment to automatic mode

| | |
|---------|--|
| Options | Via group object Automatic (time) Via group object or automatic (time) |
|---------|--|

This parameter is used to define how a return from manual fan adjustment to the automatic mode is to occur.

- Via group object: The return to the automatic mode is only via the Activate/deactivate fan automation group object.
- Automatic (time): The return is automatic after an adjustable time. The dependent parameter Reset time appears.
- Via group object or automatic (time): The reset is both via the Activate/deactivate fan automation group object and after an adjustable time. The dependent parameter Reset time appears.

13.2.294 Fan output - Reset time

| | |
|---------|----------------------|
| Options | 00:00:30 to 18:12:15 |
|---------|----------------------|

After the time specified here has elapsed, the fan returns to automatic operation. The time starts again after each manual adjustment of the fan.

13.2.295 Fan output - Enable start-up behavior (switch on from Off to On)

| | |
|---------|-----------|
| Options | No Yes |
|---------|-----------|

This parameter enables the fan to start from the OFF state with a defined fan speed. This fan speed is immediately applied. In order to guarantee a safe start of the fan motor, it can be useful to start the fan motor first with a higher fan speed. Thus a higher torque for the start-up phase of the fan is achieved. However, with a step switch, this would mean switching through the other fan speeds consecutively. With the changeover switch the fan speed is switched on right away. The delay between the switchover of two fan speeds (contact change) is taken into account. The dwell times, which are taken into account in automatic operation, are inactive and will only be taken into account after the start-up phase. The start-up behavior is a technical

characteristic of the fan. For this reason, this behavior has a higher priority than an active limitation or forced operation.

- Yes: The dependent parameters Switch on at fan speed and Minimum holding time at switch-on speed are displayed.

13.2.296 Fan output - Switch on at fan speed

| | |
|---------|-------------|
| Options | 1 2 3 |
|---------|-------------|

Here you set which speed the fan uses to start from the OFF state.



Note: This parameter is available if the Enable start-up behavior (switch on from off to on) "Yes" is activated.

13.2.297 Fan output - Minimum holding time at switch on speed

| | |
|---------|------------|
| Options | 0 to 600 s |
|---------|------------|

This parameter defines the minimum dwell time for one of the switch on speeds.



Note: This parameter is available if the Enable start-up behavior (switch on from off to on) "Yes" is activated.

13.2.298 Fan output - Enable run-on behavior for fan speed reduction

| | |
|---------|-----------|
| Options | No Yes |
|---------|-----------|

This parameter activates a run-on for the fan. If the fan changes to a lower speed, it remains in the previous speed for the parameterized run-on time and only then reduces the speed by one level. If the fan goes through several speed changes, run-on times are executed successively, adding on those times. A run-on time of 0 seconds means that run-on is deactivated. Run-on is executed regardless of where the speed change originates (automatic operation, direct operation, manual procedure, fan switch off).

- Yes: The dependent parameters Run-on speed 1, Run-on speed 2 and Run-on speed 3 are displayed

13.2.299 Fan output - Run-on speed 1

| | |
|---------|------------|
| Options | 0 to 600 s |
|---------|------------|



Note: This parameter is available if the Enable run-on behavior for fan speed reduction "Yes" is activated

13.2.300 Fan output - Run-on speed 2

| | |
|---------|------------|
| Options | 0 to 600 s |
|---------|------------|



Note: This parameter is available if the Enable run-on behavior for fan speed reduction "Yes" is activated

13.2.301 Fan output - Run-on speed 3

| | |
|---------|------------|
| Options | 0 to 600 s |
|---------|------------|



Note: This parameter is available if the Enable run-on behavior for fan speed reduction "Yes" is activated

13.2.302 Fan output - Fan speed limitation

| | |
|---------|--------------------------|
| Options | Deactivated Activated |
|---------|--------------------------|

The fan speed limitation can be used to prohibit certain fan speeds or to freeze the fan at a specific speed.

- Deactivated: The fan speed limitation is deactivated
- Enabled: The fan speed limitation is enabled. The dependent parameters Limitation 1, Limitation 2, Limitation 3 are displayed.

13.2.303 Fan output - Limitation 1, Limitation 2, Limitation 3 have the same parameter

| | |
|--------------|---|
| Limitation 1 | 3, 2, 1, OFF Unchanged OFF 1 1, OFF 2 2, 1 2, 1, OFF 3 3, 2 3, 2, 1 |
| Limitation 2 | 3, 2, 1, OFF Unchanged OFF 1 1, OFF 2 2, 1 2, 1, OFF 3 3, 2 3, 2, 1 |
| Limitation 3 | 3, 2, 1, OFF Unchanged OFF 1 1, OFF 2 2, 1 |

| | |
|--|-----------------------------------|
| | 2, 1, OFF 3 3, 2 3, 2, 1 |
|--|-----------------------------------|

This parameter specifies which fan speed(s) is (are) set, or cannot be exceeded/dropped below, if limitation is active. The limitations apply both in the manual mode and in the automatic mode. The parameterized start-up behavior, which is a technical characteristic of the fan, has a higher priority than a limitation, i.e. if a limitation is activated in fan speed 2 and start-up behavior is parameterized with fan speed 3, the following behavior will result: The fan is in the OFF state and receives a control signal for fan speed 1. First the fan goes to speed 3 (start-up speed), then 2, which is specified via the limitation. Due to the limitation, the actual required fan speed 1 will not be reached. This limitation setting will be apply to local fan speed button control as well.

- No limitation active: Everything is possible.
- Unchanged: The state is retained.
- OFF: Off.
- 1: Limited to speed 1.
- 1, OFF: Limited to speed 1 and off.
- 2: Limited to speed 2.
- 2, 1: Limited to speeds 2 and 1.
- 2, 1, OFF: Limited to speed 2, 1 and off.
- 3: Limited to speed 3.
- 3, 2: Limited to speed 3 and 2.
- 3, 2, 1: Limited to speed 3, 2 and 1.

Three limitations are available. These can be used, e.g., to prohibit speed 3 during the night to reduce the noise. The sequence of the displayed parameters corresponds with their priorities, i.e. the parameter with the highest priority has limitation 1 followed by limitation 2 and 3.

The following points apply to all limitations:

- The limitation need not necessarily apply to one fan speed only. It can also encompass another range of the fan speeds, i.e. only certain fan speeds can be set if the limitation is active. In this way, a limited control is also possible.
- The limitation is activated if a telegram with the value 1 is received on the group object Limitation. The limitation is deactivated if a telegram with the value 0 is received on the group object Limitation.
- If a limitation is activated, the product switches to the parameterized fan speed regardless of the control value. If another fan speed or a speed outside the "limitation range" is set when the limitation is activated, then the required speed or the limit speed of the range is set.
- After limitations are switched off, the fan speed is recalculated and implemented. This means that during limitation, the product operates normally in the background, the outputs are not changed, and implementation only occurs once limitation ends.

They are prioritized according to the listed sequence. The highest priority is assigned to limitation1 and the lowest to limitation 3.

13.2.304 Fan output - Switch fan speed via 1-bit objects

| | |
|---------|-------------|
| Options | Deactivated |
|---------|-------------|

| | |
|--|--|
| | Switch off to active fan speed using "0" only Switch off to any 1-bit fan speed using "0" |
|--|--|

Additional group objects for switching the fan may be enabled using this parameter. Using these objects, it is possible to control the fan speeds using specific 1-bit group objects. The differentiation between the two switch-off variants ("0" on the active group object or irrespective of which group object) is used to cater for the case that the source of the values for the group objects sends cyclically or all 3 group objects are always sent simultaneously. This situation can result in the fan switching on only briefly or not at all. To prevent this problem from occurring, it is possible to select that the shutdown can only occur via the speed currently active. Depending on the number of fan speeds selected (see Number of fan speeds, Page 268) it is possible that all group objects may not be visible because only the group objects for the speeds actually used are enabled.

The following group objects are displayed if the Switch off to active fan speed using "0" only or Switch off to any 1-bit fan speed using "0" option has been selected:

- Switch fan speed 1
- Switch fan speed 2
- Switch fan speed 3
- Status Fan speed 1
- Status Fan speed 2
- Status Fan speed 3

With the switching object it is possible to control the fan speed (1/2/3) directly. The status objects specify whether the fan speed is currently at the current speed.

- Deactivated: The additional group objects are deactivated and hidden.
- Switch off to active fan speed using "0" only: The additional group objects are enabled. Switching off via these group objects occurs if the Off command ("0") on the switching object is assigned to the currently active speed.
- Switch off to any 1-bit fan speed using "0": The additional group objects are enabled. Switching off via this group object occurs if an Off command ("0") is sent on any of the switching objects.

13.2.305 Fan output - Send status values

| | |
|---------|---|
| Options | On change Cyclically On change and cyclically On request After a change or request On request and cyclically After a change or request and cyclically |
|---------|---|

This parameter defines when the fan output status values are to be sent. This parameter affects the following fan output group objects:

- Status Fan On/Off
- Status Fan Speed
- Status Fan Speed 1
- Status Fan Speed 2
- Status Fan Speed 3
- Status Fan Automatic

If the parameter Switch fan speed via 1-bit objects is parameterized with the

Deactivated option, the group objects Status Fan Speed 1, Status Fan Speed 2 and Status Fan Speed 3 are not displayed.

- On change: The values are sent on a change in the object values (e.g. change from 0 to 1). With the Status Control value group object, the values are sent if the change in the control value is at least 1 %.
- Cyclically: If this option is selected, the status values are sent automatically after an adjustable time has elapsed. The Every dependent parameter is displayed.
- On change and cyclically: The values are sent on a change and cyclically.
- On request: All status values are sent on the receipt of a command via the Request status values group object.
- After a change or request: The values are sent on request and on a change.
- On request and cyclically: The values are sent on a change and cyclically.
- After a change or request and cyclically: The values are sent on request and on a change and cyclically. The Every dependent parameter is displayed.

13.2.306 Fan output - Every

| | |
|---------|----------------------|
| Options | 00:00:30 to 18:12:15 |
|---------|----------------------|

This parameter is used to set the time after which the status values are to be sent cyclically. The group objects are sent after each cycle.



Note: This parameter is available if the send status values "Cyclically, On change and cyclically, On request and cyclically, After a change or request and cyclically" is activated

13.2.307 Electric heater relay output

13.2.308 Electric heater relay output - Electric heater output is

| | |
|---------|--------------------------|
| Options | Deactivated Activated |
|---------|--------------------------|

This parameter activates and deactivates the relay output. When the output is deactivated, the relay can no longer be switched, and the associated group objects Status Relay and Switch Relay are hidden.



Note: When using the relay output as the initial stage for the RTC (for an electric heater), the Switch relay output independently of fan speed (including when fan = 0) parameter prevents the relay from switching on if the fan is not running. This protects the installation in that the fan also routes into the room any heat generated by an electric heater. This prevents heat from building up and becoming a fire risk.

For ON/Off valve version: When Valve B is activated, Electric heater relay Output will be invalid

13.2.309 Electric heater relay output - Electric heater relay output

13.2.310 Electric heater relay output - Electric heater output is

| | |
|---------|--------------------------|
| Options | Deactivated Activated |
|---------|--------------------------|

This parameter activates and deactivates the electric heater relay output. When the output is deactivated, the electric heater relay output can no longer be associated with group objects Status Relay.

When using the electric heater relay output for electric heater, the Switch relay output independently of fan speed (including when fan = 0) parameter prevents the relay from switching on if the fan is not running. This protects the installation in that the fan also routes into the room any heat generated by an electric heater. This prevents heat from building up and becoming a fire risk. Parametrizing one of the device outputs to accept binary signal input makes it possible to link the input with the relay output. This in turn means that the output can be operated directly via a connected switch.

13.2.311 Electric heater relay output - Electric heater output reaction

| | |
|---------|---------------------------------|
| Options | Normally close Normally open |
|---------|---------------------------------|

This parameter determines whether the output operates as a normally closed or normally open contact.

- Normally open: An ON telegram (1) closes the contact, and an OFF telegram (0) opens it.
- Normally closed: An ON telegram (1) opens the contact, and an OFF telegram (0) closes it.

13.2.312 Electric heater relay output - Object value status relay

| | |
|---------|--|
| Options | 1 = closed, 0 = open 0 = closed, 1 = open |
|---------|--|

This parameter determines the group object value of the switching status (Status Relay).

13.2.313 Electric heater relay output - Send status values

| | |
|---------|---|
| Options | On change Cyclically On change and cyclically On request After a change or request On request and cyclically After a change or request and cyclically |
|---------|---|

- On change: Sends the value when the object value changes (e.g. From 0 to 1).
- Cyclically: Selecting this option automatically sends the value after a user-definable time period. Displays the dependent parameter All.
- On change and cyclically: Sends the object value after a change, and cyclically.
- On request: Sends the status value when Request group object Status values receives a command.
- After a change or request: Sends the value both after a change and on request.
- On request and cyclically: Sends the value both on request and cyclically.
- After a change or request and cyclically: Sends the value after a change, on request and cyclically. Displays the dependent parameter All.

13.2.314 Electric heater relay output - Every

| | |
|---------|----------------------|
| Options | 00:00:30 to 18:12:15 |
|---------|----------------------|

This parameter is used to set the time after which the status values are to be sent cyclically. The group objects are sent after each cycle.



Note: This parameter is only visible if the Send group object "Status relay" Cyclically, On change and cyclically, On request and cyclically and After a change or request and cyclically is activated

13.2.315 Setpoint adjustment

13.2.316 Setpoint adjustment - Max. manual increase in heating mode via KNX

| | |
|---------|----------|
| Options | 0 to 9 K |
|---------|----------|

The parameter determines the maximum setpoint increase that can be manually set via KNX in heating mode. You can use the Request setpoint adjustment group object to increase the Comfort heating setpoint by a maximum of the value set here. If the object receives a value that exceeds this, the maximum possible increase is applied, and a request with the new temperature is sent via KNX on the Confirm setpoint adjustment group object.

13.2.317 Setpoint adjustment - Max. manual decrease in heating mode via KNX

| | |
|---------|----------|
| Options | 0 to 9 K |
|---------|----------|

The parameter determines the maximum setpoint reduction that can be manually set via KNX in Heating mode. Use the Request setpoint adjustment group object to reduce the Comfort heating setpoint by a maximum of the value set here. If the object receives a value below this, the maximum possible decrease is applied, and a request with the new temperature is confirmed on the Confirm setpoint adjustment group object.

13.2.318 Setpoint adjustment - Max. manual increase in cooling mode via KNX

| | |
|---------|----------|
| Options | 0 to 9 K |
|---------|----------|

The parameter determines the maximum setpoint increase that can be manually set via KNX in cooling mode. You can use the Request setpoint adjustment group object to increase the Comfort cooling setpoint by a maximum of the value set here. If the object receives a value that exceeds this, the maximum possible increase is applied, and a request with the new temperature is sent via KNX on the Confirm setpoint adjustment group object.

13.2.319 Setpoint adjustment - Max. manual decrease in cooling mode via KNX

| | |
|---------|----------|
| Options | 0 to 9 K |
|---------|----------|

The parameter determines the maximum setpoint reduction that can be manually set via KNX in cooling mode. Use the Request setpoint adjustment group object to reduce the Comfort cooling setpoint by a maximum of the value set here. If the object receives a value below this, the maximum possible decrease is applied, and a request with the new temperature is confirmed on the Confirm setpoint adjustment group object.

13.2.320 Setpoint adjustment - Manual setpoint adjustment via KNX with

| | |
|---------|--|
| Options | DPT 6.010 (meter pulses) DPT 9.001 (absolute temperature value) DPT 9.002 (relative temperature value) |
|---------|--|

This parameter determines the datapoint type used to adjust the setpoint via group objects Request setpoint adjustment and Confirm setpoint adjustment. DPT 9.001 and DPT 9.002 temperature adjustment will not work on legacy ABB devices that do not yet support the latest version of the master/slave concept. For these devices, DPT 6.010 is the only option, which means that other equipment (such as display systems) cannot read the setpoint adjustment. However, they can read or display the current target temperature via the Current setpoint group object. Before adjusting a setpoint with an analog room control unit, please check which setpoint adjustment format the controller supports. You can also communicate setpoint changes for implementation on other equipment via the group objects Base setpoint, Comfort heating setpoint or Comfort cooling setpoint.

Caution! Note that changing the base setpoint also changes the Standby and Economy temperatures. To prevent this, use absolute rather than relative setpoint adjustment (Setpoint manager – Setpoint specification and adjustment). However, note that with both types of adjustment, the parametrized maximum setpoint increase/reduction limits are no longer taken into account.

- DPT 6.010 (meter pulses): This is the only viable option if you are using legacy ABB devices.
- DPT 9.001 (Absolute temperature value): This adjusts the setpoint as an absolute temperature value by sending the new temperature required. Likewise, the Confirm setpoint adjustment group object sends the new temperature as an absolute value.
- DPT 9.002 (relative temperature value): This adjusts the setpoint as a relative temperature value by sending a target temperature change (e.g. +2 °C). Likewise, the Confirm setpoint adjustment group object sends the new temperature as a relative value.

13.2.321 Setpoint adjustment - Manual fan adjustment via KNX with

| | |
|---------|--|
| Options | DPT 5.001 (percentage value) DPT 5.010 (meter pulses) |
|---------|--|

This parameter determines the datapoint type used to adjust the setpoint via group objects Request fan speed adjustment and Confirm fan speed adjustment. DPT 5.001 fan adjustment will not work on legacy ABB devices that do not yet support the latest version of the master/slave concept. For these devices, DPT 5.010 is the only option, which means that other equipment (such as display systems) cannot read the setpoint adjustment. However, they can read or display the current fan speed via the Status Fan speed group object. You also have the option to adjust the fan speed at any time with the Switch fan speed group object.

- DPT 5.001 (percentage value): Selecting this DPT sends the fan adjustment as a 0...100% value. To adjust the fan speed, simply enter the new required value as a percentage.
- DPT 5.010 (meter pulses): This is the only viable option if you are using legacy ABB devices that do not yet support the latest version of the master/slave concept. It is the only way to ensure that the master and slave can communicate. This option sends the fan adjustment as a proprietary value

13.2.322 Setpoint adjustment - Reset manual adjustment via KNX when base setpoint received

| | |
|---------|-----------|
| Options | No Yes |
|---------|-----------|

- Selecting Yes when setting this parameter resets manual setpoint adjustment when a value is received via the Base setpoint group object.
- Selecting No adds the manual setpoint adjustment to the new setpoint when a value is received via the Base setpoint group object.

Example:

Old base setpoint 21 °C + manual adjustment 1.5 °C = 22.5 °C. Group object receives a new base setpoint of 18 °C + previous manual adjustment of 1.5 °C = 19.5 °C.

13.2.323 Setpoint adjustment - Reset manual adjustment via KNX when operating mode changes

| | |
|---------|-----------|
| Options | No Yes |
|---------|-----------|

- No: When the device changes operating modes, the manual adjustment is cleared from active parameters and replaced with the parametrized target temperature for the new mode plus any change sent via the Base setpoint group object.

Example:

Comfort temperature 21 °C + manual adjustment 1.5 °C = 22.5 °C. Change to Eco mode with a parametrized temperature of 17 °C. The device adjusts the temperature to 17 °C because the manual adjustment has been cleared.

- Yes: This option factors in the manual setpoint adjustment on top of the new operating mode temperature.

Example:

Comfort temperature 21 °C + manual adjustment 1.5 °C = 22.5 °C. Change to Eco mode with a parametrized temperature of 17 °C. The device adjusts the temperature to 18.5 °C because the manual adjustment has been factored in.

13.2.324 Setpoint adjustment - Reset manual adjustment via KNX using group object

| | |
|---------|-----------|
| Options | No Yes |
|---------|-----------|

- Selecting Yes, the manual adjustment can be cleared at any time via the Reset manual setpoint adjustment group object.
- Selecting No, hides this group object and you can no longer use it to reset manual setpoint adjustment.

Example:

Resetting manual adjustment of all the devices in a building using a time scheduler in the system

13.2.325 Setpoint adjustment - Slave display indicates

| | |
|---------|----------------------|
| Options | Absolute Relative |
|---------|----------------------|

This parameter determines whether a slave displays a setpoint as absolute or relative.

13.2.326 Input a, Input b

The setting options for inputs a and b are explained below using input a as an example.

The setting options are identical for all inputs.

13.2.327 Input

| | |
|---------|---|
| Input a | Deactivated Window contact Dew point sensor Fill level sensor Temperature sensor Binary signal input |
| Input b | Deactivated Window contact Dew point sensor Fill level sensor Temperature sensor Binary signal input |

This parameter determines what are the signal that will be connected to the input.

13.2.328 Window contact

Selecting Window contact uses the input to connect a floating contact that monitors the open/closed state of the window. Selecting Window contact, Via physical device input on the Application parameters page takes the status of this input into account in room temperature control. Without this setting, the input value is sent on the bus but not taken into account in the device. If several inputs are set to this option and the controller runs an evaluation, all inputs are internally linked by an OR operation. This means that as long as one of the contacts is open, the controller responds as if all of the inputs are open, and only evaluates the window as closed once all contacts signal a closed state. Inputs are scanned after a 230V recovery, download or ETS reset. Their current status is sent on the bus when the sending and switching delay is complete.

13.2.329 Window contact - Window open when

| | |
|---------|--------------------------------|
| Options | Contact open Contact closed |
|---------|--------------------------------|

This parameter determines whether the contact connected to the input is normally open or normally closed.

- Contact open: The window is considered open if the contact is open.
- Contact closed: The window is considered open if the contact is closed.

13.2.330 Window contact - Send status value

| | |
|---------|---------------------------------------|
| Options | On change On change and cyclically |
|---------|---------------------------------------|

- On change: Sends the value only after a change.
- On change and cyclically: Sends the value after a change, and cyclically. Enables the dependent parameter Send input status cyclically.

13.2.331 Window contact - Send input status cyclically

| | |
|---------|----------------------|
| Options | 00:00:30 to 18:12:15 |
|---------|----------------------|



Note: This parameter is available if the send status valve "On change and cyclically" is activated

13.2.332 Dew point sensor

Selecting Dew point sensor uses the input to connect a floating contact that monitors the dew point. Selecting Dew point sensor, Via physical device input on the Application parameters page takes the status of this input into account in room temperature control. Without this setting, the input value is sent on the bus but not taken into account in the controller. If several inputs are set to this option and the controller runs an evaluation, all inputs are internally linked by an OR operation. This means that as long as one of the contacts is open, the controller responds as if all of the inputs are open. Once all contacts signal no dew point alarm, the controller evaluates this as no alarm. Inputs are scanned after a 230V recovery, download or ETS reset. Their current status is sent on the bus when the sending and switching delay is complete.

13.2.333 Dew point sensor - Dew point reached when

| | |
|---------|--------------------------------|
| Options | Contact open Contact closed |
|---------|--------------------------------|

This parameter defines how the input reacts if the dew point is evaluated as reached or not reached. You can also define whether the dew point sensor is a normally closed or normally open contact.

- Contact open: The dew point is considered reached if the contact is open.
- Contact closed: The dew point is considered reached if the contact is closed.

13.2.334 Dew point sensor - Send status value

| | |
|---------|---------------------------------------|
| Options | On change On change and cyclically |
|---------|---------------------------------------|

- On change: Sends the value only after a change.
- On change and cyclically: Sends the value after a change, and cyclically. Enables the dependent parameter Send input status cyclically.

13.2.335 Dew point sensor - Send input status cyclically

| | |
|---------|----------------------|
| Options | 00:00:30 to 18:12:15 |
|---------|----------------------|



Note: This parameter is available if the send status valve "On change and cyclically" is activated.

13.2.336 Fill level sensor

Selecting Fill level sensor uses the input to connect a floating contact that monitors the fill level of a condensation pan. Selecting Fill level sensor, Via physical device input on the Application parameters page takes the status of this input into account in room temperature control. Without this setting, the input value is sent on the bus but not taken into account in the controller. If several inputs are set to this option and the controller runs an evaluation, all inputs are internally linked by an OR operation. This means that as long as one of the contacts is open, the controller responds as if all of the inputs are open. Once all contacts signal no fill level alarm, the controller evaluates this as no alarm. Inputs are scanned after a 230V recovery, download or ETS reset. Their current status is sent on the bus when the sending and switching delay is complete.

13.2.337 Fill level sensor - Fill level reached when

| | |
|---------|--------------------------------|
| Options | Contact open Contact closed |
|---------|--------------------------------|

This parameter defines how the input reacts if the fill level is evaluated as reached or not reached. You can also define whether the fill level sensor is a normally closed or normally open contact.

- Contact open: The fill level is considered reached if the contact is open.
- Contact closed: The fill level is considered reached if the contact is closed.

13.2.338 Fill level sensor - Send status value

| | |
|---------|---------------------------------------|
| Options | On change On change and cyclically |
|---------|---------------------------------------|

- On change: Sends the value only after a change.
- On change and cyclically: Sends the value after a change, and cyclically. Enables the dependent parameter Send input status cyclically.

13.2.339 Fill level sensor - Send input status cyclically

| | |
|---------|----------------------|
| Options | 00:00:30 to 18:12:15 |
|---------|----------------------|



Note: This parameter is available if the send status valve "On change and cyclically" is activated.

13.2.340 Temperature sensor

Selecting Temperature sensor uses the input for temperature readings. It can then log either room temperature or a temperature limitation value. Selecting Temperature input, Via physical device input on the Application parameters page takes the status of this input into account in room temperature control. Without this setting, the input value is sent on the bus but not taken into account in the controller.

In the Basic-stage heating, Additional-stage heating, Basic-stage cooling and Additional-stage cooling parameter windows, selecting Activate temperature limitation, Yes and Input for temperature limitation sensor, Input a means that the temperature sensor value measured here will only be used for temperature limitation and can no longer be used to measure room temperature. The temperature value is output via the 2-byte group object Input x – Temperature. You can also establish whether there is a fault on the input, e.g. a short circuit or cable break. A fault is reported if the resistance falls below 50 ohms or exceeds 100 kohms. Faults are reported via the 1-bit group object Input a – Input fault. If a fault occurs, this object changes state from 0 to 1. These two objects are sent depending on the reaction parametrized in Send status values. If several inputs are set to this option and the controller runs an evaluation, it calculates the average value of all the temperature inputs. Temperature inputs used as temperature limitation sensors are excluded from this calculation. Inputs are scanned after a 230V recovery, download or ETS reset. Their current status is sent on the bus when the sending and switching delay is complete.

13.2.341 Temperature sensor - Temperature sensor type

| | |
|---------|-----|
| Options | NTC |
|---------|-----|

- NTC: Selecting this type of sensor opens the dependent parameter window NTC type so that you can select an NTC subtype.

13.2.342 Temperature sensor - NTC type

| | |
|---------|---|
| Options | NTC10-01 [-15...+100°C] NTC10-02 [-15...+100°C] NTC10-03 [-15...+100°C] NTC20 [0...+100°C] |
|---------|---|

This parameter allows you to choose the NTC sensor type that is connected. An NTC10 sensor has a resistance of 10 kohms at 25 °C. An NTC20 has a resistance of 20 kohms. Individual types vary in terms of their resistance curves.

13.2.343 Temperature sensor - Temperature offset

| | |
|---------|--------------|
| Options | -10 to +10 K |
|---------|--------------|

A maximum offset of ±10 °C can be added to the recorded temperature with this parameter.

13.2.344 Temperature sensor - Cable error compensation

| | |
|---------|---|
| Options | None Via cable length Via cable resistant |
|---------|---|

- Via cable length: Cable error is compensated by entering the cable length.
- Via cable resistance: Cable error is compensated by entering the cable resistance value.

13.2.345 Temperature sensor - Cable length, Single distance

| | |
|---------|------------|
| Options | 1 to 100 m |
|---------|------------|

Sets the one-way cable length of the connected temperature sensor. The maximum cable length permitted between the sensor and device input is 100 m.



Note: This parameter is available if the Cable error compensation "Via cable length" is activated

13.2.346 Temperature sensor - Cross-section of conductor, Value* 0.01 mm²

| | |
|---------|----------|
| Options | 1 to 150 |
|---------|----------|

The cross-section of the conductor to which the temperature sensor is connected is entered using this parameter. The 150 option corresponds to a cross-section of 1.5 mm².



Note: This parameter is available if the Cable error compensation "Via cable length" is activated

13.2.347 Temperature sensor - Cable resistance [total of fwd. ret. conductor (ohms)]

| | |
|---------|------------------|
| Options | 0 to 10000 mohms |
|---------|------------------|

This parameter sets the cable resistance level of the connected temperature sensor. To measure the cable resistance correctly, the conductors must be shorted together at the end of the cable and should not be connected to the analog input.



Note: This parameter is available if the Cable error compensation "Via cable resistance" is activated

13.2.348 Temperature sensor - Filter

| | |
|---------|--|
| Options | Inactive Low (floating mean value over 30 seconds) Medium (floating mean value over 60 seconds) High (floating mean value over 120 seconds) |
|---------|--|

This parameter sets a filter (floating mean value filter). This can be used to set the output value as a mean value using three different options. Using the filter "smooths" the output via the mean value so that it is available for further processing. The filter

therefore has immediate effects on thresholds and calculation values. The higher the degree of filtering, the smoother the result. This means that changes to the output value become slower.

- Inactive: Filter is not active
- Low: floating mean value over 30 seconds
- Medium: floating mean value over 60 seconds
- High: floating mean value over 120 seconds

Example: An erratic change in the sensor signal on Medium will take 30 seconds until the output value is through.

13.2.349 Temperature sensor - Send temperature value

| | |
|---------|--|
| Options | On change Cyclically On change and cyclically On request After a change or on request On request and cyclically After a change or request and cyclically |
|---------|--|

This parameter defines how the output value should be sent. The value is sent on request when Group object General – Request Status values receives a value.

- On change: Sends the output value after a change.
- Cyclically: Sends the output value cyclically.
- On change and cyclically: Sends the output value after a change, and cyclically.
- On request: Sends the output value on request.
- After a change or request: Sends the output value after a change and after a request.
- On request and cyclically: Sends the output value on request, and cyclically.
- After a change or request and cyclically: Sends the output value after a change, on request, and cyclically.

13.2.350 Temperature sensor - Value is sent from a change of

| | |
|---------|-------------|
| Options | 0.2 to 10 K |
|---------|-------------|

This parameter determines the temperature change that triggers sending the output value.



Note: This parameter is available if Send temperature value parameter "After a change, On change and cyclically, After a change or on request, After a change or request and cyclically" is activated

13.2.351 Temperature sensor - Every

| | |
|---------|----------------------|
| Options | 00:00:30 to 18:12:15 |
|---------|----------------------|

The interval for cyclic sending is set with this additional parameter.



Note: This parameter is available if Send temperature value parameter "Cyclically, On change and cyclically, On request and cyclically, After a change or request and cyclically" is activated

13.2.352 Binary signal input

Parameter is applicable to binary signal input a & b

13.2.353 Binary signal input - Distinction between long and short operation

| | |
|---------|-----------|
| Options | No Yes |
|---------|-----------|

This parameter determines whether the input differentiates between short and long operation.

- No: triggering and closing of contact must be more than 1sec.
- Yes: After opening/closing the contact, an initial evaluation determines whether the operation was long or short before triggering any reaction.

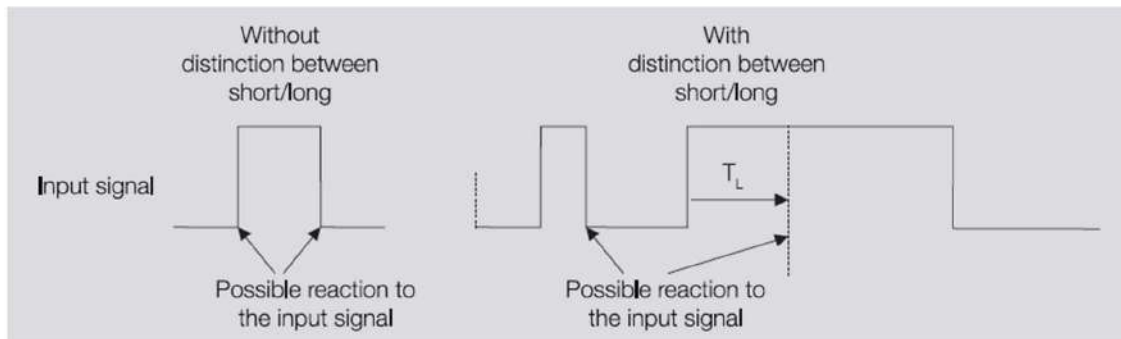

Fig. 56: Distinguishing between a short/long operation

Distinction between long and short operation: If the parameter Distinction between long and short operation is set to No, the following parameters appear:

Opening the contact -> event 0
 Closing the contact -> event 1

13.2.354 Binary signal input - Activate minimum signal duration

| | |
|---------|-----------|
| Options | No Yes |
|---------|-----------|

13.2.355 Binary signal input - When contact opens

| | |
|---------|------------|
| Options | 0 to 100 s |
|---------|------------|



Note: This parameter is available if the Activate minimum signal duration "Yes" is activated

13.2.356 Binary signal input - When closing the contact

| | |
|---------|------------|
| Options | 0 to 100 s |
|---------|------------|



Note: This parameter is available if the Activate minimum signal duration "Yes" is activated

Distinction between long and short operation: If the parameter Distinction between long and short operation is set to Yes, the following parameters appear:

Short operation = event 0
 Long operation = event 1

13.2.357 Binary signal input - Input on operation

| | |
|---------|--------------------------------|
| Options | Contact open Contact closed |
|---------|--------------------------------|

If a normally open contact is connected to the input, select Closed; for a normally closed contact, select Open.

- Contact open: The operation opens the input.
- Contact closed: The operation closes the input

13.2.358 Binary signal input - Long operation after

| | |
|---------|-----------|
| Options | 1 to 10 s |
|---------|-----------|

13.2.359 Binary signal input - 1-bit group object "Disable input a"

| | |
|---------|-----------|
| Options | No Yes |
|---------|-----------|

If the input is disabled and the option Send cyclically is set, the last state is still sent regardless of the block. The Block option blocks the physical input; sending continues internally. When the input is blocked there is essentially no reaction to a signal change on the input, but:

- Waiting for a long button push or a minimum signal duration is suspended
- Parameterized cyclic sending is not interrupted
- It is still possible to write the Switch group object.

If the input state changes during the block phase, the new group object value is sent immediately after the block is released. If the input state remains the same during the block phase, the group object value is not sent. The minimum signal duration does not start until the Block has finished. Block is deactivated after an ETS reset, a 230V recovery or a download.

13.2.360 Binary signal input - Reaction on event 0, Reaction on event 1

| | |
|---------------------|--|
| Reaction on event 0 | No edge evaluation On Off Toggle End cyclic transmission |
| Reaction on event 1 | No edge evaluation On Off |

| | |
|--|-----------------------------------|
| | Toggle End cyclic transmission |
|--|-----------------------------------|

The standard value for Reaction on event 1 is On. The standard value for Reaction on event 0 is Off. This determines how the group object reacts. If the Distinction between long and short operation parameter is set to Yes, the reaction occurs with a short or long operation. If it is set to End cyclic transmission, it is important to note that this is only effective if the Send status value parameter is set to On change and cyclically.

- If it is set to No, it occurs with each edge change

13.2.361 Binary signal input - Internal connection

| | |
|---------|--------------------|
| Options | No Relay output |
|---------|--------------------|

This parameter establishes a direct connection between the binary input and the relay output, dispensing with the need for group address assignment. The Status object on the input is updated along with that on the output. This function allows you to switch the additional relay directly. If the device is being used in controller mode, switching occurs regardless of the function of the controller. If the relay is being used to switch an electric heater, then depending on the application, this can result in the heater being switched on when the fan coil unit is not running, which in turn can lead to the unit overheating.



Note: This parameter is available only to 0~10V version

13.2.362 Binary signal input - Send status value

| | |
|---------|---------------------------------------|
| Options | On change On change and cyclically |
|---------|---------------------------------------|

Cyclic sending enables the Switch group object to send automatically at a fixed interval. If cyclic sending applies to a specific object value only (ON or OFF), this condition refers to the value of the group object. It is therefore possible in principle to start cyclic sending by sending a value to the Switch group object. As this behavior is unwanted, the Write and Update flags of the group object are deleted in the preliminary setting so that they cannot be changed via the bus. If this functionality is required irrespectively, set these flags accordingly. When the group object Switch changes and after 230V recovery (after the sending delay time has elapsed), the group object value is sent immediately on the bus, and the sending cycle time restarts.

- On change: Sends the value only after a change.
- On change and cyclically: Sends the value after a change, and cyclically. Displays the dependent parameters Telegram is repeated every and On object value.

13.2.363 Binary signal input - Telegram is repeated every

| | |
|---------|----------------------|
| Options | 00:00:30 to 18:12:15 |
|---------|----------------------|

This additional parameter sets the interval for cyclic sending.



Note: This parameter is available if the Send status valve "On change and cyclically" is activated.

13.2.364 Binary signal input - On object value

| | |
|---------|------------------|
| Options | 0 1 0 or 1 |
|---------|------------------|

- 1: Sends the group object value 1 cyclically.
- 0: Sends the group object value 0 cyclically.
- 0 or 1: Sends the group object values 0 or 1 cyclically.



Note: This parameter is available if the Send status valve "On change and cyclically" is activated.

13.2.365 Binary signal input - Scan input after download, ETS reset and 230V recovery

| | |
|---------|-----------|
| Options | No Yes |
|---------|-----------|

Scanning starts once the device is ready for normal operation again after the download, ETS reset or 230V recovery. This can take up to 2 seconds.

- No: The object value is not scanned after a download, ETS reset or 230V recovery.
- Yes: The object value is scanned after a download, ETS reset or 230V recovery.

13.2.366 Occupancy presence detection logic

13.2.367 Occupancy presence detection logic - Door open when

| | |
|---------|--------------------------------|
| Options | Contact open Contact closed |
|---------|--------------------------------|

This is to set the object value of door open when door open status is updated via physical device-Input A.



Note: This parameter is available if Occupancy presence detection logic is activated and door contact detection "via physical device-input A" is activated. Input A will be used for Door contact signal.

13.2.368 Occupancy presence detection logic - Send status value

| | |
|---------|---------------------------------------|
| Options | On change On change and cyclically |
|---------|---------------------------------------|

- On change: Sends the value only after a change.
- On change and cyclically: Sends the value after a change, and cyclically. Enables the dependent parameter Send input status cyclically.

13.2.369 Occupancy presence detection logic - Send input status
 cyclically

| | |
|---------|----------------------|
| Options | 00:00:30 to 18:12:15 |
|---------|----------------------|



Note: This parameter is available if the send status valve "On change and cyclically" is activated

13.2.370 Occupancy presence detection logic - Presence detection

| | |
|---------|--------------------------------|
| Options | Contact open Contact closed |
|---------|--------------------------------|

This is to set the object value of presence detection when presence detection status is updated via physical device-Input B.



Note: This parameter is available if Occupancy presence detection logic is activated and door contact detection "via physical device-input B" is activated. Input B will be used for presence detection signal.

13.2.371 Occupancy presence detection logic - Send status value

| | |
|---------|--|
| Options | After a change On change and cyclically |
|---------|--|

- On change: Sends the value only after a change.
- On change and cyclically: Sends the value after a change, and cyclically. Enables the dependent parameter Send input status cyclically.

13.2.372 Occupancy presence detection logic - Send input status
 cyclically

| | |
|---------|----------------------|
| Options | 00:00:30 to 18:12:15 |
|---------|----------------------|



Note: This parameter is available if the send status valve "On change and cyclically" is activated

13.2.373 Internal Temperature sensor

13.2.374 Internal temperature sensor - Input

| | |
|---------|--------------------|
| Options | Temperature sensor |
|---------|--------------------|

This parameter is for the adjustment of inbuilt internal temperature sensor.

13.2.375 Internal temperature sensor - Temperature sensor type

| | |
|---------|-----|
| Options | NTC |
|---------|-----|

13.2.376 Internal temperature sensor - NTC type

| | |
|---------|-------------------------|
| Options | NTC10-01 [-15...+100°C] |
|---------|-------------------------|

13.2.377 Internal temperature sensor - Temperature offset

| | |
|---------|--------------|
| Options | -10 to +10 K |
|---------|--------------|

A maximum offset of ± 10 °C can be added to the recorded temperature with this parameter.

13.2.378 Internal temperature sensor - Filter

| | |
|---------|--|
| Options | Inactive Low (floating mean value over 30 seconds) Medium (floating mean value over 60 seconds) High (floating mean value over 120 seconds) |
|---------|--|

This parameter sets a filter (floating mean value filter). This can be used to set the output value as a mean value using three different options. Using the filter "smooths" the output via the mean value so that it is available for further processing. The filter therefore has immediate effects on thresholds and calculation values. The higher the degree of filtering, the smoother the result. This means that changes to the output value become slower.

- Inactive: Filter is not active
- Low: floating mean value over 30 seconds
- Medium: floating mean value over 60 seconds
- High: floating mean value over 120 seconds

Example: An erratic change in the sensor signal on Medium will take 30 seconds until the output value is through.

13.2.379 Internal temperature sensor - Send temperature value

| | |
|---------|--|
| Options | On change Cyclically On change and cyclically On request After a change or on request On request and cyclically After a change or request and cyclically |
|---------|--|

This parameter defines how the output value should be sent. The value is sent on request when Group object General – Request Status values receives a value.

- On change: Sends the output value after a change.
- Cyclically: Sends the output value cyclically.
- On change and cyclically: Sends the output value after a change, and cyclically.
- On request: Sends the output value on request.
- After a change or request: Sends the output value after a change and after a request.
- On request and cyclically: Sends the output value on request, and cyclically.
- After a change or request and cyclically: Sends the output value after a change, on request, and cyclically.

13.2.380 Internal temperature sensor - Value is sent from a change of

| | |
|---------|-------------|
| Options | 0.2 to 10 K |
|---------|-------------|

This parameter determines the temperature change that triggers sending the output value.



Note: This parameter is available if Send temperature value parameter "After a change, On change and cyclically, After a change or on request, After a change or request and cyclically" is activated

13.2.381 Internal temperature sensor - Every

| | |
|---------|----------------------|
| Options | 00:00:30 to 18:12:15 |
|---------|----------------------|

The interval for cyclic sending is set with this additional parameter.



Note: This parameter is available if Send temperature value parameter "Cyclically, On change and cyclically, On request and cyclically, After a change or request and cyclically" is activated

13.3 Group Objects

Summary of Caldion group objects

| No | Function | Name | Length | Data Point Type | Flags |
|---|-----------------------|---------|--------|-----------------|---------|
| 1 | In operation | General | 1 bit | DPT 1.002 | C, R, T |
| <p>The group object is enabled if the parameter Enable group object "In operation" 1 bit is set to Yes in the General parameter window. In order to regularly monitor the presence of the device on the KNX, a telegram In operation is sent cyclically on the bus. As long as the group object is activated, it sends a parameterizable In operation telegram. The telegram value depends on the option selected in Parameter Send.</p> | | | | | |
| 2 | Status byte device | General | 1 byte | Non DPT | C, R, T |
| <p>This group object is always enabled and indicates the current device state. It indicates whether the device is working normally or whether manual override is in effect. This group object maps the following information:</p> <ul style="list-style-type: none"> • Bit 0: Operating mode overridden The RTC was overridden via the group object Operating mode override. – 0: No override – 1: Override active • Bit 1: Building Protection The device is in Building Protection mode due to dew point/fill level alarm or an open window – 0: Building protection – 1: Building protection active • Bit 2: Forced operation Forced operation was activated. – 0: Forced operation inactive – 1: Forced operation active • Bit 5: Security Mode The device is in Security Mode, e.g. due to temperature value or control value failure; a defined control value applies. The device is operating normally when the group object value is 0 (= all individual bits = 0). | | | | | |
| 3 | On/Off reaction | General | 1 bit | DPT 1.002 | C, W |
| <p>This group object enabled RTC define the On/off reaction via group object 1 = default / 0 = recovery 1 = recovery / 0 = default On/Off reaction set to "default", every time when the device is turn on after it is off, device setpoint and fan speed will be in default value. On/Off reaction set to "recovery", every time when the device is turn on after it is off, device setpoint and fan speed will be set to the setting values before it is turn off.</p> | | | | | |
| 4 | Request status values | General | 1 bit | DPT 1.017 | C, W |
| <p>This group object is always enabled. When this group object receives a telegram with the value 0 or 1, all group objects Status are sent on the bus if they were parametrized with On request.</p> | | | | | |
| 5 | Switchover units | General | 1 bit | DPT 1.002 | C, W |
| <p>This group object enabled to switch inbetween °C/°F via group object 1 = °C, 0 = °F 1 = °F, 0 = °C To switchover between °C and °F using 1-bit communication object</p> | | | | | |

KNX Technical Reference Manual
ABB i-Bus® KNX Caldion®

| | | | | | |
|---|------------------------------|-------------|--------|-----------|---------|
| 6 | Lock/unlock device | General | 1 bit | DPT 1.002 | C, W |
| <p>This group object enabled RTC to be lock or unlock via group object. 1 =lock / 0 =unlock 1 = unlock / 0 = lock To parameter lock / unlock of device via group object. Device to be lock / unlock by group object set to activate, device function would be control via the 1-bit communication object "Device function". When device is lock, device will operate as per last setting function before it is lock and local button function will be inactive. When device is unlocked, normal operation will be in place.</p> | | | | | |
| 7 | Display illumination | General | 1 bit | DPT 1.002 | C, W |
| <p>This group object enabled RTC display illumination to be control via group object 1 = Illumination efficient / 0 = Constantly on 1 = Constantly on / 0 = Illumination efficient</p> <p>If "Display illumination activate / deactivate by group object" parameter is activated, display illumination would be control via the 1-bit communication object "Display illumination".</p> <p>Scenario: If Display illumination is set to "Illumination efficient" and Display illumination activate / deactivate by group object is "1 = Illumination efficient / 0 = Constantly on". Sending of Display illumination group object = 1, display illumination will be turn off after a set duration of time from last trigger command as device enter into illumination efficient mode. Sending of Display illumination group object = 0, Display illumination will remain active and permanently on. During illumination efficient mode, any touch on the device for change of setting will turn on the display illumination for time duration set in "Time for display illumination to turn off after last trigger", after the time is lapse, the display illumination will turn off and wait for next touch on the device.</p> | | | | | |
| 8 | Button icon LED illumination | General | 1 bit | DPT 1.002 | C, W |
| <p>This group object enabled RTC button LED illumination to be control via group object 1 = Illumination efficient / 0 = Constantly on 1 = Constantly on / 0 = Illumination efficient</p> <p>Scenario: If Button icon LED illumination is set to "Illumination efficient" and Button icon LED illumination activate / deactivate by group object is "1 = Illumination efficient / 0 = Constantly on". Sending of Button icon LED illumination group object = 1, button icon LED illumination will be turn off immediately after receiving group object = 1, or after a setting duration of time from last trigger command, it will off the LED illumination and enter into illumination efficient mode. Sending of Button icon LED illumination group object = 0, Button icon LED illumination will remain active and permanently on. During illumination efficient mode, any touch on the device for change of setting will turn on the Button icon LED illumination for time duration set in "Time for Button icon LED illumination to turn off after last trigger", after the time is lapse, the Button icon LED illumination will turn off and await for next touch on the device</p> | | | | | |
| 10 | Fan On/Off status | Channel-Fan | 1 bit | DPT 1.001 | C, R, T |
| <p>This group object is always enabled. The group object value is 1 when the fan control value (speed) is unequal to 0.</p> | | | | | |
| 11 | Status byte fan | Channel-Fan | 1 byte | Non DPT | C, R, T |
| <p>This group object is always enabled. This group object indicates the current fan status.</p> <ul style="list-style-type: none"> • Bit 0: Fan on <p>This bit indicates whether the fan is on or off.</p> <ul style="list-style-type: none"> – 0: Fan off – 1: Fan on <ul style="list-style-type: none"> • Bit 1: Output error <p>The bit indicates whether there is an error at the fan output. This may be a short circuit or overload. This can be determined only for analog fan outputs. This group object is always 0 for devices with relay fan output.</p> <ul style="list-style-type: none"> – 0: No error – 1: Error at output <ul style="list-style-type: none"> • Bit 2: Forced operation <p>Indicates whether forced operation is active or not.</p> <ul style="list-style-type: none"> – 0: Forced operation inactive – 1: Forced operation active <ul style="list-style-type: none"> • Bit 3: Limitation 1 <p>Limitation 1 is active, and this may limit the fan speed.</p> <ul style="list-style-type: none"> – 0: Limitation 1 inactive – 1: Limitation 1 active <ul style="list-style-type: none"> • Bit 4: Limitation 2 <p>Limitation 2 is active, and this may limit the fan speed.</p> <ul style="list-style-type: none"> – 0: Limitation 2 inactive – 1: Limitation 2 active <ul style="list-style-type: none"> • Bit 5: Limitation 3 <p>Limitation 3 is active, and this may limit the fan speed.</p> <ul style="list-style-type: none"> – 0: Limitation 3 inactive – 1: Limitation 3 active <ul style="list-style-type: none"> • Bit 6: Automatic <p>The group object indicates whether or not the fan is in automatic mode.</p> <ul style="list-style-type: none"> – 0: Automatic mode inactive – 1: Automatic mode active | | | | | |
| 12 | Status Fan automatic | Channel-Fan | 1 bit | DPT 1.011 | C, R, T |

KNX Technical Reference Manual

ABB i-Bus® KNX Caldion®

| | | | | | |
|---|------------------------------------|-------------|--------|-----------|---------|
| <p>This group object is enabled if Automatic operation has been enabled in the Fan output parameter window. This group object is always enabled in controller mode. The group object indicates the status of automatic operation. Telegram value: • 0 = Inactive • 1 = Active</p> | | | | | |
| 13 | Status Fan speed | Channel-Fan | 1 byte | DPT 5.001 | C, R, T |
| <p>This group object is always enabled. This group object indicates the current fan speed. The following status values are output for a 3-speed fan: • Speed 0: 0 (0 %) • Speed 1: 85 (33 %) • Speed 2: 170 (66 %) • Speed 3: 255 (100 %) The following status values are output for a 2-speed fan: • Speed 0: 0 (0 %) • Speed 1: 128 (50 %) • Speed 2: 255 (100 %) The following status values are output for a 1-speed fan: • Speed 0: 0 (0 %) • Speed 1: 255 (100 %)</p> | | | | | |
| 14 | Status Fan speed 1 | Channel-Fan | 1 bit | DPT 1.001 | C, R, T |
| <p>This group object is enabled if the parameter Switch fan speed via 1-bit objects is set to Switch off to active fan speed using "0" only or Switch off to any 1 bit fan speed using "0" in the Fan speed parameter window. This indicates whether the fan is at speed 1. Telegram value: • 0: Fan speed Off • 1: Fan speed On</p> | | | | | |
| 15 | Status Fan speed 2 | Channel-Fan | 1 bit | DPT 1.001 | C, R, T |
| <p>See group object 14 This group object is hidden if only a 1-speed fan was selected.</p> | | | | | |
| 16 | Status Fan speed 3 | Channel-Fan | 1 bit | DPT 1.001 | C, R, T |
| <p>See group object 14 This group object is hidden if only a 1- or 2-speed fan was selected.</p> | | | | | |
| 17 | Activate/deactivate fan automation | Channel-Fan | 1 bit | DPT 1.003 | C, W |
| <p>This group object is enabled if the parameter Enable automatic mode based on control value is set to Yes in the Fan output parameter window. This group object is always enabled. Sending the value 1 on this group objects activates automatic mode. Automatic mode can also be activated/deactivated via the group object Request fan manually. This group object is used for slave communication there. After 230V recovery, ETS reset and download, automatic mode can be directly reactivated by selecting the corresponding parameters (see)</p> | | | | | |
| 18 | Switch speed 1 | Channel-Fan | 1 bit | DPT 1.001 | C, W |
| <p>This group object is enabled if the parameter Switch fan speed via 1-bit objects is set to Switch off to active fan speed using "0" only or Switch off to any 1 bit fan speed using "0" in the Fan speed parameter window. The fan changes to the corresponding speed when a 1 is sent on this group object. The reaction on sending a 0 depends on the selection of the parameter Switch fan speed via 1 bit group objects: • When Switch off to active fan speed using "0" only is selected, a 0 switches off the fan only if the fan is running at this fan speed. If not, reception has no effect. • When the option Switch off to any 1 bit fan speed using "0" is selected, receiving a 0 always switches the fan off.</p> | | | | | |
| 19 | Switch speed 2 | Channel-Fan | 1 bit | DPT 1.001 | C, W |
| <p>See group object 18 This group object is hidden if only a 1-speed fan was selected.</p> | | | | | |
| 20 | Switch speed 3 | Channel-Fan | 1 bit | DPT 1.001 | C, W |
| <p>See group object 18 This group object is hidden if only a 1- or 2-speed fan was selected.</p> | | | | | |
| 21 | Switch fan speed | Channel-Fan | 1 byte | DPT 5.001 | C, W |
| <p>This group object is always enabled. This group object sets the fan speed directly. The speeds are controlled via the following values for a 3-speed fan: • Speed 0: 0 (0 %) • Speed 1: 1...85 (1...33 %) • Speed 2: 85...170 (34...66 %)</p> | | | | | |

KNX Technical Reference Manual

ABB i-Bus® KNX Caldion®

- Speed 3: 171...255 (67...100 %)
- The speeds are controlled via the following values for a 2-speed fan:
- Speed 0: 0 (0 %)
 - Speed 1: 1...128 (1...50 %)
 - Speed 2: 129...255 (51...100 %)
- The speeds are controlled via the following values for a 1-speed fan:
- Speed 0: 0 (0 %)
 - Speed 1: 1...255 (1...100 %)

| | | | | | |
|---|-----------------------------|-----------------|--------|-----------|---------|
| 22 | Increase/decrease fan speed | Channel-Fan | 1 bit | DPT 1.007 | C, W |
| <p>This group object is always enabled. With this group object, the fan can be switched one fan speed further up or down via a 1 bit telegram. This can be done until the maximum or minimum fan speed is reached. The parameterized limitations are taken into account here. Further UP or DOWN telegrams are ignored and not executed. Telegram value:</p> <ul style="list-style-type: none"> • 0 = Switch fan speed DOWN • 1 = Switch fan speed UP | | | | | |
| 23 | Limitation 1 | Channel-Fan | 1 bit | DPT 1.003 | C, W |
| <p>This group object is enabled if the parameter Fan speed limitation is set to Activated in the Fan output parameter window. Limitation 1 is active when a telegram with the value 1 is received on the group object Limitation 1. Limitation 1 is canceled when a telegram with the value 0 is received on the group object Limitation 1. When Limitation 1 is activated, the fan can assume the only the fan speed or speed range as set in the parameter Limitation 1. Telegram value:</p> <ul style="list-style-type: none"> • 0 = Limitation x inactive • 1 = Limitation x active | | | | | |
| 24 | Limitation 2 | Channel-Fan | 1 bit | DPT 1.003 | C, W |
| See group object 23 | | | | | |
| 25 | Limitation 3 | Channel-Fan | 1 bit | DPT 1.003 | C, W |
| See group object 23 | | | | | |
| 26 | Status byte Valve A | Channel-Valve A | 1 byte | Non DPT | C, R, T |
| <p>This group object is enabled as along as the valve output has not been parametrized with Deactivated. This group object indicates the current valve status.</p> <ul style="list-style-type: none"> • Bit 0: Setpoint received/control value received <p>This bit indicates whether or not the valve received a valid control value.</p> <ul style="list-style-type: none"> – 0: Setpoint/control value received – 1: Setpoint/control value not received <p>Note</p> <p>This bit retains the value 0 during the entire run time if cyclical monitoring is not used (for the operating mode in controller mode or for the control value in actuator mode), because no cycle time was defined during which a new value must be received.</p> <ul style="list-style-type: none"> • Bit 1: Output error <p>The bit indicates whether there is an error at the valve output. This may be a short circuit or overload.</p> <ul style="list-style-type: none"> – 0: No error – 1: Error at output <ul style="list-style-type: none"> • Bit 2: Forced operation <p>Indicates whether forced operation is active or not.</p> <ul style="list-style-type: none"> – 0: Forced operation inactive – 1: Forced operation active <ul style="list-style-type: none"> • Bit 3: Valve purge <p>The bit indicates whether or not valve purge is active.</p> <ul style="list-style-type: none"> – 0: Valve purge inactive – 1: Valve purge active | | | | | |
| 27 | Status Control value A | Channel-Valve A | 1 byte | DPT 5.001 | C, R, T |
| <p>This group object is enabled as along as the valve output has not been parametrized with deactivated. The group object indicates the active valve control value from 0...100 %.</p> | | | | | |
| 28 | Fault: valve output A | Channel-Valve A | 1 bit | DPT 1.002 | C, R, T |
| <p>This group object is enabled as along as the valve output has not been parametrized with Deactivated. If there is a fault on the output, e.g. due to short circuit or overloading, the valve selector's LED and, if a channel is selected, the "Open" LED flash. The group object simultaneously sends a telegram with the value 1. The output is switched off in the event of a fault. The group object value is 0 after the fault has been remedied.</p> | | | | | |
| 29 | Status Valve purge A | Channel-Valve A | 1 bit | DPT 1.011 | C, R, T |
| <p>This group object is enabled via the parameter Valve purge in the Valve output A parameter window unless Deactivated is set. The status of the valve purge is displayed via this group object.</p> | | | | | |

KNX Technical Reference Manual

ABB i-Bus® KNX Caldion®

| | | | | | |
|--|--|-----------------|--------|-----------|---------|
| <p>The status is sent depending on the option selected in the parameter Send group object "Status Valve purge".</p> <p>Telegram value:</p> <ul style="list-style-type: none"> • 0 = Valve purge inactive • 1 = Valve purge active | | | | | |
| 30 | Reset fault on valve output A | Channel-Valve A | 1 bit | DPT 1.015 | C, W |
| <p>If there is an active fault on the valve output, a reset can be performed with the telegram value 1 via this group object. A reset is only successful if the fault has been repaired and is no longer present. The fault can also be reset by restarting or by an ETS reset. The device can be restarted by disconnecting and reconnecting the 230V power supply.</p> | | | | | |
| 31 | Activate valve purge A | Channel-Valve A | 1 bit | DPT 1.017 | C, W |
| <p>This group object is enabled via the parameter Valve purge in the Valve output A parameter window unless Deactivated is set. This group object can initiate a valve purge. A valve purge not undertaken due to a higher priority will no longer be undertaken.</p> | | | | | |
| 32 | Enable/disable manual override valve A | Channel-Valve A | 1 bit | DPT 1.003 | C, W |
| <p>This group object is enabled by selecting Yes in the parameter Enable manual valve override. If manual valve override is enabled, the value in group object Override valve control value is written directly to the valve output. The value specified by the RTC, or specified via a group object Control value in actuator mode, is overridden.</p> <p>Telegram value:</p> <ul style="list-style-type: none"> • 0: Manual override disabled • 1: Manual override enabled <p>When a 0 is received on this group object, manual override is immediately blocked and the value specified by the RTC, or specified via group object Control value in actuator mode, applies again.</p> | | | | | |
| 33 | Override valve control value A | Channel-Valve A | 1 byte | DPT 5.001 | C, W |
| <p>This group object is enabled by selecting Yes in the parameter Enable manual valve override. This group object can send a manual valve control value for overriding the valve, e.g. for test purposes. The value on this group object becomes active only when overriding has been enabled by the group object Enable/disable manual override valve. A block via this group object immediately cancels the overridden value.</p> | | | | | |
| 34 | Control value VAV damper control A | Channel-Valve A | 1 byte | DPT 5.001 | C, W |
| <p>This group object is enabled if the parameter Valve output is set to Use as VAV damper output in the Valve output A parameter window. This group object receives the control valve to be issued via the output. The control value received via the group object is converted to an output voltage in the parametrized range and output. Group object is only available in 0~10V version</p> | | | | | |
| 35 | Status byte Valve B | Channel-Valve B | 1 byte | Non DPT | C, R, T |
| See group object 26 | | | | | |
| 36 | Status control valve B | Channel-Valve B | 1 byte | DPT 5.001 | C, R, T |
| See group object 27 | | | | | |
| 37 | Fault: valve output B | Channel-Valve B | 1 bit | DPT 1.002 | C, R, T |
| See group object 28 | | | | | |
| 38 | Status Valve purge B | Channel-Valve B | 1 bit | DPT 1.011 | C, R, T |
| See group object 29 | | | | | |
| 39 | Reset fault on valve output B | Channel-Valve B | 1 bit | DPT 1.015 | C, W |
| See group object 30 | | | | | |
| 40 | Activate valve purge B | Channel-Valve B | 1 bit | DPT 1.017 | C, W |
| See group object 31 | | | | | |
| 41 | Enable/disable manual override valve B | Channel-Valve B | 1 bit | DPT 1.003 | C, W |
| See group object 32 | | | | | |
| 42 | Override valve control value B | Channel-Valve B | 1 byte | DPT 5.001 | C, W |
| See group object 33 | | | | | |
| 43 | Control value VAV damper control B | Channel-Valve B | 1 byte | DPT 5.001 | C, W |
| See group object 34 | | | | | |
| 44 | Status relay | Channel-Relay | 1 bit | DPT 1.009 | C, R, T |
| <p>This group object is enabled if the parameter Output is is set to Activated in the Relay output parameter window. The group object indicates the status of the relay depending on the option selected in the parameter Object value Status Relay:</p> <p>Telegram value:</p> <ul style="list-style-type: none"> • 1 = relay closed; 0 = relay open • 0 = relay closed; 1= relay open <p>The status is sent depending on the option selected in the parameter Send status values (Electric heater relay output parameter window).</p> | | | | | |

KNX Technical Reference Manual
ABB i-Bus® KNX Cالدion®

| | | | | | |
|--|----------------------------------|-----------------|--------|-----------|---------|
| 45 | Switch relay | Channel-Relay | 1 bit | DPT 1.001 | C, W |
| <p>This group object is enabled if the parameter Output is set to Activated in the Electric heater relay output parameter window. This group object switches the relay output. Telegram value: • 1: On • 0: Off Whether the relay opens or closes depends on the parametrization as a normally closed or normally open contact. Note If the relay output is used as the RTC output drive (for an electric heater), the parameter Switch relay output independently of fan speed (including when fan = 0) can be used to prevent the relay from switching on when the fan is not running. This serves to protect the installation by ensuring that the fan always transports the heat produced by an electric heater into the room. This prevents heat build-up and the resulting fire risk.</p> | | | | | |
| 46 | Forced operation 2-bit | Channel-General | 2 bit | DPT 2.001 | C, W |
| <p>This group object is enabled if the parameter Use forced operation is set to Forced operation 2 bit in the Monitoring and safety parameter window. This group object activates and deactivates forced operation. Telegram value (bit 1 bit 0: Status Forced operation): • 0 0: Forced operation inactive • 0 1: Forced operation inactive • 1 0: Forced operation active; state OFF • 1 1: Forced operation active; state ON</p> | | | | | |
| 47 | Forced operation 1-bit | Channel-General | 1 bit | DPT 1.002 | C, W |
| <p>The group object is enabled if the parameter Use forced operation is set to Forced operation 1 bit, 0 active or Forced operation 1 bit, 1 active in the Monitoring and safety parameter window. This group object activates and deactivates forced operation. Depending on the selected option, forced operation is activated with a 1 or 0 and deactivated with a 0 or 1.</p> | | | | | |
| 48 | Error: heating/cooling receipt | Channel-General | 1 bit | DPT 1.002 | C, R, T |
| <p>This group object is enabled if the parameter Monitor receipt of group object "Toggle heating/cooling" is set to Activated in the Monitoring and safety parameter window. This group object changes to the value 1 if the parametrized monitoring time was exceeded without a value being received on the group object. The status changes back to 0 when the group object is received again. The group object is sent on each state change (0 > 1 or 1 > 0).</p> | | | | | |
| 49 | Error: window status receipt | Channel-General | 1 bit | DPT 1.002 | C, R, T |
| <p>This group object is enabled if the parameter Monitor receipt of group object "Window contact" is set to Activated in the Monitoring and safety parameter window. This group object changes to the value 1 if the parametrized monitoring time was exceeded without the group object being received. The status changes back to 0 when the group object is received again. The group object is sent on each state change (0 > 1 or 1 > 0).</p> | | | | | |
| 50 | Error: dew point status receipt | Channel-General | 1 bit | DPT 1.002 | C, R, T |
| <p>This group object is enabled if the parameter Monitor receipt of group object "Dew point alarm" is set to Activated in the Monitoring and safety parameter window. This group object changes to the value 1 if the parametrized monitoring time was exceeded without the group object being received. The status changes back to 0 when the group object is received again. The group object is sent on each state change (0 > 1 or 1 > 0)</p> | | | | | |
| 51 | Error: fill level status receipt | Channel-General | 1 bit | DPT 1.002 | C, R, T |
| <p>This group object is enabled if the parameter Monitor receipt of group object "Fill level alarm" is set to Activated in the Monitoring and safety window. This group object changes to the value 1 if the parametrized monitoring time was exceeded without the group object being received. The status changes back to 0 when the group object is received again. The group object is sent on each state change (0 > 1 or 1 > 0).</p> | | | | | |
| 52 | Error: operation mode receipt | Channel-General | 1 bit | DPT 1.002 | C, R, T |
| <p>This group object is enabled if the parameter Monitor receipt of group object "Operating mode" is set to Activated in the Monitoring and safety parameter window. This group object changes to the value 1 if the parametrized monitoring time was exceeded without the group object being received. The status changes back to 0 when the group object is received again. The group object is sent on each state change (0 > 1 or 1 > 0).</p> | | | | | |
| 53 | Temperature | Channel-Input a | 2 byte | DPT 9.001 | C, R, T |
| <p>This group object is enabled if the parameter Input is set to Temperature sensor in the Input a parameter window. This group object sends the temperature value measured at the input on the bus depending on the reaction parametrized in the parameter Send temperature value.</p> | | | | | |
| 54 | Input error | Channel-Input a | 1 bit | DPT 1.002 | C, R, T |
| <p>This group object is enabled if the parameter Input is set to Temperature sensor in the Input a parameter window. This group object is also enabled if the parameter Connect analog room control unit to physical device input a is set to Yes in the Setpoint adjustment parameter window.</p> | | | | | |

KNX Technical Reference Manual

ABB i-Bus® KNX Cالدion®

| | | | | | |
|---|-------------------------------------|----------------------|--------|-----------|---------|
| This group object changes its status to 1 if a fault (idling or short circuit) is found at the input and it is therefore no longer possible to send measured values. If there is not fault at the input, this group object value is 0. | | | | | |
| 55 | Switch | Channel-Input a | 1 bit | DPT 1.001 | C, R, T |
| This group object is enabled if the parameter Input is set to Binary signal input in the Input a parameter window. Depending on the selected parametrization, this group object indicates the contact position of the binary sensor connected to the input. | | | | | |
| 55 | Window contact | Channel-Input a | 1 bit | DPT 1.019 | C, R, T |
| This group object is enabled if the parameter Input is set to Window contact in the Input a parameter window. Depending on the selected parametrization, this group object indicates the state of the window contact connected to the input. | | | | | |
| 55 | Dew point alarm | Channel-Input a | 1 bit | DPT 1.005 | C, R, T |
| This group object is enabled if the parameter Input is set to Dew point sensor in the Input a parameter window. Depending on the selected parametrization, this group object indicates the state of the dew point sensor connected to the input. | | | | | |
| 55 | Fill level alarm | Channel-Input a | 1 bit | DPT 1.005 | C, R, T |
| This group object is enabled if the parameter Input is set to Fill level sensor in the Input a parameter window. Depending on the selected parametrization, this group object indicates the state of the fill level sensor connected to the input. | | | | | |
| 55 | Occupancy door status | Channel-Input a | 1 bit | DPT 1.019 | C, R, T |
| This group object is enabled if the parameter Occupancy presence detection logic and door contact detection via physical device-input A is activated Depending on the selected parametrization, this group object indicates the state of the door open when status when it is connected to the input. | | | | | |
| 56 | Disable input | Channel-Input a | 1 bit | DPT 1.003 | C, W |
| This group object is enabled if the parameter Input is set to Binary signal input in the Input a parameter window. The physical input is enabled or disabled via the group object Disable input. Note When the input is blocked there is fundamentally no reaction to a signal change on the input, but: <ul style="list-style-type: none"> • Waiting for a long button operation or a minimum signal duration is suspended. • Parameterized cyclic transmission is not interrupted. • The group object Switch can still be written. If the input state changed during the blocking phase, this leads to immediate sending of the new group object value after enabling. If the input state remains the same during the blocking phase, the group object value is not sent. Telegram value: <ul style="list-style-type: none"> • 0 = Enable input a • 1 = Block input a | | | | | |
| 57 | Temperature | Channel-Input b | 2 byte | DPT 9.001 | C, R, T |
| Input b | | | | | |
| 58 | Input error | Channel-Input b | 1 bit | DPT 1.002 | C, R, T |
| Input b | | | | | |
| 59 | Switch | Channel-Input b | 1 bit | DPT 1.001 | C, R, T |
| Input b | | | | | |
| 59 | Window contact | Channel-Input b | 1 bit | DPT 1.019 | C, R, T |
| Input b | | | | | |
| 59 | Dew point alarm | Channel-Input b | 1 bit | DPT 1.005 | C, R, T |
| Input b | | | | | |
| 59 | Fill level alarm | Channel-Input b | 1 bit | DPT 1.005 | C, R, T |
| Input b | | | | | |
| 59 | Occupancy presence detection status | Channel-Input b | 1 bit | DPT 1.001 | C, R, T |
| This group object is enabled if the parameter Occupancy presence detection logic and presence detection via physical device-input B is activated Depending on the selected parametrization, this group object indicates the state of the presence detect when status when it is connected to the input. | | | | | |
| 60 | Disable input | Channel-Input b | 1 bit | DPT 1.003 | C, W |
| Input c | | | | | |
| 61 | Temperature | Channel-Input c | 2 byte | DPT 9.001 | C, R, T |
| Input c | | | | | |
| 62 | Input error | Channel-Input c | 1 bit | DPT 1.002 | C, R, T |
| Input c | | | | | |
| 69 | Status Heating/Cooling | Channel – Controller | 1 bit | DPT 1.100 | C, R, T |
| This group object is enabled if the controller was parametrized for both heating and cooling. For this purpose, Deactivated must not be selected for the parameters Basic-stage heating and Basic-stage cooling in the Application parameters parameter window. | | | | | |

KNX Technical Reference Manual

ABB i-Bus® KNX Cالدion®

The group object indicates whether the system is currently heating or cooling. Heating/cooling switchover takes place for controlled devices depending on this group object.

Telegram value:

- 0: Cooling
- 1: Heating

| | | | | | |
|----|--|----------------------|--------|-----------|---------|
| 70 | Status Control Value Basic stage heating | Channel – Controller | 1 byte | DPT 5.001 | C, R, T |
|----|--|----------------------|--------|-----------|---------|

The group object is enabled if Deactivated was not selected for the parameter Basic-stage heating in the Application parameters parameter window.

The group object data point type depends on the selected application and the associated control.

Output is via a 1-byte value (DPT 5.001) when the following control types are selected:

- 2-point 1 byte (0/100 %)
- PI continuous (0...100 %)
- PI continuous (0...100 %) for Fan Coil

Output is via a 1-bit value (DPT 1.001) when the following control types are selected:

- 2-point 1 bit (On/Off)
- PI PWM (On/Off)

This group object outputs the control value for Basic-stage heating.

Use of a physical device output (e.g. valve) for basic-stage heating.

- The group object contains the control value that the controller uses to control the output.

Basic-stage heating is controlled only via group object (no internal use):

- The group object sends the control value for controlling a different actuator.

| | | | | | |
|----|--|----------------------|-------|-----------|---------|
| 70 | Status Control Value Basic stage heating | Channel – Controller | 1 bit | DPT 1.001 | C, R, T |
|----|--|----------------------|-------|-----------|---------|

See above

| | | | | | |
|----|---|----------------------|--------|-----------|---------|
| 71 | Status Control Value Additional-stage heating | Channel – Controller | 1 byte | DPT 5.001 | C, R, T |
|----|---|----------------------|--------|-----------|---------|

The group object is enabled if Deactivated was not selected for the parameter Additional-stage heating in the Application parameters parameter window.

The group object data point type depends on the selected application and the associated control.

Output is via a 1-byte value (DPT 5.001) when the following control types are selected:

- 2-point 1 byte (0/100 %)
- PI continuous (0...100 %)
- PI continuous (0...100 %) for Fan Coil

Output is via a 1-bit value (DPT 1.001) when the control types are selected:

- 2-point 1 bit (On/Off)
- PI PWM (On/Off)

The control type is preselected by the parameter Parameter Additional-stage heating in this case. A certain type of control is preset depending on the selected application. The control type is freely selectable if Free configuration is selected in this parameter.

This group object outputs the control value for Additional-stage heating.

Use of a physical device output (e.g. valve) for Additional-stage heating.

- The group object contains the control value that the controller uses to control the output.

Additional-stage heating is controlled only via group object (no internal use):

- The group object sends the control value for controlling a different actuator.

Note

Depending on the input group objects of the actuator, it could be necessary to change the output of the control value between 1 byte and 1 bit. This is performed via the parameters described above.

Cyclical sending and sending on change of the group object can be set under Extended settings in the Room thermostat – Basic-stage heating parameter window.

| | | | | | |
|----|---|----------------------|-------|-----------|---------|
| 71 | Status Control Value Additional-stage heating | Channel – Controller | 1 bit | DPT 1.001 | C, R, T |
|----|---|----------------------|-------|-----------|---------|

See above

| | | | | | |
|----|--|----------------------|--------|-----------|---------|
| 72 | Status Control Value Basic-stage cooling | Channel – Controller | 1 byte | DPT 5.001 | C, R, T |
|----|--|----------------------|--------|-----------|---------|

The group object is enabled if Deactivated was not selected for the parameter Basic-stage cooling in the Application parameters parameter window.

The group object data point type depends on the selected application and the associated control.

Output is via a 1-byte value (DPT 5.001) when the following control types are selected:

- 2-point 1 byte (0/100 %)
- PI continuous (0...100 %)
- PI continuous (0...100 %) for Fan Coil

Output is via a 1-bit value (DPT 1.001) when the following control types are selected:

- 2-point 1 bit (On/Off)
- PI PWM (On/Off)

The control type is preselected by the parameter in Parameter Additional-stage cooling in this case. A certain type of control is preset depending on the selected application. The control type is freely selectable if Free configuration is selected in this parameter.

This group object outputs the control value for Basic-stage cooling.

Use of a physical device output (e.g. valve) for Basic-stage cooling.

- The group object contains the control value that the controller uses to control the output.

Basic-stage cooling is controlled only via group object (no internal use):

- The group object sends the control value for controlling a different actuator.

Note

KNX Technical Reference Manual

ABB i-Bus® KNX Caldion®

| | | | | | |
|--|---|----------------------|--------|-----------|------------|
| Depending on the input group objects of the actuator, it could be necessary to change the output of the control value between 1 byte and 1 bit. This is performed via the parameters described above. Cyclical sending and sending on change of the group object can be set under Extended settings in the Room thermostat – Basic-stage heating parameter window. | | | | | |
| 72 | Status Control Value Basic-stage cooling | Channel – Controller | 1 bit | DPT 1.001 | C, R, T |
| See above | | | | | |
| 73 | Status Control Value Additional-stage cooling | Channel – Controller | 1 byte | DPT 5.001 | C, R, T |
| <p>The group object is enabled if "Deactivated" was not selected for the parameter "Additional-stage cooling" in the "Application parameters" parameter window.</p> <p>The group object data point type depends on the selected application and the associated control.</p> <p>Output is via a 1-byte value (DPT 5.001) when the following control types are selected:</p> <ul style="list-style-type: none"> • 2-point 1 byte (0/100 %) • PI continuous (0...100 %) • PI continuous (0...100 %) for Fan Coil <p>Output is via a 1-bit value (DPT 1.001) when the following control types are selected:</p> <ul style="list-style-type: none"> • 2-point 1 bit (On/Off) • PI PWM (On/Off) <p>The control type is preselected by the parameter Additional-stage cooling in this case. A certain type of control is preset depending on the selected application. The control type is freely selectable if Free configuration is selected in this parameter.</p> <p>This group object outputs the control value for Additional-stage cooling.</p> <p>Use of a physical device output (e.g. valve) for Additional-stage cooling.</p> <ul style="list-style-type: none"> • The group object contains the control value that the controller uses to control the output. <p>Additional-stage cooling is controlled only via group object (no internal use):</p> <ul style="list-style-type: none"> • The group object sends the control value for controlling a different actuator. <p>Note Depending on the input group objects of the actuator, it could be necessary to change the output of the control value between 1 byte and 1 bit. This is performed via the parameters described above. Cyclical sending and sending on change of the group object can be set under Extended settings in the Room thermostat – Basic-stage heating parameter window.</p> | | | | | |
| 73 | Status Control Value Additional-stage cooling | Channel – Controller | 1 bit | DPT 1.001 | C, R, T |
| See above | | | | | |
| 75 | Actual temperature | Channel – Controller | 2 byte | DPT 9.001 | C, R, T |
| <p>This group object is always enabled.</p> <p>This group object indicates the current actual temperature value (room temperature) that the controller is using.</p> <p>This value consists of the value(s) measured via the physical device inputs and the values received via the two group objects External temperature 1 and External temperature 2.</p> <p>The values recorded via the inputs are averaged, and this mean value is then combined with the values received via the group object. A weighting factor can be defined for the combination process.</p> <p>The transmission reaction of this group object is set in the Room thermostat parameter window.</p> <p>Note This group object can also be used for display on analog room control units and visual display systems.</p> | | | | | |
| 76 | External temperature 1 | Channel – Controller | 2 byte | DPT 9.001 | C, W, T, U |
| <p>This group object is enabled if the parameter Temperature input is set to Via group object or Via physical device input + internal measurement + GO in the Application parameters parameter window.</p> <p>This group object can receive a temperature value via the KNX bus to be included in determining the actual temperature (room temperature). This group object value is evaluated after the device is restarted.</p> | | | | | |
| 77 | External temperature 2 | Channel – Controller | 2 byte | DPT 9.001 | C, W, T, U |
| <p>This group object is enabled if the parameter Temperature input is set to Via group object or Via physical device input + internal measurement + GO and the Number of temperature input objects is set to 2 in the Application parameters parameter window.</p> <p>This group object cannot be activated in actuator mode.</p> <p>This group object can receive a temperature value via the KNX bus to be included in determining the actual temperature (room temperature). This group object value is evaluated after the device is restarted.</p> | | | | | |
| 78 | Fault: actual temperature (master) | Channel – Controller | 1 bit | DPT 1.002 | C, R, T |
| <p>This group object if the parameter Temperature input monitoring is not set to Deactivated in the Monitoring and safety parameter window.</p> <p>This group object cannot be activated in actuator mode.</p> <p>If the temperature monitoring time of the input is exceeded or if a fault is found on the monitored input, the group object changes the status to 1 to indicate the fault.</p> <p>This group object is sent on every status change.</p> <p>Telegram value:</p> <ul style="list-style-type: none"> • 0: No fault • 1: Fault: actual temperature | | | | | |
| 79 | Current setpoint | Channel – Controller | 2 byte | DPT 9.001 | C, R, T |
| <p>The group object outputs the current setpoint temperature value.</p> <p>This consists of the current operating mode and the manual setpoint adjustment.</p> | | | | | |

KNX Technical Reference Manual

ABB i-Bus® KNX Caldion®

The group object is controlled by manually changing the setpoint or by changing the operating mode, the basic setpoint temperature and the setpoint temperature for the individual operating modes.

| | | | | | |
|---|----------------------------------|----------------------|--------|------------|------------|
| 80 | Operating mode normal (master) | Channel – Controller | 1 byte | DPT 20.102 | C, W, T, U |
| <p>The group object receives the operating mode to be set as a 1-byte value.</p> <p>Telegram value:</p> <ul style="list-style-type: none"> • 1: Comfort • 2: Standby • 3: Economy • 4: Frost/heat protection <p>The operating mode switches between different operating states of the room:</p> <ul style="list-style-type: none"> • Comfort: Room occupied. The setpoint temperature is set to a default value perceived as pleasant by most users. • Standby: Room is briefly/recently vacant. The setpoint temperature is decreased (heating) or increased (cooling) • Economy: The room is unused for an extended period (e.g. overnight), and the temperature is markedly decreased (heating) or increased (cooling). • Frost/heat protection: The room or building is unused for an extended period (e.g. school during vacation). The setpoint temperatures are adjusted to the minimum (heating – frost protection) or maximum (cooling – heat protection) values that are still acceptable without damaging the installation. <p>Switchover between the operating modes usually takes place via a central schedule or via Intelligent Building Control.</p> <p>The group objects and states Override mode, Fill level alarm, Dew point alarm, Window contact, Request On/Off (Master), Presence detector and Operating mode (listed in decreasing priority) determine the controller's setpoint in addition to manual setpoint adjustment and basic setpoint adaptation.</p> | | | | | |
| 81 | Operating mode override (master) | Channel – Controller | 1 byte | DPT 20.102 | C, W, T, U |
| <p>The group object receives the operating mode to be set as a 1-byte value.</p> <p>Telegram value:</p> <ul style="list-style-type: none"> • 0: Automatic/no override • 1: Comfort • 2: Standby • 3: Economy • 4: Frost/heat protection <p>The group object overrides the room's operating mode. The operating mode set here overrides all other priorities except for the reaction on bus voltage failure.</p> <p>For example, this group object can override a malfunction on a connected sensor (e.g. faulty window contact) that would actually cause the operating mode to change.</p> <p>Note</p> <p>For the device to function normally and react normally to adjustment by the user, this group object must be set to the value 0 Automatic/no override.</p> <p>The group objects and states Override mode, Fill level alarm, Dew point alarm, Window contact, Request On/Off (Master), Presence detector and Operating mode (listed in decreasing priority) determine the controller's setpoint in addition to manual setpoint adjustment and basic setpoint adaptation.</p> | | | | | |
| 82 | Window contact (master/slave) | Channel – Controller | 1 bit | DPT 1.019 | C, W |
| <p>This group object is enabled if the parameter Window status input is set to Via group object in the Application parameters parameter window.</p> <p>This group object can receive the window status via KNX.</p> <p>Telegram value:</p> <ul style="list-style-type: none"> • 0: Window closed • 1: Window open <p>This group object changes the device's operating mode to frost/heat protection when the "window open" information is received. A higher-priority group object can override the operating mode.</p> <p>Note</p> <p>The group objects and states Override mode, Fill level alarm, Dew point alarm, Window contact, Request On/Off (Master), Presence detector and Operating mode (listed in decreasing priority) determine the controller's setpoint in addition to manual setpoint adjustment and basic setpoint adaptation.</p> | | | | | |
| 83 | Presence detector (master/slave) | Channel – Controller | 1 bit | DPT 1.018 | C, W |
| <p>This group object can receive the presence status (person in the room) via KNX.</p> <p>Telegram value:</p> <ul style="list-style-type: none"> • 0: Room vacant • 1: Room occupied <p>When the presence information is received, this group object changes the device's operating mode to Comfort.</p> <p>When the room vacant information is received the operating mode is set back to the operating mode set via the group object Operating mode. A higher-priority group object can override the operating mode.</p> | | | | | |
| 84 | Status Heating | Channel – Controller | 1 bit | DPT 1.001 | C, R, T |
| <p>This group object is enabled if the controller was parametrized for heating. For this purpose, Deactivated must not be selected for the parameter Basic-stage heating in the Application parameters parameter window.</p> <p>This group object is hidden in actuator mode.</p> <p>The device uses the group object to indicate whether it is currently active in the operating mode, i.e. whether the control value is greater than 0.</p> <p>Telegram value:</p> | | | | | |

KNX Technical Reference Manual

ABB i-Bus® KNX Caldion®

| | | | | | |
|--|---|----------------------|--------|-----------|------------|
| <ul style="list-style-type: none"> • 0: Heating control value = 0 • 1: Heating control value > 0 | | | | | |
| 85 | Status Cooling | Channel – Controller | 1 bit | DPT 1.001 | C, R, T |
| <p>This group object is enabled if the controller was parametrized for cooling. For this purpose, Deactivated must not be selected for the parameter Basic-stage cooling in the Application parameters parameter window.</p> <p>This group object is hidden in actuator mode.</p> <p>The device uses the group object to indicate whether it is currently active in the operating mode, i.e. whether the control value is greater than 0.</p> <p>Telegram value:</p> <ul style="list-style-type: none"> • 0: Cooling control value = 0 • 1: Cooling control value > 0 | | | | | |
| 86 | Activate minimum control value (basic load) | Channel – Controller | 1 bit | DPT 1.003 | C, W |
| <p>The group object is enabled if the parameter Minimum control value for basic load > 0 is set to Activate via group object in the Temperature controller parameter window.</p> <p>This group object is hidden in actuator mode.</p> <p>Sending the value 1 on this group objects activates the basic load.</p> <p>The basic load is a minimum control value that must not be fallen below. The basic-load value can be defined for each heating and cooling stage, but only for control types for which the control value is output with 0...100 %.</p> <p>The basic load is always activated jointly for all stages, but it is active only for the active heating or cooling mode in each case.</p> <p>The control value can decrease to 0 % again when the basic load is inactive.</p> <p>One sample application for the basic load is floor heating, for which a certain control value must not be fallen below to protect the installation.</p> <p>Telegram value:</p> <ul style="list-style-type: none"> • 0: Basic load inactive • 1: Basic load active | | | | | |
| 87 | Heating/Cooling changeover | Channel – Controller | 1 bit | DPT 1.100 | C, W, T, U |
| <p>This group object is enabled if the controller was parametrized for both heating and cooling. For this purpose, Deactivated must not be selected for the parameters Basic-stage heating and Basic-stage cooling in the Application parameters parameter window.</p> <p>Additionally, the parameter Heating/Cooling changeover must be set to Only via group object or Via slave or group object.</p> <p>This group object changes between heating and cooling modes.</p> <p>If Via slave and via object is selected, changeover can be performed either via this group object or via the control option of a slave. The current operating mode can be changed via the group object at any time.</p> <p>Telegram value:</p> <ul style="list-style-type: none"> • 0: Cooling • 1: Heating | | | | | |
| 88 | Base setpoint | Channel – Controller | 2 byte | DPT 9.001 | C, W |
| <p>The group object is enabled if the parameter Setpoint specification and adjustment is set to Relative in the Setpoint manager parameter window.</p> <p>This group object can change the parametrized basic setpoint. This can shift the the setpoints assigned to the individual operating modes (Comfort, Standby, Economy). The relative distances between the setpoints remain the same, the the Comfort value is shifted accordingly.</p> <p>Depending on the selection in the parameter Base setpoint is, the base setpoint is the Comfort heating setpoint, Comfort cooling setpoint or the Mean value between Comfort heating and Comfort cooling.</p> <p>The basic setpoint is set to the temperature value received via this group object. However, the value must not lie outside the value range valid for the basic setpoint (10...40 °C).</p> <p>The setpoint temperatures for frost and heat protection remain unaffected by this change.</p> | | | | | |
| 89 | Reset manual setpoint adjustment | Channel – Controller | 1 bit | DPT 1.017 | C, W |
| <p>This group object is enabled if the parameter Connection of an analog room control unit to physical device input a in the Setpoint adjustment parameter window is set to No.</p> <p>This group object can reset the setpoint adjustment performed via KNX (via the group object Request setpoint adjustment). Activating this group object resets the setpoints to the parametrized setpoints.</p> | | | | | |
| 90 | Dew point alarm | Channel – Controller | 1 bit | DPT 1.005 | C, W |
| <p>This group object is enabled if the parameter Dew point status input is set to Via group object in the Application parameters parameter window.</p> <p>The device must be parametrized for cooling or heating mode for this parameter to be visible.</p> <p>This group object can receive the dew point status via KNX.</p> <p>Telegram value:</p> <ul style="list-style-type: none"> • 0: Dew point alarm inactive • 1: Dew point alarm active <p>When the dew point alarm information is received, this group object changes the device's operating mode to heat protection to protect the building.</p> <p>Dew formation, which occurs when reaching the dew point temperature, can damage the building substance.</p> <p>The alarm is valid as long as the device is in cooling mode or until the alarm is canceled by reception of the value 0.</p> <p>The operating mode is recalculated when changing to Heating mode. Heating can take place as normal, because the dew point is not a problem during heating.</p> <p>A higher-priority group object can override the operating mode.</p> | | | | | |

KNX Technical Reference Manual

ABB i-Bus® KNX Caldion®

The group objects and states Override mode, Fill level alarm, Dew point alarm, Window contact, Request On/Off (Master), Presence detector and Operating mode (listed in decreasing priority) determine the controller's setpoint in addition to manual setpoint adjustment and basic setpoint adaptation.

| | | | | | |
|---|---|----------------------|--------|-----------|---------|
| 91 | Fill level alarm | Channel – Controller | 1 bit | DPT 1.005 | C, W |
| <p>This group object is enabled if the parameter Fill level sensor input is set to Via group object in the Application parameters parameter window.</p> <p>The device must be parametrized for cooling or heating mode for this parameter to be visible.</p> <p>This group object is hidden in actuator mode.</p> <p>This group object can receive the fill level status via KNX.</p> <p>Telegram value:</p> <ul style="list-style-type: none"> • 0: Fill level alarm inactive • 1: Fill level alarm active <p>When the fill level alarm information is received, this group object changes the device's operating mode to heat protection to protect the building.</p> <p>The fill level alarm message means that the fill level in the condensate tray has exceeded a predefined limit. More condensate formation would cause the condensate tray to overflow and thereby damage the building.</p> <p>The alarm is valid as long as the device is in cooling mode or until the alarm is canceled by reception of the value 0.</p> <p>The operating mode is recalculated when changing to Heating mode. Heating can take place as normal, because the dew point is not a problem during heating.</p> <p>A higher-priority group object can override the operating mode.</p> <p>The group objects and states Override mode, Fill level alarm, Dew point alarm, Window contact, Request On/Off (Master), Presence detector and Operating mode (listed in decreasing priority) determine the controller's setpoint in addition to manual setpoint adjustment and basic setpoint adaptation.</p> | | | | | |
| 92 | Outside temperature for summer compensation | Channel – Controller | 2 byte | DPT 9.001 | C, W |
| <p>This group object is enabled if the parameter Summer compensation in the Setpoint management parameter window is parametrized with Yes.</p> <p>This group object receives the outside temperature so that the device can check whether or not summer compensation must be active. For this purpose, a starting temperature from which summer compensation must become active is set using a parameter.</p> | | | | | |
| 93 | Summer compensation active/inactive | Channel – Controller | 1 bit | DPT 1.002 | C, R, T |
| <p>This group object is enabled if the parameter Summer compensation in the Setpoint management parameter window is parametrized with Yes.</p> <p>This group object indicates whether summer compensation is active.</p> <p>Telegram value:</p> <ul style="list-style-type: none"> • 0: Summer compensation inactive • 1: Summer compensation active | | | | | |
| 94 | Setpoint reached | Channel – Controller | 1 bit | DPT 1.002 | C, R, T |
| <p>This group object signals on the bus that the set setpoint has been reached in Comfort mode. The function is started by activating Comfort or Presence mode.</p> <p>This group object value is 0 as long as the setpoint has not been reached.</p> <p>The state changes from 1 to 0 when switching over to another operating mode or setting a new setpoint.</p> <p>Telegram value:</p> <ul style="list-style-type: none"> • 0: Comfort setpoint not reached | | | | | |
| 95 | Request On/Off (master) | Channel – Controller | 1 bit | DPT 1.001 | C, W |
| <p>This group object can switch the controller off. The controller changes to frost/heat protection operating mode when the value 0 is received. This causes control to switch off (except if the frost/heat protection temperatures have already been reached). All control values are set to 0.</p> <p>The device activates itself automatically when the frost/heat protection temperatures are reached.</p> <p>Control can also be reactivated by sending the value 1 on this group object.</p> <p>Additionally, the slave can use this group object to request the controller (master) to switch of control. Switch off and non-switch-off is confirmed via the group object Confirm On/Off (master).</p> <p>Telegram value:</p> <ul style="list-style-type: none"> • 0: Deactivate control (Off) • 1: Activate control (On) | | | | | |
| 96 | Confirm On/Off (master) | Channel – Controller | 1 bit | DPT 1.001 | C, R, T |
| <p>The device signals whether control is active (On) or inactive (Off) using this group object.</p> <p>Telegram value:</p> <ul style="list-style-type: none"> • 0: Control active (On) • 1: Control inactive (Off) | | | | | |
| 97 | Setpoint display (master) | Channel – Controller | 2 byte | DPT 9.002 | C, R, T |
| <p>This group object synchronizes between the controller (master) and the slave. This group object must be connected to the slave's group object of the same name for this purpose.</p> <p>This group object transmits the setpoint to be displayed.</p> | | | | | |
| 98 | Request setpoint adjustment (master) | Channel – Controller | 2 byte | DPT 9.001 | C, W |
| <p>The group object transmits a setpoint change between the controller (master) and the slave or any other device.</p> <p>This group object can adjust setpoints within the permitted limits.</p> <p>The group object's data point type depends on the data point type selected in the parameter Manual setpoint adjustment via KNX with in the Setpoint adjustment parameter window.</p> | | | | | |

KNX Technical Reference Manual

ABB i-Bus® KNX Caldion®

The type of DPTs used can be selected to ensure usability of setpoint adjustment with other devices as well.
DPT 6.010 must be selected for existing systems and for ABB devices that do not use the current controller version (ClimaECO master/slave concept) yet. With this method, the temperature is converted to an integer value before it is sent and the adjustment is transmitted in steps.

With newer devices, the DPTs 9.001 or 9.002 can be selected for the purpose of absolute or relative setpoint adjustment via temperature values.

The setpoint temperature (e.g. 22 °C) or the change in the setpoint temperature (z.B. +2 °C) must be sent to the group object for this purpose.

Note

All ABB devices still support adjustment via DPT 6.010.

If the required temperature is outside the permitted setpoint range, the maximum/minimum possible value will be set. For this purpose, the master device checks the received value and returns the set value via the group object Confirm setpoint adjustment (master).

| | | | | | |
|--|--------------------------------------|----------------------|--------|------------|---------|
| 98 | Request setpoint adjustment (master) | Channel – Controller | 2 byte | DPT 9.002 | |
| See above | | | | | |
| 98 | Request setpoint adjustment (master) | Channel – Controller | 1 byte | DPT 6.010 | |
| See above | | | | | |
| 99 | Confirm setpoint adjustment (master) | Channel – Controller | 2 byte | DPT 9.001 | C, R, T |
| The group object transmits a setpoint change between the controller (master) and the slave or any other device. This group object confirms a setpoint adjustment requested via the group object Request setpoint adjustment so that the new value becomes known to the requesting device as well. Refer to group object 95 for the various data point types. The data point type of this group object depends on the same settings. | | | | | |
| 99 | Confirm setpoint adjustment (master) | Channel – Controller | 2 byte | DPT 9.002 | |
| See above | | | | | |
| 99 | Confirm setpoint adjustment (master) | Channel – Controller | 1 byte | DPT 6.010 | |
| See above | | | | | |
| 100 | Request heating/cooling (master) | Channel – Controller | 1 bit | DPT 1.100 | C, W |
| This group object synchronizes between the controller (master) and the slave. This group object must be connected to the slave's group object of the same name for this purpose. The group object synchronizes the heating/cooling status between the controller (master) and the slave. | | | | | |
| 101 | Request fan manually (master) | Channel – Controller | 1 bit | DPT 1.001 | C, W |
| This group object requests changing out of/into fan automation. The group object must be connected to the controller's (master's) group object of the same name for this purpose. | | | | | |
| 102 | Confirm fan manually (master) | Channel – Controller | 1 bit | DPT 1.001 | C, R, T |
| The controller (master) uses this group object to inform the actuator (slave) whether changeover to fan automation or from fan automation has taken place. | | | | | |
| 103 | Request fan speed (master) | Channel – Controller | 1 byte | DPT 5.001 | C, W |
| The group object transmits a change in the fan speed between the controller (master) and the slave or any other device. The group object's data point type depends on the data point type selected in the parameter Manual fan speed adjustment via KNX with in the Setpoint adjustment parameter window. The type of DPT used can be selected to ensure usability of fan speed adjustment with other devices as well. DPT 5.010 must be selected for existing systems and for ABB devices that do not use the current controller version (ClimaECO master/slave concept) yet. The fan speed adjustment is transmitted in steps with this method. DPT 5.001 can be selected on newer devices, and the fan speed thereby can be transmitted directly as a percentage. | | | | | |
| 103 | Request fan speed (master) | Channel – Controller | 1 byte | DPT 5.010 | |
| See above | | | | | |
| 104 | Confirm fan speed (master) | Channel – Controller | 1 byte | DPT 5.001 | C, R, T |
| The group object transmits a change in the fan speed between the controller (master) and the slave or any other device. The controller (master) uses this group object to inform the connected devices whether the requested fan speed is permitted or to inform them about the current fan speed. Refer to group object 100 for the various data point types. The data point type of this group object depends on the same settings. | | | | | |
| 104 | Confirm fan speed (master) | Channel – Controller | 1 byte | DPT 5.010 | |
| See above | | | | | |
| 105 | Controller RHCC status | Channel – Controller | 2 byte | DPT 22.101 | C, R, T |
| The group object outputs the heating/cooling operating mode, active/inactive operation, frost and heat alarm, as well as any malfunction (failure of actual temperature measurement) according to the specification for the RHCC (Room Heating Cooling Controller) status. | | | | | |
| 106 | Controller HVAC status (master) | Channel – Controller | 1 byte | DPT 5.001 | C, R, T |
| This group object must be connected to the slave's group object of the same name. The group object synchronizes between the controller (master) and the slave. The group object transmits the current operating mode, heating/cooling operating mode, active/inactive operation, frost alarm and the dew point alarm to the slave. The group object synchronizes the heating/cooling status between the controller (master) and the slave. | | | | | |

KNX Technical Reference Manual
ABB i-Bus® KNX Cالدion®

| | | | | | |
|---|--------------------------------------|----------------------|--------|------------|---------|
| 107 | Current HVAC operating mode | Channel – Controller | 1 bit | DPT 20.102 | C, R, T |
| <p>This group object outputs the currently valid HVAC operating mode after evaluation of all priorities and influences. The group object indicates the current controller operating mode. The group object sends the current operating mode as a 1-byte value. Telegram value: • 1: Comfort • 2: Standby • 3: Economy • 4: Frost/heat protection</p> | | | | | |
| 108 | Comfort heating setpoint | Channel – Controller | 2 byte | DPT 9.001 | C, W |
| <p>This group object is enabled if the parameter Setpoint specification and adjustment is set to Absolute and Comfort heating setpoint = Comfort cooling setpoint is set to No in the Setpoint manager parameter window. This group object can directly influence and overwrite the stored setpoint for Comfort heating. The value received via this group object is permanently stored and serves as the new Comfort heating setpoint. Manual setpoint adjustment acts on this setpoint. The value must lie in the valid value range of 10...40 °C. A value outside this range is limited to this range.</p> | | | | | |
| 108 | Comfort heating/cooling setpoint | Channel – Controller | 2 byte | DPT 9.001 | C, W |
| <p>This group object is enabled if the parameter Setpoint specification and adjustment is set to Absolute and the parameter Comfort heating setpoint = Comfort cooling setpoint is set to Yes in the Setpoint manager parameter window. This group object can directly influence and overwrite the stored setpoint for Comfort heating and cooling. The value received via this group object is permanently stored and serves as the new Comfort heating and cooling setpoint. Manual setpoint adjustment acts on this setpoint. The value must lie in the valid value range of 10...40 °C. A value outside this range is limited to this range.</p> | | | | | |
| 109 | Comfort cooling setpoint | Channel – Controller | 2 byte | DPT 9.001 | C, W |
| <p>This group object is enabled if the parameter Setpoint specification and adjustment is set to Absolute and Comfort heating setpoint = Comfort cooling setpoint is set to No in the Setpoint manager parameter window. This group object can directly influence and overwrite the stored setpoint for Comfort cooling. The value received via this group object is permanently stored and serves as the new Comfort cooling setpoint. Manual setpoint adjustment acts on this setpoint. The value must lie in the valid value range of 10...40 °C. A value outside this range is limited to this range.</p> | | | | | |
| 110 | Economy heating setpoint | Channel – Controller | 2 byte | DPT 9.001 | C, W |
| <p>This group object is enabled if the parameter Setpoint specification and adjustment in the Setpoint manager parameter window is parametrized with Absolute. This group object can directly influence and overwrite the stored setpoint for Economy heating. The value received via this group object is permanently stored and serves as the new Economy heating setpoint. Manual setpoint adjustment acts on this setpoint. The value must lie in the valid value range of 10...40 °C. A value outside this range is limited to this range. The value must be less than the value for comfort heating. If a value is not below this value, the device will automatically classify it below this value.</p> | | | | | |
| 111 | Economy cooling setpoint | Channel – Controller | 2 byte | DPT 9.001 | C, W |
| <p>This group object is enabled if the parameter Setpoint specification and adjustment in the Setpoint manager parameter window is parametrized with Absolute. This group object can directly influence and overwrite the stored setpoint for Economy cooling. The value received via this group object is permanently stored and serves as the new Economy cooling setpoint. Manual setpoint adjustment acts on this setpoint. The value must lie in the valid value range of 10...40 °C. A value outside this range is limited to this range. The value must be greater than the value for comfort cooling. If a value is not below this value, the device will automatically classify it below this value.</p> | | | | | |
| 112 | Standby heating setpoint | Channel – Controller | 2 byte | DPT 9.001 | C, W |
| <p>This group object is enabled if the parameter Setpoint specification and adjustment in the Setpoint manager parameter window is parametrized with Absolute. This group object can directly influence and overwrite the stored setpoint for Standby heating. The value received via this group object is permanently stored and serves as the new Standby heating setpoint. Manual setpoint adjustment acts on this setpoint. The value must lie in the valid value range of 10...40 °C. A value outside this range is limited to this range. The value must be less than the value for comfort heating. If a value is not below this value, the device will automatically classify it below this value.</p> | | | | | |
| 113 | Standby cooling setpoint | Channel – Controller | 2 byte | DPT 9.001 | C, W |
| <p>This group object is enabled if the parameter Setpoint specification and adjustment in the Setpoint manager parameter window is parametrized with Absolute. This group object can directly influence and overwrite the stored setpoint for Standby cooling. The value received via this group object is permanently stored and serves as the new Standby cooling setpoint. Manual setpoint adjustment acts on this setpoint. The value must lie in the valid value range of 10...40 °C. A value outside this range is limited to this range. The value must be greater than the value for comfort cooling. If a value is not below this value, the device will automatically classify it below this value.</p> | | | | | |
| 114 | Building protection heating setpoint | Channel – Controller | 2 byte | DPT 9.001 | C, W |
| <p>This group object is enabled if the parameter Setpoint specification and adjustment in the Setpoint manager parameter window is parametrized with Absolute. This group object can directly influence and overwrite the stored setpoint for building protection heating (frost protection). The value received via this group object is permanently stored and serves as the new building protection heating setpoint. Manual setpoint adjustment acts on this setpoint.</p> | | | | | |

KNX Technical Reference Manual
ABB i-Bus® KNX Caldion®

| | | | | | |
|--|--|----------------------|--------|-----------|------------|
| The value must lie in the valid value range of 5...15 °C. A value outside this range is limited to this range. The value must be less than the value for comfort heating. If a value is not below this value, the device will automatically classify it below this value. | | | | | |
| 115 | Building protection cooling setpoint | Channel – Controller | 2 byte | DPT 9.001 | C, W |
| This group object can directly influence and overwrite the stored setpoint for building protection cooling (heat protection). The value received via this group object is permanently stored and serves as the new building protection cooling setpoint. Manual setpoint adjustment acts on this setpoint. The value must lie in the valid value range of 27...45 °C. A value outside this range is limited to this range. The value must be greater than the value for comfort cooling. If a value is not below this value, the device will automatically classify it below this value. | | | | | |
| 118 | Basic-stage heating limit temperature | Channel – Controller | 2 byte | DPT 9.001 | C, W, T, U |
| This group object is enabled if the parameter Activate temperature limitation is set to Yes in the Temperature controller – Basic-stage heating parameter window and the parameter Input for limit temperature sensor is set to Via group object. This group object receives the limit temperature for Basic-stage heating. The temperature value received here is used to evaluate the limit temperature. The limit becomes active when the temperature set in the parameter Limit temperature is exceeded. | | | | | |
| 119 | Additional-stage heating limit temperature | Channel – Controller | 2 byte | DPT 9.001 | C, W, T, U |
| This group object is enabled if the parameter Activate temperature limitation is set to Yes in the Temperature controller – Additional-stage heating parameter window and the parameter Input for limit temperature sensor is set to Via group object. This group object receives the limit temperature for Additional-stage heating. The temperature value received here is used to evaluate the limit temperature. The limit becomes active when the temperature set in the parameter Limit temperature is exceeded. | | | | | |
| 120 | Basic-stage cooling limit temperature | Channel – Controller | 2 byte | DPT 9.001 | C, W, T, U |
| This group object is enabled if the parameter Activate temperature limitation is set to Yes in the Temperature controller – Basic-stage cooling parameter window and the parameter Input for limit temperature sensor is set to Via group object. This group object receives the limit temperature for Basic-stage cooling. The temperature value received here is used to evaluate the limit temperature. The limit becomes active when the temperature set in the parameter Limit temperature is fallen below. | | | | | |
| 121 | Additional-stage cooling limit temperature | Channel – Controller | 2 byte | DPT 9.001 | C, W, T, U |
| This group object is enabled if the parameter Activate temperature limitation is set to Yes in the Temperature controller – Additional-stage cooling parameter window and the parameter Input for temperature limit sensor is set to Via group object. This group object receives the limit temperature for Additional-stage cooling. The temperature value received here is used to evaluate the limit temperature. The limit becomes active when the temperature set in the parameter Limit temperature is fallen below. | | | | | |
| 123 | Door open when | Channel – Controller | 1 bit | DPT 1.019 | C, W |
| This group object is enabled if the parameter Occupancy presence detection logic and door contact detection via group object is activated Depending on the selected parametrization, this group object indicates the state of the door open detect from the bus | | | | | |
| 124 | Presence detect when | Channel – Controller | 1 bit | DPT 1.001 | C, W |
| This group object is enabled if the parameter Occupancy presence detection logic and presence detection via group object is activated Depending on the selected parametrization, this group object indicates the state of the presence detect from the bus | | | | | |
| 125 | Room occupancy status | Channel – Controller | 1 bit | DPT 1.018 | C, R, T |
| This group object is enabled if the parameter Occupancy presence detection logic is activated Depending on the status from “door open when” and “presence detect when”, this group object indicates the status of guest in the room into the bus. | | | | | |
| 126 | Request Fan only mode | Channel – Controller | 1 bit | DPT 1.001 | C, W |
| This group object is enabled if the parameter Fan only mode is activated This group enable Fan only mode to be activate or deactivate via group object | | | | | |
| 127 | Confirm Fan only mode | Channel – Controller | 1 bit | DPT 1.001 | C, R, T |
| This group object is enabled if the parameter Fan only mode is activated This group object transmits a change in the fan only mode status, the controller used this group object to inform the connected devices whether the requested fan only mode is permitted or to inform them about the fan only mode status | | | | | |

14 Information about planning and application

14.1 Room climate control

If a room climate control system is in place, it is possible to record and control the factors affecting whether the room air is of good quality. In this case, the KNX bus is provide with data relating to air quality and room temperature control. If the CO₂ concentration level in the room is too high, for example, it is possible to have ventilators switched on or windows opened automatically. The air quality in the room is constantly recorded and monitored. There is no need to intervene in the process – everything happens automatically.

A room climate control system is often used in rooms where the number of people varies within a small space, such as supermarkets, shopping centers, hotels, cinemas, hospitals and schools. Application examples and practical tips on the topic of temperature control, valve drives, characteristic curve adjustment, etc., can be found in the Application manual Heating/Ventilation/Air-Conditioning at <https://www.abb.com/knx>



Service

ABB LV Installation Materials Co.,
Ltd. Beijing 北京 ABB 低压电器有限公司
No 17 Kangding Street, BDA, Beijing

<http://www.abb.com.cn>,
Tel: +86 400-820-9696

Notice

We reserve the right to make technical changes at all times as well as changes to the contents of this document without prior notice.

The detailed specifications agreed upon apply for orders. ABB accepts no responsibility for possible errors or incompleteness in this document.

We reserve all rights to this document and the topics and illustrations contained therein. The document and its contents, or extracts thereof, must not be reproduced, transmitted or reused by third parties without prior written consent by ABB

Copyright© 2019 ABB
All rights reserved