

IP room controller

Catalogue number(s): 0 484 08

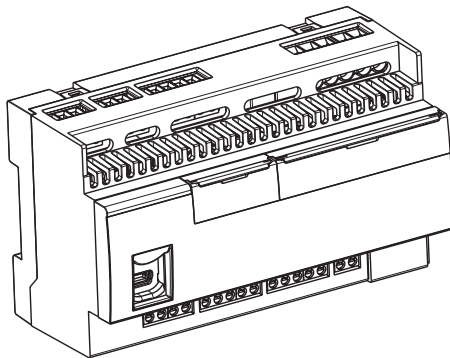

CONTENTS

Page

1. Use	1
2. Technical features	1
3. Wiring	3
4. Parameter setting.....	6
5. Maintenance	6
6. Standards	6

BACnet® is a registered trademark of ASHRAE.

1. Introduction

The IP modular controller Cat. No. 0 484 08 has been specially designed for controlling hotel rooms and meeting rooms. It can be powered by a PoE injector on the IP network or by an external power supply.

It comprises:

- 8 configurable auxiliary inputs for ON/OFF, Dim +/-, scene and up/down/ stop commands for roller blinds via switches, pushbuttons or other volt-free contact devices.
- 10 binary outputs that can be configured to control lighting (1 block of 4 relays: 4.3 A max.), blinds (2 blocks of 2 relays: 2.1 A max. to be distributed in each block) and socket outlets (1 block of 2 relays: 16 A max.).

Each output can be part of the various scenarios associated with conditional functions such as volt-free contacts, level of light or time programming.

Automatic presence management (Virtual Keycard) can determine whether the room is occupied by combining data from the motion sensors and the door contact.

A BUS/SCS connection can link the SCS actuators and control units to a customised interface, thus linking dimmers with various loads and controlling temperature regulation. The parameters are set in the software via the IP network. The self-configured outputs are supervised using the IP Bacnet protocol.

2. Technical features

2. Technical features (continued)

Device power supply	• RJ 45 (class 0 PoE/PoE+) or • Screw terminal block (27-50 V~/V=)
Number of load terminals	10 outputs { A - B: 2.1 A blocks C: 4.3 A blocks E: 16 A blocks
Number of auxiliary input terminals	8 inputs (G: one 8-input block)
Capacity of load terminals	2 x 1.5 mm ² (A to C) 2 x 2.5 mm ² (E)
Capacity of SCS terminals	1 x 2.5 mm ²
Contact type	Bistable relay (block E) and monostable relay (blocks A, B and C)
RJ 45	Auto MDI/MDI-X
Degree of protection	IP 20
Penetration by solid and liquid matter	(installation in an enclosure)
Impact resistance	IK 04
Number of modules	8
Usage temperature	-5°C to +45°C
Storage temperature	-20°C to +70°C
No-load power consumption	< 1 W
Weight	85 g

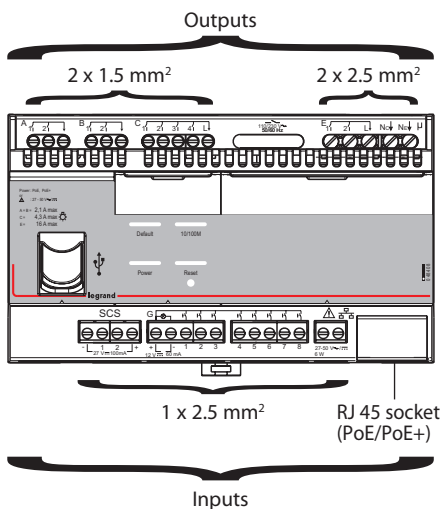

Dimensions

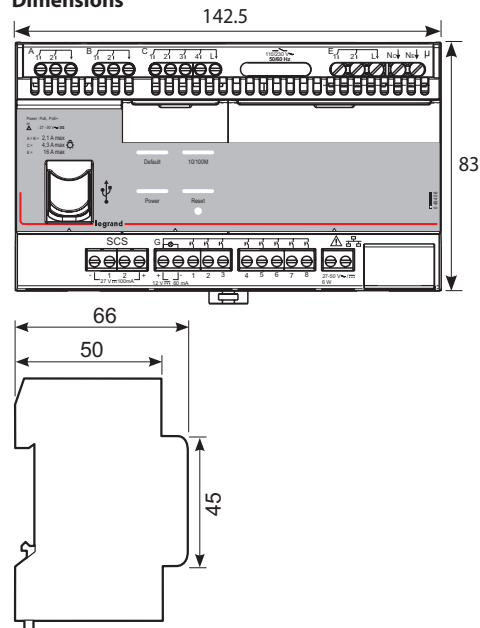

Neutral terminals allow:
- Synchronisation with the mains power supply

2. Technical features (continued)

	1		2		3		4		5		6		7		8		9		
Outputs A - B	230 V~	80 VA	0.3 A	250 VA	1.1 A	250 VA	1.1 A	2 (2 x 36) W	0.8 A	80 VA	0.3 A	80 VA	0.3 A	500 W	2.1 A	250 VA	1.1 A	250 VA	1.1 A
	110 V~	40 VA		125 VA		125 VA		1 (2 x 36) W		40 VA		40 VA		250 W		125 VA		125 VA	
	12 - 48 V~/V=	4-15 VA	0.3 A													13-52 VA	1.1 A	13-52 VA	1.1 A
Outputs C	230 V~	160 VA	0.7 A	500 VA	2.1 A	500 VA	2.1 A	4 (2 x 36) W	1.7 A	160 VA	0.7 A	160 VA	0.7 A	1000 W	4.3 A	500 VA	2.1 A	500 VA	2.1 A
	110 V~	80 VA		250 VA		250 VA		2 (2 x 36) W		80 VA		80 VA		500 W		250 VA		250 VA	
Outputs E	230 V~	500 VA	2.1 A	1000 VA	4.3 A	1000 VA	4.3 A	10 (2 x 36) W	4.3 A	500 VA	2.1 A	500 VA	2.1 A	3680 W	16 A	500 VA	2.1 A	500 VA	2.1 A
	110 V~	250 VA		500 VA		500 VA		5 (2 x 36) W		250 VA		250 VA		1760 W		250 VA		250 VA	

- 1 LED bulbs
- 2 ELV halogen, compact fluorescent and fluorescent bulbs with separate electronic ballast
- 3 ELV halogen, compact fluorescent and fluorescent bulbs with separate ferromagnetic ballast
- 4 Fluorescent tubes
- 5 Compact fluorescent bulbs with built-in electronic ballast
- 6 Compact fluorescent bulbs with built-in ferromagnetic ballast
- 7 Halogen bulbs
- 8 Motors
- 9 Contactors

Power supply unit

The controller must be powered by an external power supply. Permitted voltage range: 27 to 50 V~/=, 6 W min.

Power outputs

- Blocks A and B (2 blocks of 2 relays: 2.1 A max. to be distributed in each of the blocks).
For roller blind control functions, exclusive signs (e.g. Do Not Disturb/Make Up Room) and ON/OFF functions (for AC or DC load).
- Block C (1 block of 4 relays: 4.3 A max.). For controlling 4 separate loads.
- Block E (1 block of 2 relays: 16 A max.). For controlling 2 separate loads.

Control inputs

- Block G

The controller has a block comprising 1 power supply output (12 V=) and 8 auxiliary inputs. The inputs can take switches or pushbuttons for issuing commands such as ON/OFF, dimming, up/down, scenarios whose parameters are set using the configuration software.

The power supply enables the controls to have pilot lights (standby).

SCS output

This block has a power supply output (+, -) which can be used to power the bus if necessary and the SCS communication BUS (1, 2).

The internal power supply can provide a maximum of 100 mA on the bus.

This self-powered option is achieved by bridging.

If it is necessary to connect more than 100 mA of peripheral equipment, an external SCS power supply can be added to the bus.

In this case you must remove the internal power supply.

On the BUS/SCS, the controls, actuators, dimmers, thermostats and sensors can be configured and associated with scenarios by the configuration software.

IP unit

The controller has an IP communication connection and also a Power Over Ethernet connection to supply it with power.

The controller can operate at 10 or 100 Mbps.

3. Wiring

• Single phase

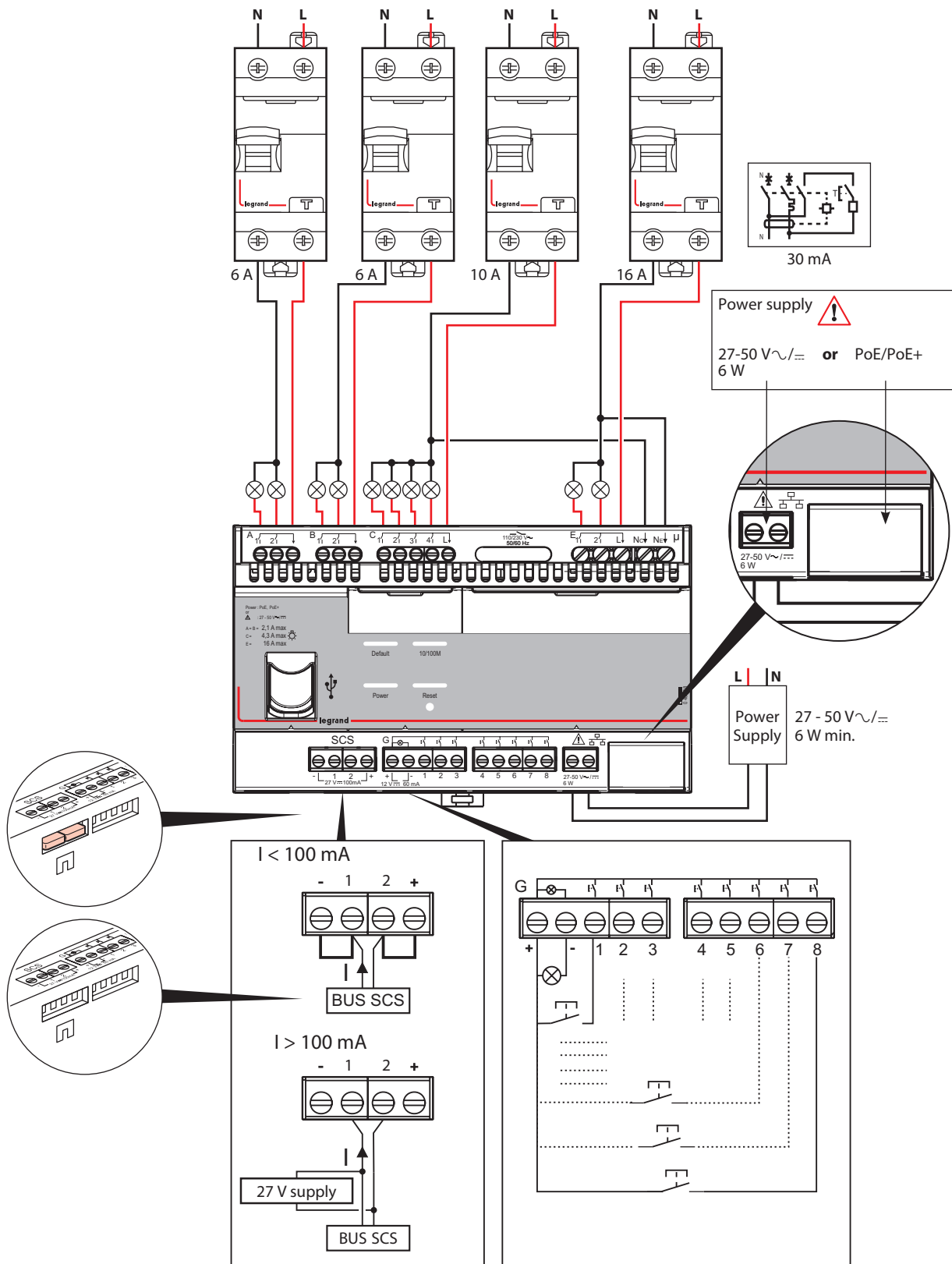

• Single phase (continued)

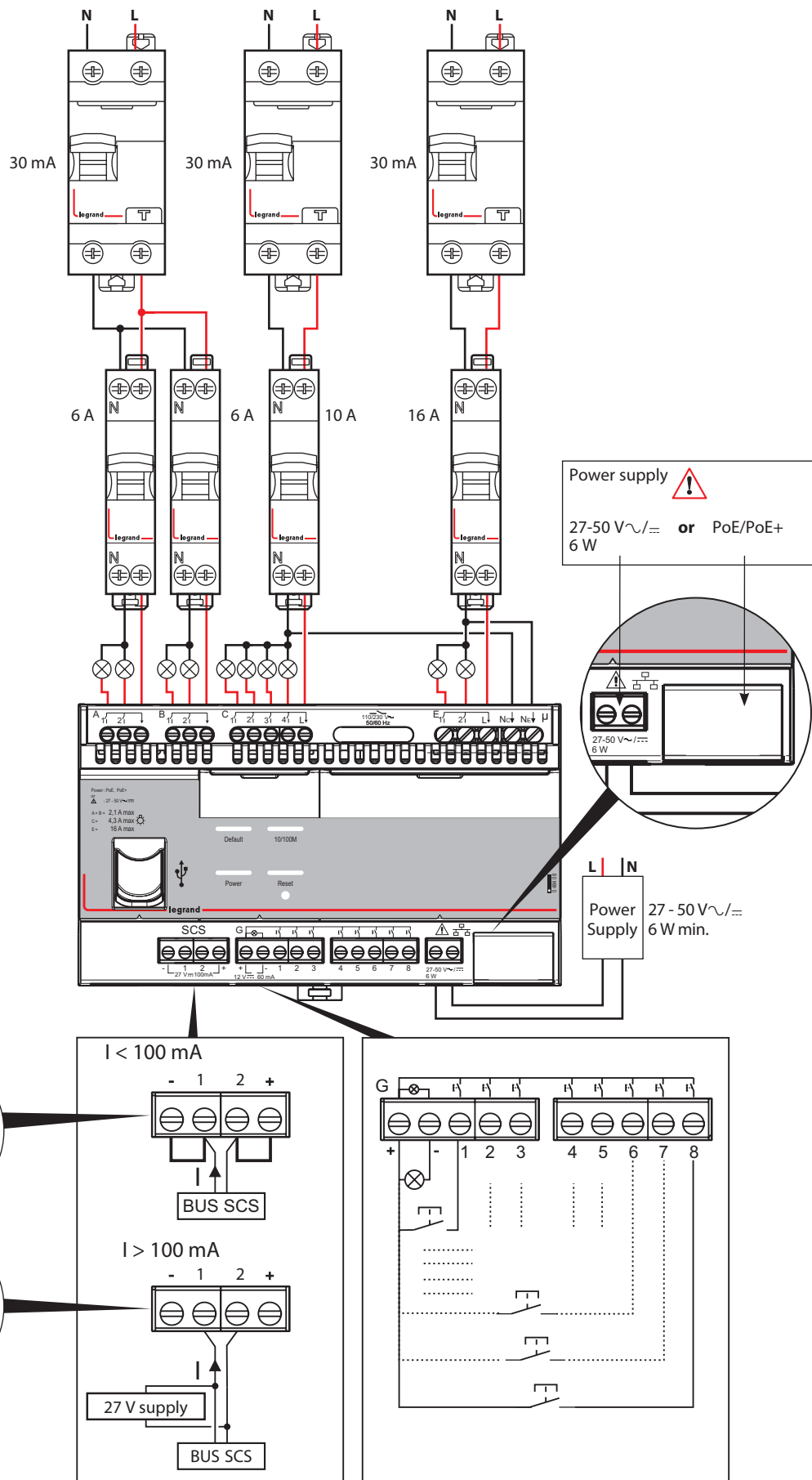

• Three-phase

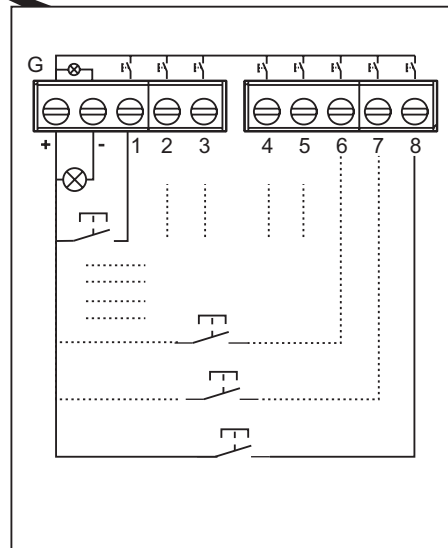
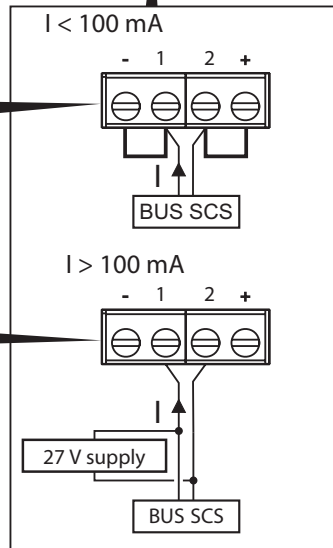
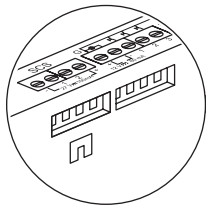
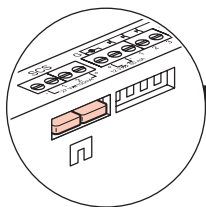
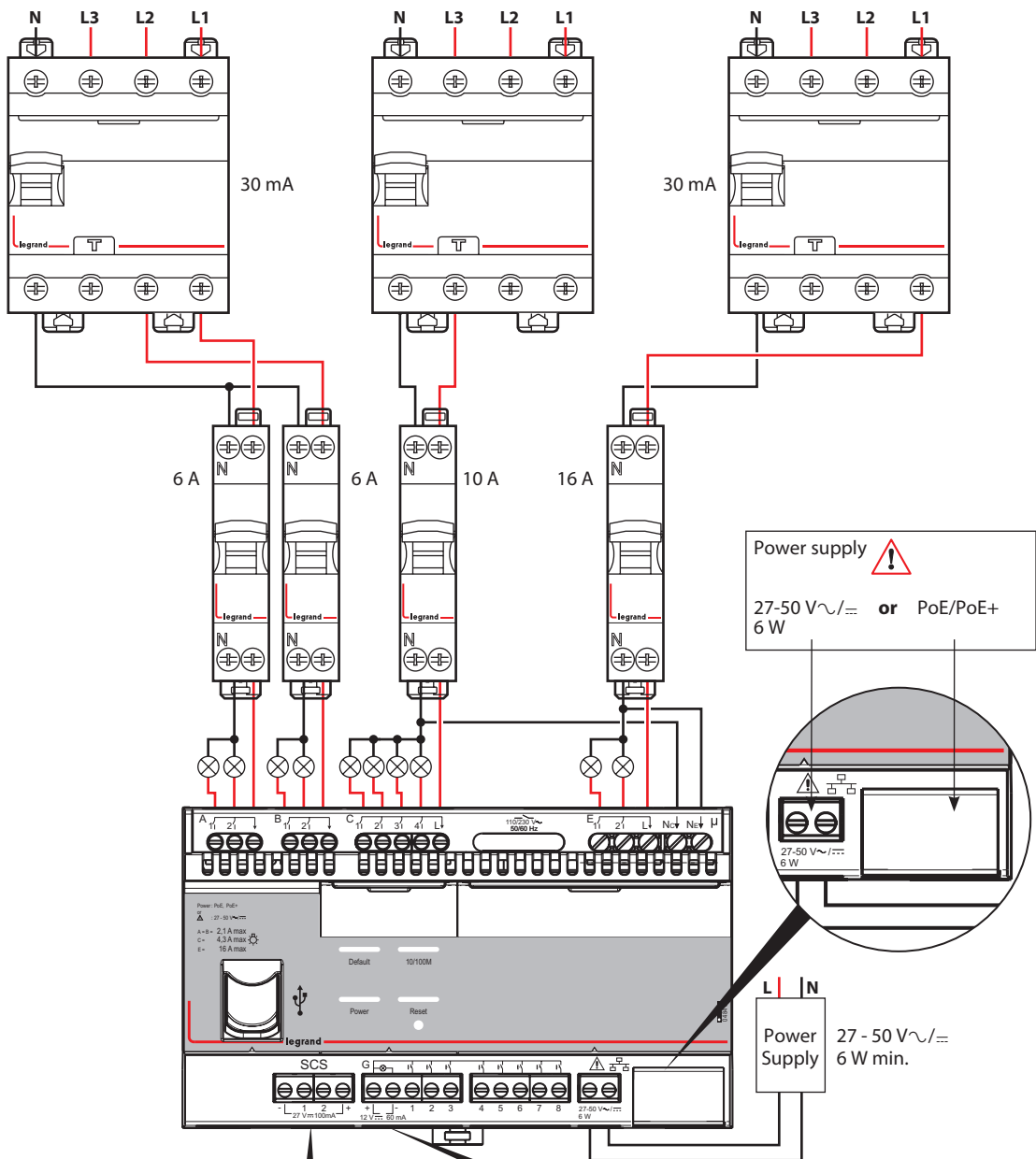

4. Parameter setting

The parameters of the controller are set using a special software tool: HRCS (Hotel Room Controller Software).

 www.legrandoc.com

Factory configuration:

Input	G1	G2	G3	G4	G5	G6	G7	G8
Output	A1/A2	B1/B2	C1	C2	C3	C4	E1	E2
Action	UP/ DOWN	UP/ DOWN	ON/OFF	ON/OFF	ON/OFF	ON/OFF	ON/OFF	ON/OFF

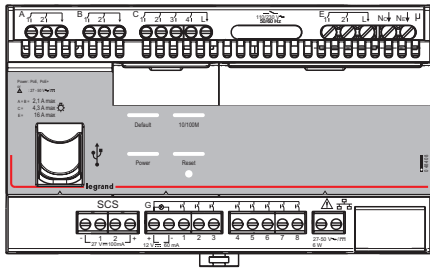

Power LED

- On: the device is powered and has an IP address
- Flashing slowly: the device is powered but does not have a valid IP address
- Off: the device is not powered

When the USB is connected, the LED is on.

10/100 M LED

- Orange LED
 - Off: the cable is not connected
 - On: the cable is connected
 - Flashing: activity indicator
- Green LED
 - Off: 10 Mbps
 - On: 100 Mbps

"Fault" LED

- On: indicates a fault
- Off: no faults

Reset LED

- Flashing slowly: configuration status (following a short press of the Reset button)
- Flashing quickly: reset in progress (following a 10 s press of the Reset button)
- Off: normal operation

Reset button

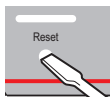

- Short press: the Reset LED flashes slowly and the device sends a BACnet message: "I_AM".

- Long press: the device resets its IP configuration after a short press followed by a long press lasting 10 s

5. Maintenance

Do not use acetone, tar-removing cleaning agents or trichloroethylene.

- Resistant to the following products:
- Hexane
 - Methylated spirit
 - Soapy water
 - Diluted ammonia
 - Bleach diluted to 10%
 - Window-cleaning products

Caution: Before the use of other special maintenance products an initial test is required

6. Standards

CE-compliant

Product standards: IEC 60 669-2-1

Environmental standards:

- European directive 2002/96/EC: WEEE (Waste Electrical and Electronic Equipment)
- European directive 2002/95/EC: RoHS (Restriction of Hazardous Substances)
- Regulations: Public buildings
Workplace buildings
High-rise buildings
- PoE standard: IEEE 802.3 AF/AT