

Product manual | 08.09.2023

ABB-free@home[®] flex

SD/U12.55.1-825 2.4" Display Balance

SD/U12.63.1-825 2.4" (6.10 cm) Display

SD/U12.70.1-4015 ABB SmartTouch[®] 2.4"

RT/U12.86.1-811 4" RoomTouch[®]

RT/U12.86.1-825 ABB RoomTouch[®] 4"



1	Notes on the instruction manual.....	4
2	Safety.....	5
2.1	Information and symbols used.....	5
2.2	Intended use	6
2.3	Improper use	6
2.4	Target group / Qualifications of personnel.....	7
2.4.1	Operation	7
2.4.2	Installation, commissioning and maintenance	7
2.5	Cyber security	8
2.6	Safety instructions.....	10
3	Information on protection of the environment	11
3.1	Environment	11
4	Product Overview	12
4.1	Scope of supply.....	13
4.2	Accessories.....	13
4.3	Overview of types.....	13
4.4	Device overview	14
5	Technical data	15
5.1	Dimensional drawings.....	17
5.2	Circuit diagrams	18
6	Connection, installation / mounting	19
6.1	Planning instructions.....	19
6.2	Safety instructions.....	19
6.3	Requirements for the electrician	19
6.4	Electrical connection	20
6.4.1	Connection.....	20
6.5	Mounting / dismantling.....	21
6.5.1	Installation sites.....	21
6.5.2	Removal protection	22
6.5.3	Mounting	23
6.6	Dismantling.....	25
7	Commissioning via ABB-free@home®	26
7.1	Allocation of devices and definition of channels.....	26
7.1.1	Add device	27
7.2	Setting options per channel	29
7.2.1	Parameter settings	30
7.2.1.1	Parameter settings Channel.....	33
7.2.1.2	Other settings.....	35
7.3	Specifying or editing functions (buttons).....	38
7.3.1	Creating functions	38
7.3.2	Changing functions.....	42

7.3.3	Removing functions.....	43
8	Operation	44
8.1	General control and display functions	44
8.2	Control elements	45
8.2.1	Basic structures of control elements.....	46
8.2.2	Additional basic principles	47
8.2.3	Adjustable control elements	48
8.3	Special functions	54
8.3.1	Return to the previous page	54
8.3.2	Fault and alarm messages	54
8.3.3	Time programs	56
8.4	Inserting the micro SD card (SDHC).....	57
8.5	System settings.....	58
8.5.1	System settings - System information	59
8.5.2	System settings - Firmware update	60
8.5.3	System settings - Reboot	61
8.5.4	System settings - Cleaning blockage	62
8.5.5	System settings - Sensors.....	63
9	Update	64
10	Maintenance	65
10.1	Cleaning	65
11	Notes.....	66
12	Index	67

1 Notes on the instruction manual

Please read through this manual carefully and observe the information it contains. This will assist you in preventing injuries and damage to property and ensure both reliable operation and a long service life for the device.

Please keep this manual in a safe place.

If you pass the device on, also include this manual along with it.

ABB accepts no liability for any failure to observe the instructions in this manual.

If you require additional information or have questions about the device, please contact ABB or visit our Internet site at:

<https://new.abb.com/en>

2 Safety

The device has been constructed according to the latest valid regulations governing technology and is operationally reliable. It has been tested and left the factory in a technically safe and reliable state.

However, residual hazards remain. Read and adhere to the safety instructions to prevent hazards of this kind.

ABB accepts no liability for any failure to observe the safety instructions.

2.1 Information and symbols used

The following Instructions point to particular hazards involved in the use of the device or provide practical instructions:



Danger

Risk of death / serious damage to health

- The respective warning symbol in connection with the signal word "Danger" indicates an imminently threatening danger which leads to death or serious (irreversible) injuries.



Warning

Serious damage to health

- The respective warning symbol in connection with the signal word "Warning" indicates a threatening danger which can lead to death or serious (irreversible) injuries.



Caution

Damage to health

- The respective warning symbol in connection with the signal word "Caution" indicates a danger which can lead to minor (reversible) injuries.



Attention

Damage to property

- This symbol in connection with the signal word "Attention" indicates a situation which could cause damage to the product itself or to objects in its surroundings.



NOTE

This symbol in connection with the word "Note" indicates useful tips and recommendations for the efficient handling of the product.



This symbol alerts to electric voltage.

2.2 Intended use

The displays are multifunctional room control displays for visualizing and operating building functions in ABB i-bus® KNX and ABB-free@home® systems.

The devices are available as frame-based and single displays (ranging from 2.4" to 4.0"). The frame of the design range must be installed with the 2.4" display (e.g. solo, future, axcent, etc.).

The devices are intended for the following:

- Operation according to the listed technical data
- Installation in dry interior rooms
- Use with the connecting options available on the device

The intended use also includes adherence to all specifications in this manual.

2.3 Improper use

Each use not listed in Chapter 2.2 "Intended use" on page 6 is deemed improper use and can lead to personal injury and damage to property.

ABB is not liable for damages caused by use deemed contrary to the intended use of the device. The associated risk is borne exclusively by the user/operator.

The device is not intended for the following:

- Unauthorized structural changes
- Repairs
- Outdoor use
- The use in bathroom areas
- Insert with an additional bus coupler

2.4 Target group / Qualifications of personnel

2.4.1 Operation

No special qualifications are needed to operate the device.

2.4.2 Installation, commissioning and maintenance

Installation, commissioning and maintenance of the device must only be carried out by trained and properly qualified electrical installers.

The electrical installer must have read and understood the manual and follow the instructions provided.

The electrical installer must adhere to the valid national regulations in his/her country governing the installation, functional test, repair and maintenance of electrical products.

The electrical installer must be familiar with and correctly apply the "five safety rules" (DIN VDE 0105, EN 50110):

1. Disconnect
2. Secure against being re-connected
3. Ensure there is no voltage
4. Connect to earth and short-circuit
5. Cover or barricade adjacent live parts

2.5 Cyber security

The industry faces intensifying cyber security risks. In order to increase stability, safety and robustness of its solutions, ABB has formally established cyber security robustness testing as part of the product development process.

The following measures are prerequisite for the safe operation of your system. ABB accepts no liability for non-observance.

Access control and limitation

The careful isolation of the system against unauthorized access is the basis for every protective concept. Only authorized persons (fitter, caretaker, tenant) are allowed physical access to the IP network or bus system and its components. This also includes the device described in this instruction manual.

The best possible protection of the IP or network media (WLAN) and the transfer nodes must be guaranteed already during planning and installation. Sub-distributions with fieldbus devices must be lockable or be in rooms to which only authorized persons have access.

Bus cabling

- The ends of the bus cables must not be visible, i.e. they must not project out of walls or channels, either inside or outside of the building.
- Bus cables in outdoor areas or in areas with limited protection represent an increased safety risk. The physical access should be made exceptionally difficult.

IP Network

The local network represents a sensitive component for safe communication. That is why unauthorized access to the local network should be prevented. The normal safety mechanisms for IP networks are to be used, e.g.:

- Safe encryption of wireless networks
- Use of complex passwords and protection of these against unauthorized persons
- Physical access to network interfaces (Ethernet interfaces) and network components (router, switches) should only be possible in protected areas.
- MAC filter (table with certified device addresses)

Connection to the Internet or the local IP network

To prevent improper use, no router ports from the Internet into the building network or home network are to be opened to the display. A VPN tunnel is suitable for safe remote control.

The stable and reliable function of the device also depends on the reliability of the local IP network to which the server is connected. For this reason additional network components are to be used to repel the DoS attacks (denial of service) from the Internet. Such attacks can overload the local IP network or the individual components and make them inaccessible.

Safety of user accounts

Set a strong access password during initial commissioning. Use passwords that you have received from the administrator only for the first login.

Keep passwords secret and use a password manager with two-factor login as memory aid, e.g. Keepass.

Updates

The device supports various update options. A detailed overview is available in Chapter 8.5.2 "System settings - Firmware update" on page 60.

Backup / Restoration

The user can backup / restore device settings. To perform the backup the user must enter a password. This password is used as safety key to encrypt the backup information. If the user wants to restore the device settings via a backup file, he must first enter the defined password so that the backup information can be decrypted.

Solutions for protection against malware

The product is not susceptible to malware, because a user-defined code cannot be executed on the system. The only option of updating the software is the update of the firmware. Only a firmware signed by ABB is accepted.

Password rules

Preset passwords should be changed by the user during the first use of the device.

2.6 Safety instructions



Danger - Electric voltage!

Electric voltage! Risk of death and fire due to electric voltage of 100 ... 240 V. Dangerous currents flow through the body when coming into direct or indirect contact with live components. This can result in electric shock, burns or even death.

- Work on the 100 ... 240 V supply system may only be performed by authorised and qualified electricians.
- Disconnect the mains power supply before installation / disassembly.
- Never use the device with damaged connecting cables.
- Do not open covers firmly bolted to the housing of the device.
- Use the device only in a technically faultless state.
- Do not make changes to or perform repairs on the device, on its components or its accessories.
- Keep the device away from water and wet surroundings.



Caution! - Risk of damaging the device due to external factors!

Moisture and contamination can damage the device.

- Protect the device against humidity, dirt and damage during transport, storage and operation.

3 Information on protection of the environment

3.1 Environment



Consider the protection of the environment!

Used electric and electronic devices must not be disposed of with domestic waste.

- The device contains valuable raw materials which can be recycled. Therefore, dispose of the device at the appropriate collecting depot.

All packaging materials and devices bear the markings and test seals for proper disposal. Always dispose of the packaging material and electric devices and their components via the authorized collecting depots and disposal companies.

The products meet the legal requirements, in particular the laws governing electronic and electrical devices and the REACH ordinance.

(EU Directive 2012/19/EU WEEE and 2011/65/EU RoHS)

(EU REACH ordinance and law for the implementation of the ordinance (EC) No.1907/2006).

4 Product Overview



Fig. 1: Product overview

The displays are multifunctional room control displays for visualizing and operating building functions in ABB i-bus® KNX and ABB-free@home® systems.

- The devices are available in frame-bound form and single displays (2.4" and 4.0").
- The displays have a capacitive touchdisplay with a resolution of 240 x 240 points.
- The control is connected with a haptic feedback (vibration) and signals specific operating statuses to the user.
- Up to 4 functions per page, up to a total of 12 functions on several pages.
- The 2.4" displays can be combined with existing design lines (e.g. solo, future, accent, etc.).

The displays are compatible with both bus systems of ABB i-bus® KNX and free@home Bus. The signals are transmitted and the power for the device is supplied via the ABB i-bus® KNX or the free@home Bus. An additional power supply is required.

The device can also be used for the display of fault and alarm messages.

Configuration of free@home

Commissioning for free@home Twisted Pair is made via the free@home System Access Point.

4.1 Scope of supply

- Display
- 2 Connecting terminals
- Support ring



Notice

- The connection with the ABB i-bus® KNX is established by means of the enclosed bus connection terminal.
- The connection of the necessary auxiliary power supply and optional temperature sensors is made via an enclosed connecting terminal.
- The connections of the power supply and the temperature sensor must not be switched. Otherwise the device will be damaged.

4.2 Accessories

Not included in the scope of delivery, please order separately

- Power supply via a separate power adaptor, e.g. CP-D 24/2.5
- Temperature sensor Pt1000 or DP4-T-1

4.3 Overview of types

Article no.	Product name	Colour	Dimension	Display diagonal
SD/U12.55.1-825	2.4" Display Balance	Black	55 mm x 55 mm	6.1 cm (2.4")
SD/U12.63.1-825	2.4" (6.10 cm) Display	Black	63 mm x 63 mm	6.1 cm (2.4")
SD/U12.70.1-4015	ABB SmartTouch® 2.4"	Black	70 mm x 70 mm	6.1 cm (2.4")
RT/U12.86.1-811	4" RoomTouch®	Black	86 mm x 86 mm	10.16 cm (4")
RT/U12.86.1-825	ABB RoomTouch® 4"	White	86 mm x 86 mm	10.16 cm (4")

Table 1: Overview of types

4.4 Device overview

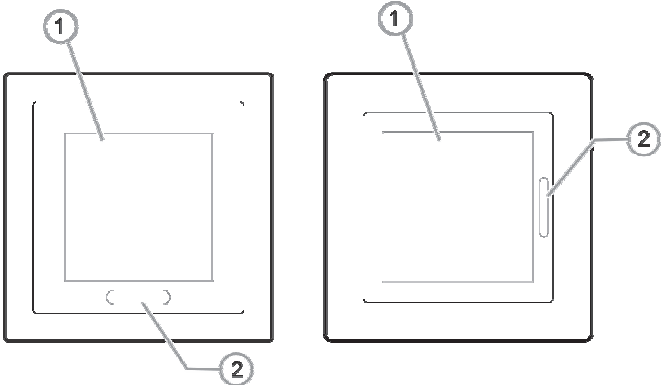

Fig. 2: Device overview of 2.4" display front side

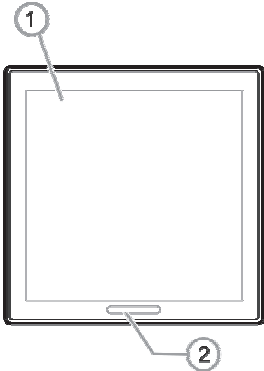

Fig. 3: Device overview of 4" display front side

Pos.	Description
1	Touch screen
2	Proximity and brightness sensor

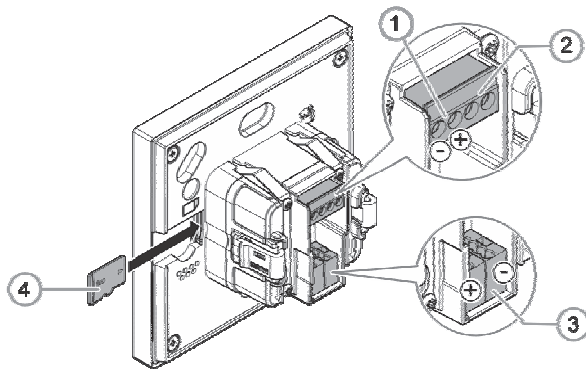

Fig. 4: Device overview of display rear side

Pos.	Description
1	Connection of auxiliary power supply
2	Temperature sensor connection
3	Bus connection
4	SD card insertion position

5 Technical data

Designation	Value
Display resolution:	240 x 240 pixel (HD)
Aspect ratio:	1:1
Colour resolution:	16 million colours
Display size:	6.10 cm (2.4") 10.16 cm (4")
Viewing angle:	
– Horizontal	75°
– Vertical	75°
Background illumination	LED
Maximum brightness:	±240 cd/m ²
Service life:	±20 000 h (at maximum brightness of > 125cd/m ²)
Touch technology:	Capacitive
– Calibration	Automatic
Bus voltage:	
▪ ABB i-bus® KNX	21 V - 32 V DC
▪ ABB-free@home®	
Bus participants:	1 (7.5 mA)
Power supply (SELV): (e.g. MDRC power adapter CP-D 24/2.5)	20 - 32 V DC

Nominal current:	24 V DC, 75 mA for 2.4" 24 V DC, 100 mA for 4"
Bus and power supply connection Bus connection terminal Line type: Wire stripping:	0.6 - 0.8 mm J-Y(St)Y, 2 x 2 x 0.8 mm 5 - 6 mm
Transmission protocol:	KNX (TP, S) ABB-free@home® (TP)
micro SD card reader File System:	microSD, microSDHC, microSDXC (SD card not included in delivery) FAT32
Internal temperature sensor:	Yes
External temperature sensor:	Pt1000 or DP4-T-1 (not included in the scope of delivery)
Protection type:	IP20
Operating temperature:	-5°C - +45°C
Storage temperature:	-20°C - +70°C
Dimensions:	See Chapter 5.1 "Dimensional drawings" on page 17
Startup: – Parameter setting (KNX) – Programming	ETS 5.7.7 or ETS 6 or web-interface System Access Point via KNX bus or micro SD card

Table 2: Technical data

5.1 Dimensional drawings



Notice

All dimensions are in millimetres.

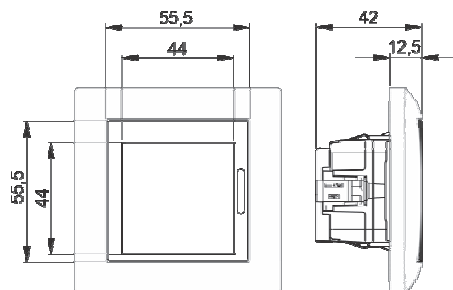

Fig. 5: 2.4" Display Balance SD/U12.55.1-825

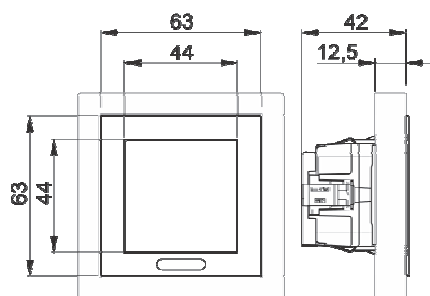

Fig. 6: 2.4" (6.10 cm) Display SD/U12.63.1-825

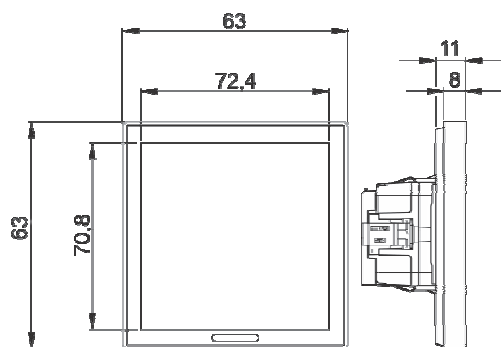

Fig. 7: 4" RoomTouch® RT/U12.86.1-811

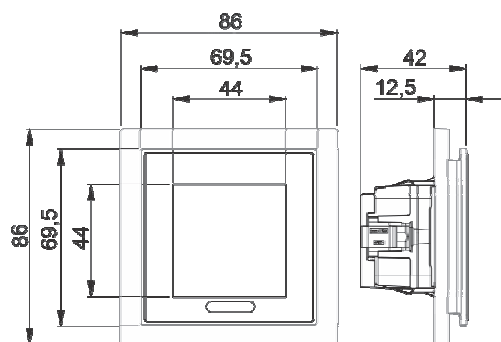

Fig. 8: ABB SmartTouch® 2.4" SD/U12.70.1-4015

5.2 Circuit diagrams



Attention! - Risk of damaging the device

- Observe the correct polarity!
- The power input connector [1] and the temperature sensor/binary input connector [2] must under no circumstances be mismatched. Otherwise, the device may be damaged.
- Apply only passive signals without own power supply to temperature sensor/binary input socket [2].

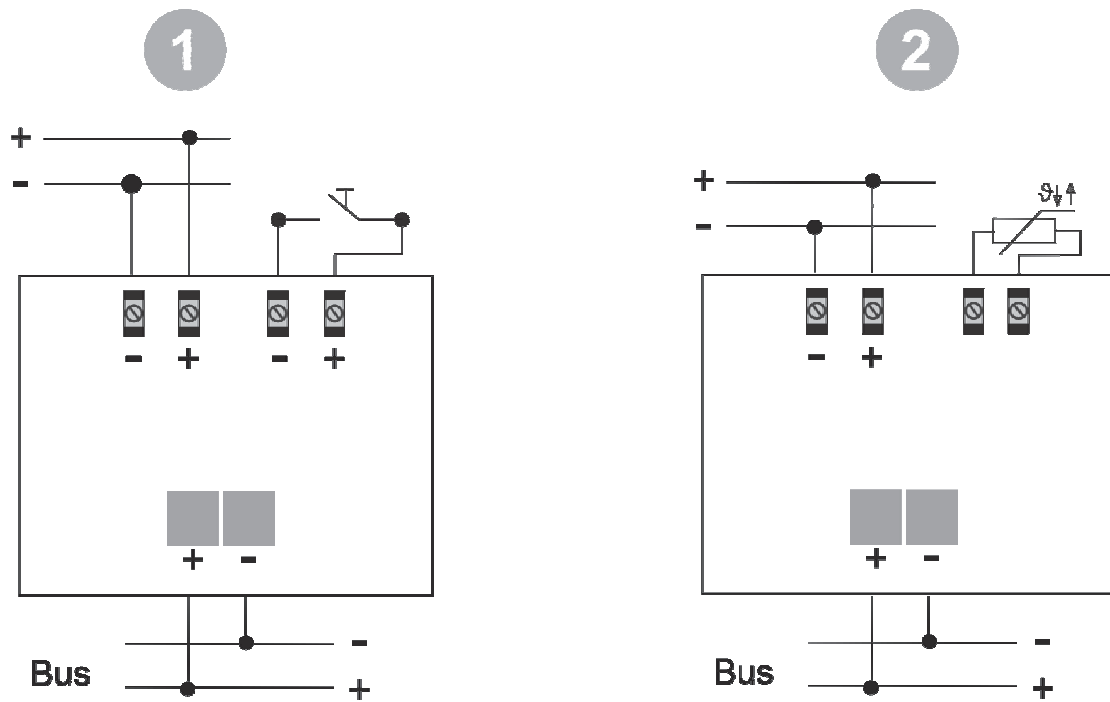

Fig. 9: Electrical connection

No.	Function
1	Connection with external binary input
2	Connection with room temperature sensor

Table 3: Electrical connection

6 Connection, installation / mounting

6.1 Planning instructions



Notice

Planning and application instructions for the system are available in the system manuals for ABB i-bus® KNX and ABB-free@home®. These can be downloaded via <https://new.abb.com/en> or <https://abb.com/freeathome>.

6.2 Safety instructions



Danger - Electric shock due to short-circuit!

Risk of death due to electrical voltage of 100 to 240 V during short-circuit in the low-voltage line.

- Low-voltage and 100 - 240 V lines must not be installed together in a flush-mounted box!
- Observe the spatial division during installation (> 10 mm) of SELV electric circuits to other electric circuits.
- If the minimum distance is insufficient, use electronic boxes and insulating tubes.
- Observe the correct polarity.
- Observe the relevant standards.

6.3 Requirements for the electrician



Danger - Electric voltage!

Install the device only if you have the necessary electrical engineering knowledge and experience.

- Incorrect installation endangers your life and that of the user of the electrical system.
- Incorrect installation can cause serious damage to property, e.g. due to fire.

The minimum necessary expert knowledge and requirements for the installation are as follows:

- Apply the "five safety rules" (DIN VDE 0105, EN 50110):
 1. Disconnect
 2. Secure against being re-connected
 3. Ensure there is no voltage
 4. Connect to earth and short-circuit
 5. Cover or barricade adjacent live parts.
- Use suitable personal protective clothing.
- Use only suitable tools and measuring devices.
- Check the type of supply network (TN system, IT system, TT system) to secure the following power supply conditions (classic connection to ground, protective earthing, necessary additional measures, etc.).

6.4 Electrical connection

6.4.1 Connection



Attention! - Risk of damaging the device

Observe the floating isolation of the control and working power circuit. Non-observance can cause damage to the device.



Attention! - Risk of damaging the device

- Observe the correct polarity!
- The power input connector [1] and the temperature sensor/binary input connector [2] must under no circumstances be mismatched. Otherwise, the device may be damaged.
- Apply only passive signals without own power supply to temperature sensor/binary input socket [2].

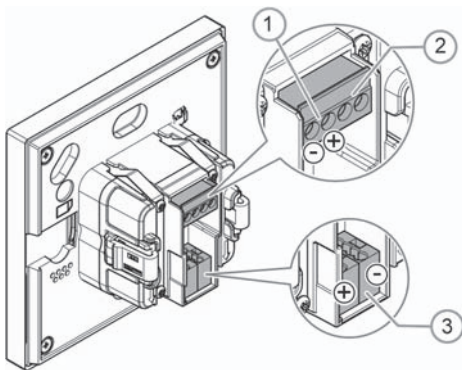

Fig. 10: Function of connection

No.	Function
1	Power supply connection
2	Temperature sensor/binary input connection
3	KNX bus connection

Table 4: Function of connection

1. Connecting the device see chapter 5.2 “Circuit diagrams“ on page 18.

6.5 Mounting / dismantling

6.5.1 Installation sites

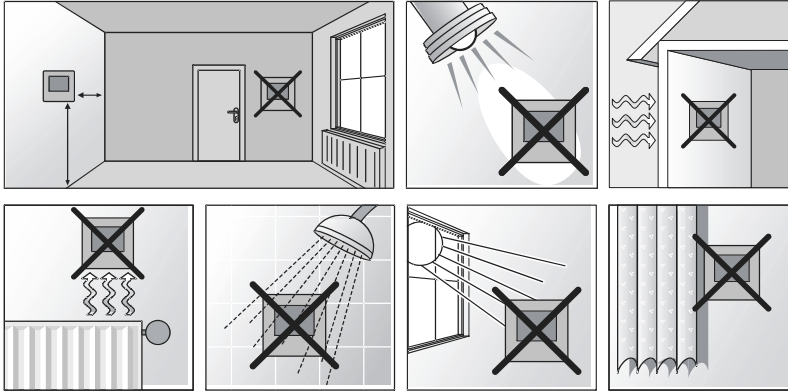

Fig. 11: Installation sites

- When selecting the installation location, ensure that there is a distance to sources of heat or cold.
- Heat or cold sources influence the function of the internal temperature sensor.
- The device should be mounted on a wall opposite the heat source. The distance to side walls or door frames should be at least 50 cm. The distance to the floor should be about 150 cm.
- Do not mount the device on an exterior wall. Low outside temperatures have an effect on the temperature regulation.
- The device must not come into direct contact with liquids.
- Do not mount the device in direct sunlight, near radiators, windows, light sources or behind curtains.

Mounting height

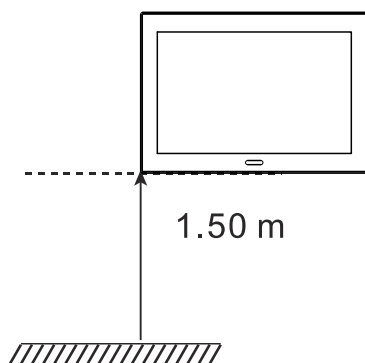

Fig. 12: Mounting height

- The mounting height is 1.50 m.

6.5.2 Removal protection

Removal protection (optional)



Notice

The removal protection TZE/U.0.1.CK is available as an option.

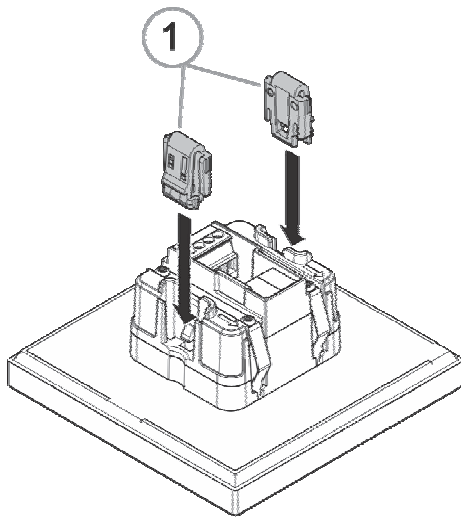

Fig. 13: Installation of the removal protection

For removal protection, the clamps [1] must be inserted before installation.

6.5.3 Mounting

Fig. : Mounting with cover frame

Mounting with cover frame is possible with the following displays:

- SD/U12.55.1-825 2.4" Display Balance
- SD/U12.63.1-825 2.4" (6.10 cm) Display
- SD/U12.70.1-4015 ABB SmartTouch® 2.4"

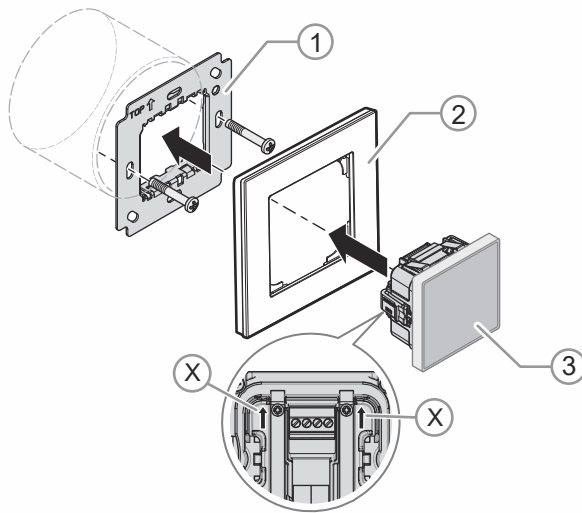

Fig. 14: Mounting with cover frame

For mounting with cover frame the following steps are necessary:

1. Install the support ring [1] .
2. Insert the device in the cover frame [2].
3. Connect the wires to the connecting terminals, see chapter 6.4 “Electrical connection“ on page 20.
4. Snap the device [3] into the support ring [1] by hand.
 - Observe the correct alignment [X]!



Notice

The arrows [X] on the back must point upwards.

The device is now fully mounted.

Mounting without cover frame

Mounting without cover frame is possible with the following displays:

- RT/U12.86.1-811 4" RoomTouch®
- RT/U12.86.1-825 ABB RoomTouch® 4"

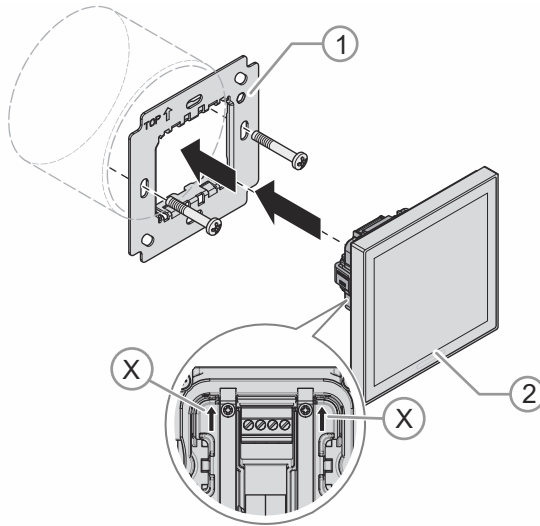

For mounting without cover frame the following steps are necessary:

1. Install the support ring [1] .
2. Connect the wires to the connecting terminals, see chapter 6.4 “Electrical connection“ on page 20.
3. Snap the device [2] into the support ring [1] by hand.
 - Observe the correct alignment [X]!



Notice

The arrows [X] on the back must point upwards.

The device is now fully mounted.

6.6 Dismantling

Dismantling is carried out in the reverse order to mounting.



Notice

After mounting with Removal protection for control elements, (see chapter 6.5.3 “Mounting” on page 23), removal protection, dismantling is then only possible with Removal protection tool TZW/U.0.1.CK!

For dismantling with Removal protection for control elements, carry out the following steps:

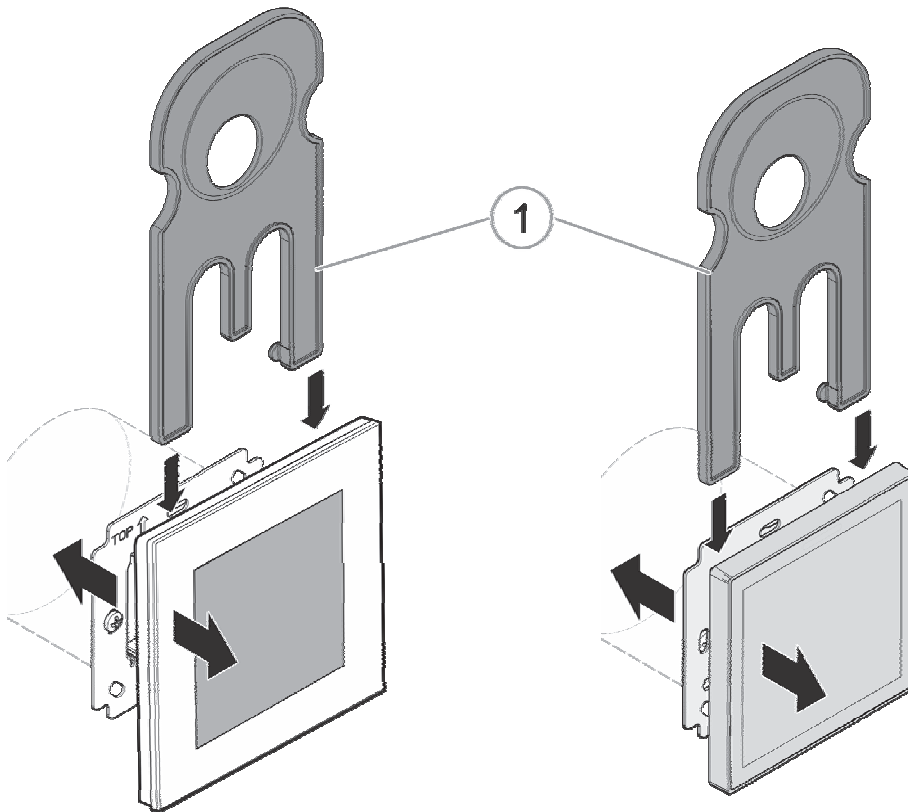

Fig. 15: Dismantling with removal tool

1. Guide the Removal protection tool tool down behind the device to the limit stop.
2. Remove the device.

7 Commissioning via ABB-free@home®

Commissioning of the device is always carried out via the web-based surface of the System Access Point. It is assumed that the basic commissioning steps of the overall system have already been carried out. Knowledge about the basic functions of the commissioning software of the System Access Point is assumed.

The System Access Point establishes the connection between the free@home Bus participants and the smartphone, tablet or PC. The System Access Point is used to identify and program the participants during commissioning. The link of the display with the System Access Point is made during the course of initial commissioning.

The devices can be parameterised for the use of additional functions.



Notice

General information about commissioning and parameterization is available in the ABB-free@home® system manual.

7.1 Allocation of devices and definition of channels

The devices integrated into the system must be identified, i.e. they are allocated to a room according to their function and are given a name.

The allocation is carried out via the web-based user interface of the System Access Point or the ABB-free@home® App Next.

7.1.1 Add device

1. Tap on the switch icon (menu devices, scenes and groups) at the left edge of the screen.
 - The "Building plan" opens.
2. Tap on the round plus icon at the bottom right [1].
 - Menu "Select component" opens.



Fig. 16: Opening the building plan and list of components (example illustration)

3. Tap on the desired characteristic in the list of components.
 - The menu with the available devices, functions and actuators opens.
4. Select the desired device and pull it into the floor plan via drag-and-drop.

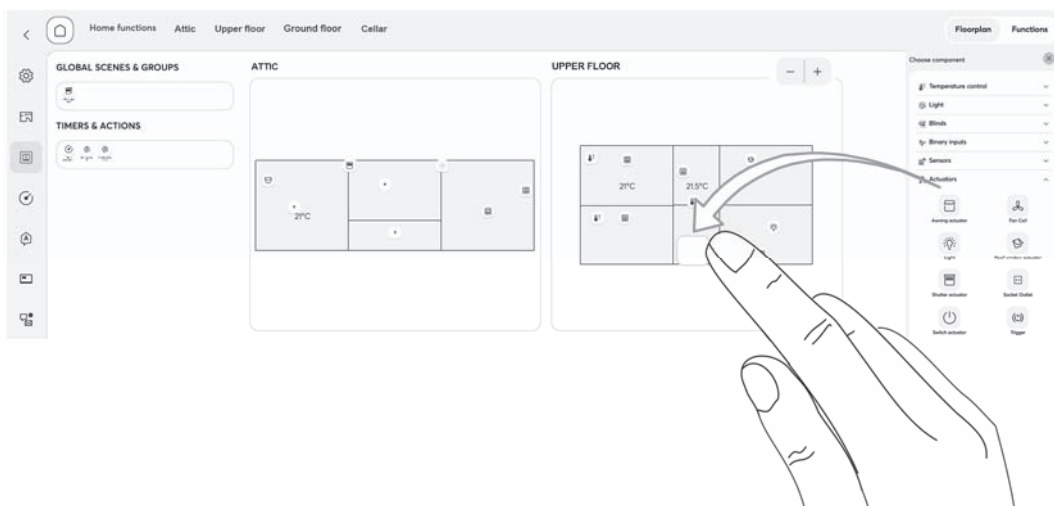

Fig. 17: Pulling the device out of the menu bar (example illustration)

If you pull a new device into a room via drag-and-drop, a pop-up window opens in which all devices that are located in the system are listed and which have not been allocated to a room. The devices are suitable respectively for the selected application.

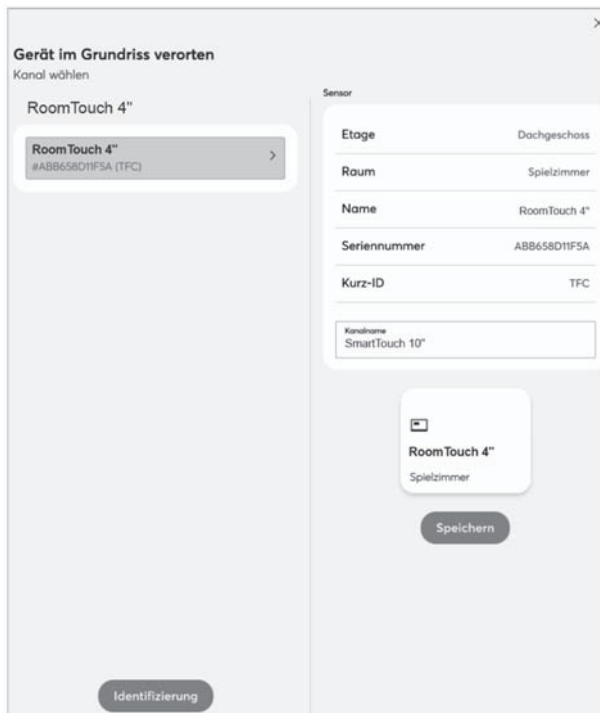

Fig. 18: Pop-up window with the suitable devices (example illustration)

Identification

The device can be identified via the serial number.

Identification via serial number

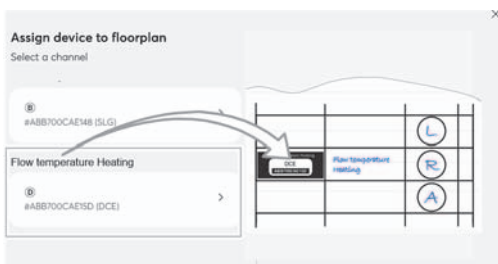

Fig. 19: Identification via serial number (example illustration)

- Compare the serial number and the short ID of the identification label, which is glued on the device plan, with the numbers and IDs in the list. This is how the searched for device and possibly the searched for channel are identified.

Specifying a name

1. Enter a name in text field under which the application is to be displayed later, e.g. "Ceiling light" or "Living room blind".
2. Tap the "Save" button to take over the adjustments.
 - This takes over the entry.

7.2 Setting options per channel

General settings and special parameter settings can be made for each channel.

The settings are made via the web-based user interface of the System Access Point.

Select device

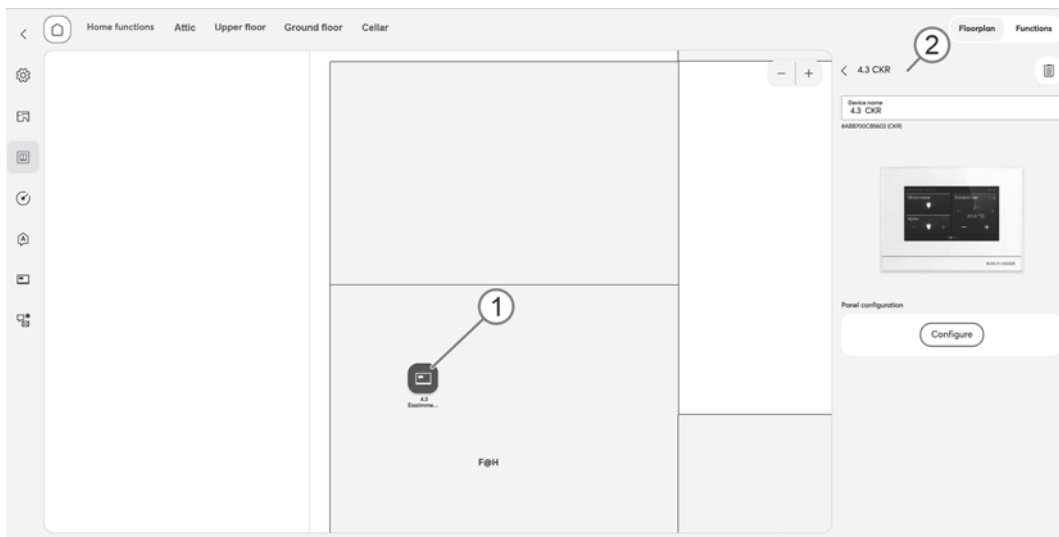

Fig. 20: Selecting device

1. Select the device icon [1] in the floor plan of the working area view.
 - The setting options (name, linkage to display configuration) for the respective display are shown in the list view [2].

7.2.1 Parameter settings

Open overview of devices

1. In the main menu select "Devices, scenes & groups" (toothed-wheel icon) [1].
If you do not enter via the main menu, click on the icon [2].

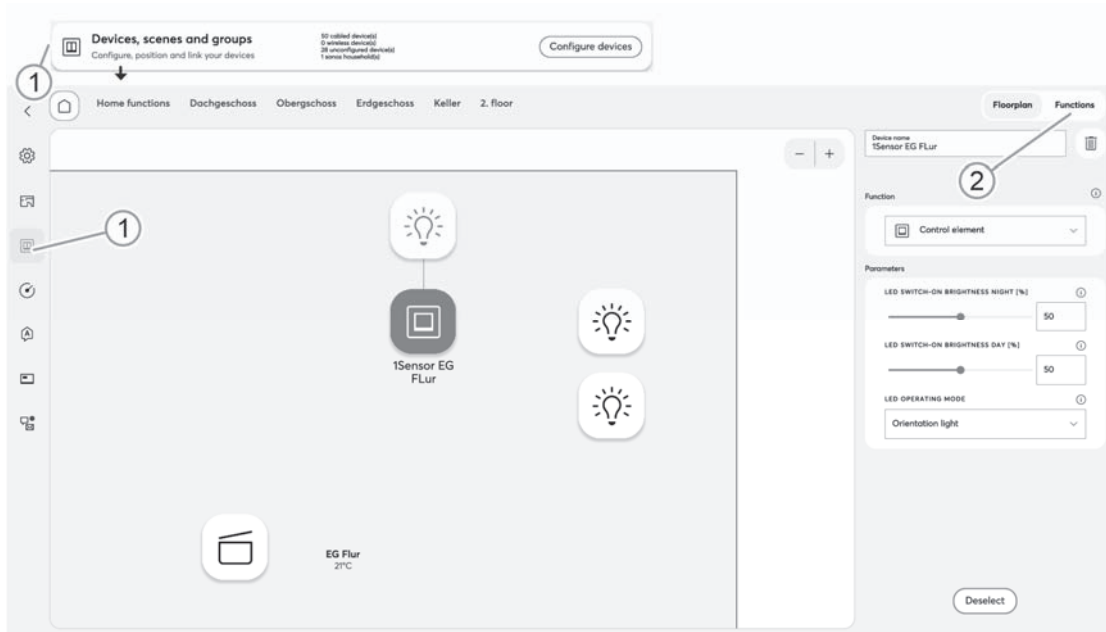

Fig. 21: Open overview of devices (example illustration)

2. Select the "Functions" button [3].
 - The overview of devices opens.
 - Here you can view all devices that are located in the free@home system. The overview page displays information about the device name and the position of the respective device.

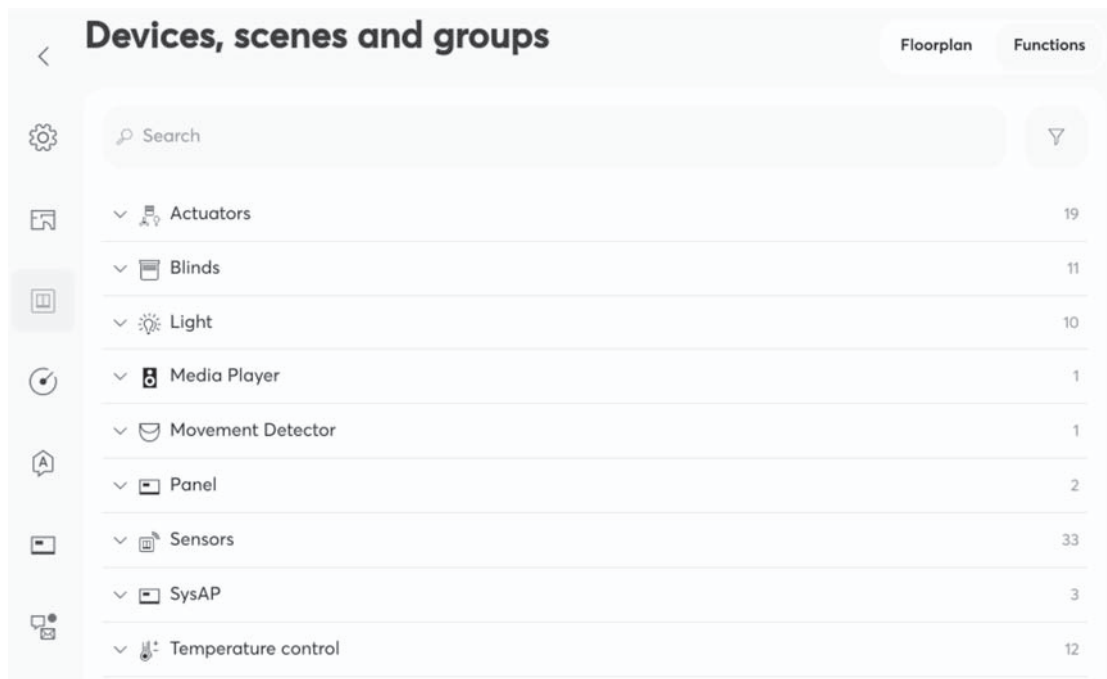

Fig. 22: Overview of devices (example illustration)

3. Tap on a device category.
 - The list of available devices opens.
4. Tap on the device whose information you want to edit.
 - A new window with information about the respective device opens.

Information about the device name, the device position in the building and additional settings are illustrated in the device menu.

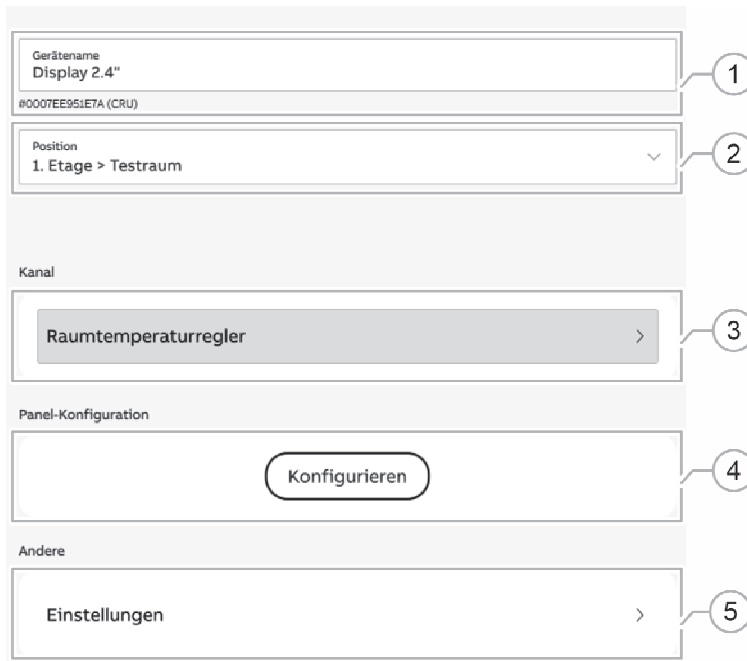

Fig. 23: Device menu

Pos.	Description
[1]	Device name An independent designation for the device can be allocated via the text field.
[2]	Position By tapping on the drop-down menu you can assign a position to the device in the building structure you defined (e.g. assignment to a room on a certain floor).
[3]	Channel Here you reach the parameter settings of the channel. <ul style="list-style-type: none"> ▪ Channel <ul style="list-style-type: none"> – Opens the parameter setting of the channels for the internal room temperature controller.
[4]	Panel configuration The button is used to access the panel configuration. Here you can add additional control elements to the panel interface. For details about the panel configuration, See “Specifying or editing functions (buttons)” on page 38.
[5]	Other settings Here you access the settings for channel selection, authorizations and maintenance. You can also view the general device information.

7.2.1.1 Parameter settings Channel

The screenshot shows the 'Parameter settings Channel' interface with the following elements and callouts:

- 1**: Kanalname (Channel name) text field containing 'Raumtemperaturregler'.
- 2**: Position dropdown menu showing 'Erdgeschoss > EG Flur'.
- 3**: Room temperature sensor control area showing '21°C', a plus/minus icon, and a button.
- 4**: Zeitschaltprogramme (Time switch programs) section showing 'Grundprofil (0)' with a checkmark.
- 5**: Berechtigungen (Permissions) section with a right-pointing arrow.
- 6**: Parameter section containing:
 - ECO TEMPERATURABSENKUNG [°C]: Input field with value 3,0.
 - TEMPERATURKORREKTUR [°C]: Input field with value 0,0.
 - NACHLAUFZEIT BEI ABWESENHEIT [S]: Slider control with value 1.800.
 - VERWENDUNG INTERNER / EXTERNER TEMPERATURERFASSUNG: Dropdown menu with 'intern zur Regelung' selected.
 - TEMPERATURKORREKTUR EXTERNER SENSOR [°C]: Input field with value 0,0.
 - TEMPERATUROBERGRENZE [°C]: Input field with value 50,0.

Fig. 24: Parameters of channel

Under the channel settings you can configure the settings described in the following.

Pos.	Description
[1]	Device name An independent designation for the device can be allocated via the text field.
[2]	Position By tapping on the drop-down menu you can assign a position to the device in the building structure you defined (e.g. assignment to a room on a certain floor).
[3]	Room temperature sensor The internal room temperature controller can be set by tapping on the button. You can switch it on and off, set the actual temperature and specify the operating mode.
[4]	Time programs This overview displays all previously created time programs. The number after a time program indicates how often the actuator is used in this time profile. Select a time program for adding it to the actuator.

[5]	<p>Authorizations</p> <p>Menu item "Authorizations" is used to specify whether a user with installer authorization is required for the reconfiguration of the actuator.</p> <p>In addition, you can nevertheless assign users with read rights the authorization to switch this actuator.</p>	
[6]	<p>Parameters</p>	
	<p>Eco temperature reduction [°C]</p>	<p>The -/+ buttons can be used to specify by how many degrees the temperature is to be reduced to when ECO mode is activated.</p>
	<p>Temperature correction [°C]</p>	<p>Manual increase/reduction of the temperature value via the -/+ buttons to adjust a permanent temperature offset.</p>
	<p>Switch-off delay during absence [s]</p>	<p>If the ECO mode is deactivated by a movement detector, the switch-off delay can be specified here when the ECO mode is to be re-activated after the room is exited.</p>
	<p>Use of internal/external temperature reading</p>	<p>The following selection options are available for the temperature reading.</p> <ul style="list-style-type: none"> ▪ Internal for regulating: <ul style="list-style-type: none"> – Use of the internal temperature sensor of the device for reading and regulating the room temperature. ▪ External for regulating: <ul style="list-style-type: none"> – Use of an external temperature sensor for reading and regulating the floor temperature. For this the external temperature sensor must be laid in the screed. ▪ Internal and external for regulating: <ul style="list-style-type: none"> – Use of the internal and an external temperature sensor for reading and regulating the room temperature. Both measured values are used to create an average value. For this the external temperature sensor must be installed behind a ventilated cover plate (e.g. 6541-xx). ▪ Internal for regulating and external for limiting: <ul style="list-style-type: none"> – Use of the internal and an external temperature sensor for reading temperature. The temperature is regulated via the internal temperature sensor. The external temperature sensor serves for limiting the temperature, generally the floor temperature (floor heating). As soon as the temperature measured on the external temperature sensor exceeds the set temperature, the relay is switched off. Heating stops.
<p>Temperature correction of external sensor [°C]</p>	<p>Manual increase/reduction of the temperature value of the external sensor, to adjust a permanent temperature offset.</p>	
<p>Upper temperature limit [°C]</p>	<p>Fixing the maximum admissible temperature that is allowed to be measured by the external temperature sensor before the relay for the heating is switched off. The upper temperature limit is used, for example, to ensure that the floor temperature does not get too warm and cause damage to the floor covering.</p>	

7.2.1.2 Other settings

HELLIGKEIT WIRD AN DAS UMGEBUNGSLICHT ANGEPASST

Nein

LED-EINSCHALTHELLIGKEIT NACHT [%]

50

LED-EINSCHALTHELLIGKEIT TAG [%]

50

ÜBER DEN NÄHERUNGSSENSOR DAS DISPLAY UMSCHALTEN

Ja

EMPFINDLICHKEIT NÄHERUNGSSENSOR

3

HAPTISCHES FEEDBACK

Ja

EINFACHE ANSICHT

Ja

AUTOMATISCHE RÜCKKEHR ZUR STARTSEITE AKTIVIEREN

Nein

AUTOMATISCHE RÜCKKEHR ZUR STARTSEITE [S]

60

BILDSCHIRMSCHONERMODUS

Uhr

BILDSCHIRMSCHONER

10 Min.

DISPLAY RUHEZUSTAND

30 Min.

IN MASSIVWAND EINGEBAUT

Ja

Abb. 25: Other settings - Part 1



Abb. 26: Other settings - Part 2

Under "Other settings" you can configure the settings described in the following.

Pos.	Description																								
	Parameters																								
	<table border="1"> <tr> <td>Adjusting the brightness to the ambient lighting</td> <td>By activating or deactivating the parameter, the automatic adjustment of the display brightness to the ambient brightness is activated.</td> </tr> <tr> <td>LED switch-on brightness night [%]</td> <td>Setting the LED switch-on brightness for night in % via the -/+ buttons. Notice: The parameter only functions when a time profile with the application "LED day/night switchover" is available. The device (channel) must be linked with this application!</td> </tr> <tr> <td>LED switch-on brightness day [%]</td> <td>Setting the LED switch-on brightness for day in % via the -/+ buttons. Notice: The parameter only functions when a time profile with the application "LED day/night switchover" is available. The device (channel) must be linked with this application!</td> </tr> <tr> <td>Switchover of display via the proximity sensor</td> <td>Specifying whether the proximity sensor is to be used for switching the display.</td> </tr> <tr> <td>Proximity sensor sensitivity</td> <td>The parameter is used to specify the sensitivity of proximity sensor.</td> </tr> <tr> <td>Haptic feedback</td> <td>The parameter is used to specify whether a haptic feedback is to take place.</td> </tr> <tr> <td>Simple view</td> <td>This parameter is used to deactivate or activate the simple view. In this view the information is illustrated in reduced form. The extended view offers additional setting options and information.</td> </tr> <tr> <td>Activating automatic return to the start page [s]</td> <td>This parameter is used to set the number of seconds after which the display view changes automatically to the start page.</td> </tr> <tr> <td>Screensaver mode</td> <td>Specifying the form in which the screen saver is to be displayed.</td> </tr> <tr> <td>Screensaver</td> <td>Specifying the time at which the screen saver is to be activated.</td> </tr> <tr> <td>Display of idle state</td> <td>The parameter is used to specify when the display is to switch over into the idle state.</td> </tr> <tr> <td>Installed in solid wall</td> <td>The parameter can be used to specify whether the display was installed in a solid wall. If this is the case, the parameter should be set on "Yes".</td> </tr> </table>	Adjusting the brightness to the ambient lighting	By activating or deactivating the parameter, the automatic adjustment of the display brightness to the ambient brightness is activated.	LED switch-on brightness night [%]	Setting the LED switch-on brightness for night in % via the -/+ buttons. Notice: The parameter only functions when a time profile with the application "LED day/night switchover" is available. The device (channel) must be linked with this application!	LED switch-on brightness day [%]	Setting the LED switch-on brightness for day in % via the -/+ buttons. Notice: The parameter only functions when a time profile with the application "LED day/night switchover" is available. The device (channel) must be linked with this application!	Switchover of display via the proximity sensor	Specifying whether the proximity sensor is to be used for switching the display.	Proximity sensor sensitivity	The parameter is used to specify the sensitivity of proximity sensor.	Haptic feedback	The parameter is used to specify whether a haptic feedback is to take place.	Simple view	This parameter is used to deactivate or activate the simple view. In this view the information is illustrated in reduced form. The extended view offers additional setting options and information.	Activating automatic return to the start page [s]	This parameter is used to set the number of seconds after which the display view changes automatically to the start page.	Screensaver mode	Specifying the form in which the screen saver is to be displayed.	Screensaver	Specifying the time at which the screen saver is to be activated.	Display of idle state	The parameter is used to specify when the display is to switch over into the idle state.	Installed in solid wall	The parameter can be used to specify whether the display was installed in a solid wall. If this is the case, the parameter should be set on "Yes".
Adjusting the brightness to the ambient lighting	By activating or deactivating the parameter, the automatic adjustment of the display brightness to the ambient brightness is activated.																								
LED switch-on brightness night [%]	Setting the LED switch-on brightness for night in % via the -/+ buttons. Notice: The parameter only functions when a time profile with the application "LED day/night switchover" is available. The device (channel) must be linked with this application!																								
LED switch-on brightness day [%]	Setting the LED switch-on brightness for day in % via the -/+ buttons. Notice: The parameter only functions when a time profile with the application "LED day/night switchover" is available. The device (channel) must be linked with this application!																								
Switchover of display via the proximity sensor	Specifying whether the proximity sensor is to be used for switching the display.																								
Proximity sensor sensitivity	The parameter is used to specify the sensitivity of proximity sensor.																								
Haptic feedback	The parameter is used to specify whether a haptic feedback is to take place.																								
Simple view	This parameter is used to deactivate or activate the simple view. In this view the information is illustrated in reduced form. The extended view offers additional setting options and information.																								
Activating automatic return to the start page [s]	This parameter is used to set the number of seconds after which the display view changes automatically to the start page.																								
Screensaver mode	Specifying the form in which the screen saver is to be displayed.																								
Screensaver	Specifying the time at which the screen saver is to be activated.																								
Display of idle state	The parameter is used to specify when the display is to switch over into the idle state.																								
Installed in solid wall	The parameter can be used to specify whether the display was installed in a solid wall. If this is the case, the parameter should be set on "Yes".																								
[1]																									
[2]	<p>Authorizations</p> <p>Menu item "Authorizations" is used to specify whether a user with installer authorization is required for the reconfiguration of the device.</p> <p>In addition, you can nevertheless assign users with read rights the authorization to switch this device.</p>																								
[3]	<p>Information about the device</p> <p>Listing of device information (device number, software version, etc.)</p>																								
[4]	<p>Maintenance</p> <p>You can start the device anew, read the device in again or reset it by tapping the respective buttons.</p> <ul style="list-style-type: none"> ▪ Restart ▪ Read device in again ▪ Reset 																								

7.3 Specifying or editing functions (buttons)

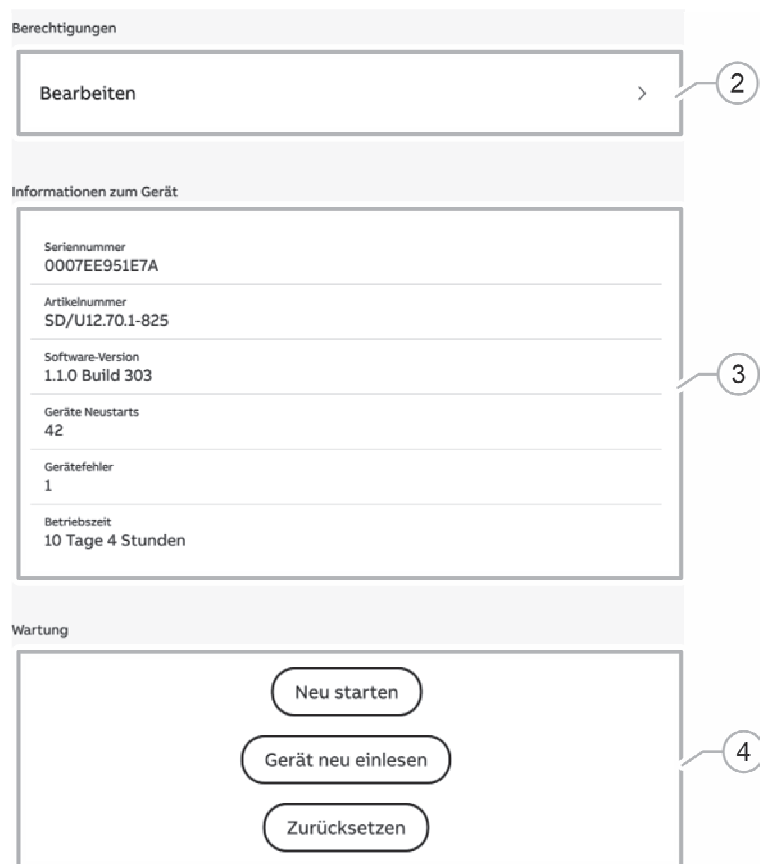

The settings are made via the display configuration of the Web-based user interface of the System Access Point.

In the display configuration of the web-based view of the System Access Point the buttons of the device can be freely equipped. All displays installed in the system can be selected.

Only displays are listed that have been previously positioned on the floor plan!

The allocated actuator channels can be positioned on the display via drag-and-drop from the list view. After the confirmation the configuration is taken over and becomes visible on the device after a few seconds.

7.3.1 Creating functions

To gain access to the display configuration, first you need to change to the menu provided. Proceed as follows from the start page:

Access via the building plan

1. Tap on the switch icon on the start (menu devices, scenes and groups) at the left edge of the screen.
 - The "Floor plan" opens.
2. Tap on the display in the building plan whose information you want to edit.
 - A new window with the information about the selected display opens.
3. Under menu item "Display configuration" tap on the "Configure" button.
 - The "Display configuration" opens.

You can then perform the configuration of the display in the display configuration. You can add devices or functions either via the room view or the type view.

- In the room view (at the top right in the display configuration under "Rooms") select the devices/functions according to their positioning in the building plan.
- In the type view (at the top right in the display configuration under "Type") select the devices/functions according to their type. The devices/functions are grouped here according to type (e.g. lights, scenes, actions, etc.).

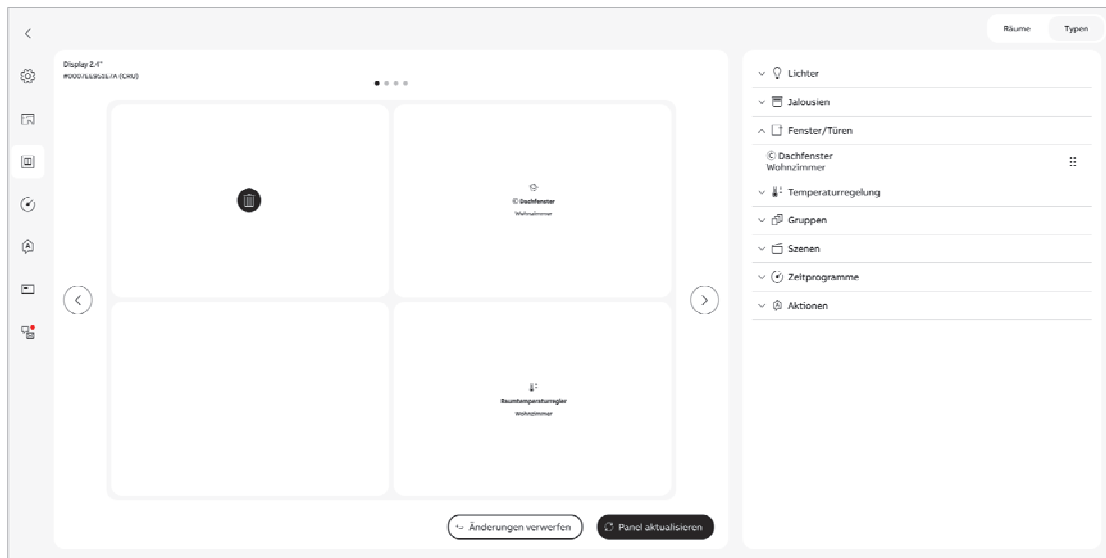

Fig. 27: Display configuration

Adjusting layout

In the display configuration you can adjust the layout of the individual operating pages of the display. The layout determines how much space individual control elements can occupy. The layout options of 1x1, 2x2, 1x2 and 2x2 are available.

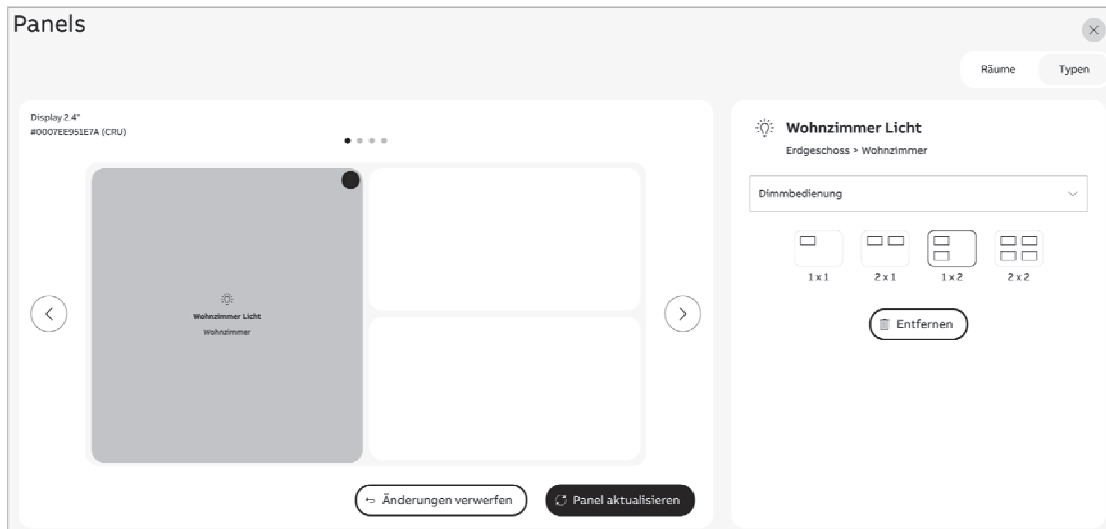

Fig. 28: Adjusting layout

Actuators/group selection

1. Select a room in the bar at the right edge of the screen.
 - The actuators and groups contained in the selected room are displayed in the list view. The sequence is portrayed in the following by means of a room temperature controller.

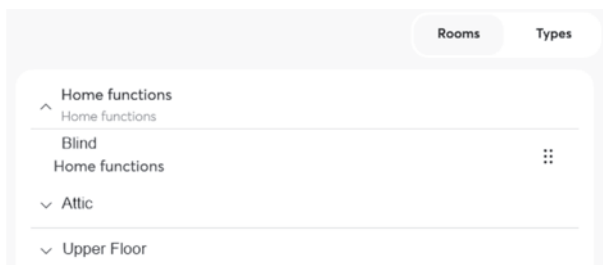

Fig. 29: Actuator/group selection

2. Select the room temperature controller by tapping on the points on the right side and pull the control element of the room temperature controller into the working area on the surface of the display.



Fig. 30: Control element view

3. Continue in this way and position the desired functions on the monitor of the display.
 - Additional buttons are always positioned under the previous button.
4. Confirm the adjustments with a click on the "Update display" button.
 - The new configuration is sent to the display. Then the new buttons are visible on the display and can be used.



Notice

4 configurable control elements can be displayed on a screen page.

7.3.2 Changing functions

1. If several displays are available, first select the appropriate display.
2. Tap on the display that is to be re-configured.
 - If only the position of the function or of the control element is to be changed, then the function can be shifted onto a free area via drag-and-drop.
3. Tap on the drop-down menu on the right edge of the screen of the respective function to adjust the function method.

7.3.3 Removing functions

1. If several displays are available, first select the appropriate display.
2. Tap on the display that is to be re-configured.
3. Select the function (button) to be removed.
4. Tap on the rubbish bin icon at the top right edge of the tile to remove the function. As alternative you can remove it via the "Delete" button in the menu at the right edge of the screen.
 - The selected function (button) is deleted from the monitor.
 - A transmission to the display is carried out via the "Update display" button.

8 Operation

8.1 General control and display functions

After the device has been connected to the power supply, the boot-up process starts. Then the parameterized main operating page (homepage) is displayed.

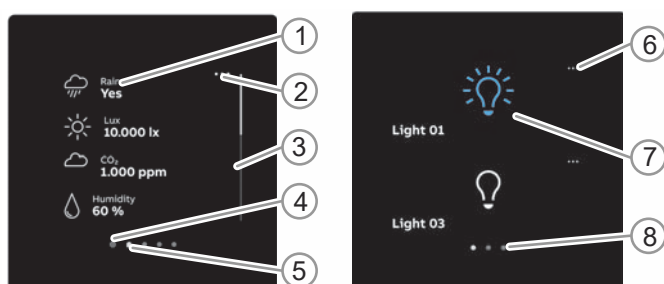

Fig. 31: Overview of operation

Pos.	Description
[1]	Display of information Display of all information recorded by the sensor, such as the weather.
[2]	Overview menu
[3]	Scroll bar By moving the scroll bar all recorded data can be viewed.
[4]	Dashboard All favoured control elements can be accessed via the dashboard.
[5]	Display of available operating pages
[6]	Editing function <ul style="list-style-type: none"> Next to each control element a heart icon (take-up into the favourites list) and a time program icon (take-up into the time program) is displayed. Next to each control element a heart icon (take-up into the favourites list) and a time program icon (take-up into the time program) is displayed. Reactivate the function by tapping on the tick, see chapter 8.2 “Control elements“ on page 45.
[7]	Touch-sensitive user interface Up to 4 functions per operating page can be positioned on the display. Aside from the start page, up to 11 further pages and up to 12 control elements can be created.
[8]	Display of available operating pages



- The individual operating pages can be called up by swiping the user interface (swiping to the right or left)
- The main operating page (homepage) is marked with a house icon
- The primary functions are activated by tapping with three or more fingers

8.2 Control elements

Control elements are used to fulfil the basic functions such as "Switching", "Dimming", "Blinds", "Scenes" and RTC. The elements can also contain switches, buttons and sliders.

Available are:

Button operation	Execution of function with a single press
Tapping operation	Execution of function by pressing and holding
Control operation	Shifting of a slider



Notice

Additional functions can be called up within some control elements (e.g. RTC) by swiping.

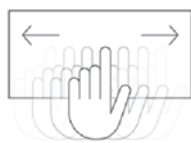

Specifying values

By swiping to the top or bottom, values, fan or dimming levels can be set on a control element.

Switching on/off

With a brief tap on the center or the icon of a control element it can be switched on or off.

Control element settings

Additional settings can be made by tapping on the three points at the top right edge of a control element.

8.2.1 Basic structures of control elements

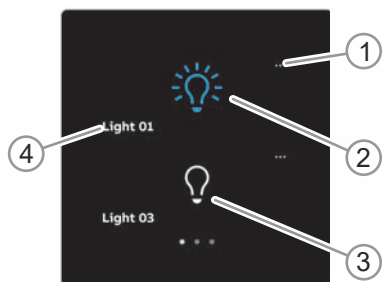

Fig. 32: Various statuses of the same control element

Pos.	Description
[1]	Control element settings
[2]	Device is active If the control element is active, the button is displayed in blue.
[3]	Device inactive If the control element is inactive, the button is displayed in white.
[4]	Name or channel designation of the device

8.2.2 Additional basic principles



Fig. 33: Basic principles

Function buttons of blind control elements can, for example, display the different switching points by means of alternating icons (e.g. alternating colour marking in the icon).



Fig. 34: Additional basic principles

Default settings of steps or levels (e.g. dimming steps, fan speed levels) are, for example, shown with different icons and numbers. In the following example, fan speed levels 1 and 3, as well as the automatic mode, are preset.

8.2.3 Adjustable control elements





Notice

The basic versions described here can be further adjusted.

Push-buttons (basic version)

Simple switches can be implemented with push-buttons. This makes light switches or switches for simple switching processes based on push-buttons possible.

Control	Status	Function
Switch		When operated, a changeover push-button sends out one of two values alternately and changes between two statuses (e.g. "On" and "Off").
Rocker switch		The rocker switch control element is graphically divided into two rocker switches. The rockers can be used to switch alternately between two values (e.g. "On" and "Off" for one lighting).



Blind (basic version can be further adjusted, e.g. with value display)

Blind control elements can be used to implement the activation of blinds, awnings, doors and other motor-driven actuators.

Control element	Status	Function
Blind		<p>Blinds can be operated via the control element. The button in the middle can display the status. A corresponding animation is displayed during the movement.</p> <p>Operating blind The blind can be moved by tapping on middle of the button. Depending on the parameter setting, in the first view it can be set by pulling the slider or by tapping on the control element how wide the blind is to open.</p> <p>Setting slats The slats can be set in the second view. For this, move the slider accordingly. The icons on the left next to the slider indicate degree of inclination of the slats.</p>

Dimmer (basic version can be further adjusted, e.g. with value display)

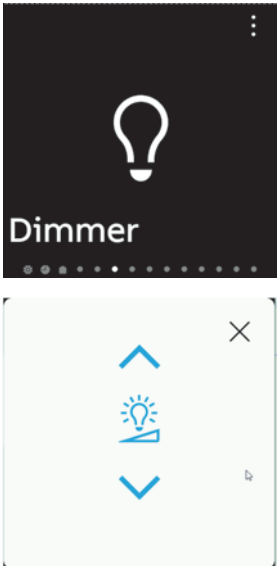
Dimmers can be used to implement convenient light switches with dimming functions.

Control	Status	Function
Dimmer		<p>The dimmer control element has a push-button in the middle for switching on and off. In the control element settings (accessible via the three points at the top right) it additionally has two buttons at the top and bottom for stepwise dimming (brighter / darker).</p>
Dimmer slider		<p>The lighting control can also be switched stepwise with the dimmer slider control element. By tapping and holding with simultaneous swiping movement upwards or downwards the lighting can be dimmed stepwise (brighter / darker).</p>

Scenes (basic version)

With control element "Scene" the user can start so-called scenes. Several actions can be combined in "Scenes" so that the user can create a certain light atmosphere with only one press of the button for example (several dimming actions).

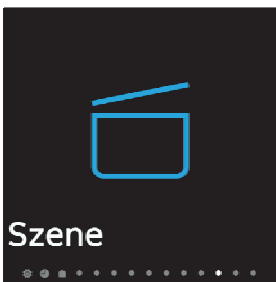
Control element	Status	Function
Scene (List)	 <p>The image shows a dark square control element with a blue icon of a scene (a rectangle with a line above it) and the word 'Szene' in white below it. At the bottom, there is a row of small white dots, with the fourth dot from the left being larger and brighter than the others.</p>	<p>Linked scenes can be switched via the control element.</p> <p>The scene must first be selected on the display. The selected scene is then started via the push-button.</p> <p>Notice The scene to be called up must be allocated correspondingly in the DCA.</p>

Fan switch (basic version)

Fan switches (step switches) can be used to implement switching sequences. A step switch, so to speak, combines several push-buttons into one control element.

Control element	Status	Function
Fan switch (step switch)	 <p>The image shows a dark square control element with a white fan icon in the center and a blue number '1' to its right. Below the icon is the word 'Lüfterschalter' in white. At the bottom, there is a row of small white dots, with the fourth dot from the left being larger and brighter than the others.</p>	<p>The fan switch has, dependant on the configuration, up to four buttons for the operation of functions.</p> <p>By pressing the top/bottom button several times, one reaches a further step higher or lower.</p> <p>The icon in the middle can be animated during adjusting.</p> <p>It is also possible to display the steps.</p>

Slider value

- Value sending elements (sliders) can be used to display values in different formats and to send them to other devices.

Control element	Status	Function
Value sending element (value slider)		Value sending elements can be used to display values in different formats and to send them to other devices. With "Value slider" the slider can be used to change values. The changed values are then sent.

Room temperature controller (basic version)

Air conditioners can be controlled with the control element for room temperature controllers.

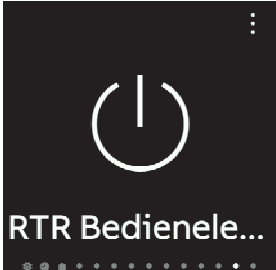
Control element	Status	Function
RTC control element (extension unit)		A room temperature control can be switched via the control element (e.g. "Heating"). Setting options are called up by tapping. A switch between the setting options can be made by swiping to the left (temperature, mode, etc.).

RGBW operation (basic version)

Specific settings can be made for corresponding lamps (LEDs, Philips Hue, etc.) with the RGBW control elements. For example, the colours can be changed or the warm-white component can be adjusted.

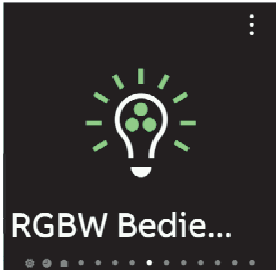
Control element	Status	Function
RGBW operation		The lamp is switched on or off with a press of the control element. The icon shows the brightness content and the set colour. In line with the lamp types and presets in the DCA, additional functions can be called up (in the example via the arrow), e.g. colour or white control. The colour set last remains. Additional settings can be made by tapping on the three points in the top right area of the control element.

Audio control (basic version)

All audio settings for connected audio devices can be easily controlled with the aid of this control element.

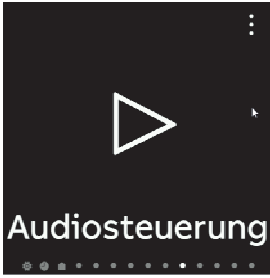
Control element	Status	Function
Audio control		<p>Corresponding to the default settings in the DCA, a variety of audio functions can be called up directly via the buttons.</p> <p>The audio control can be started/stopped by tapping. Additional functions such as forward winding and rewinding, volume settings and the playlist are available.</p>

Split Unit Control

Split Unit control elements can be used to make settings for climate control devices. This, for example, allows the setpoint temperature to be adjusted in cooling mode.

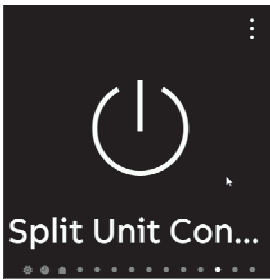
Control element	Status	Function
Split Unit control element		<p>A Split Unit can be controlled via the control element (e.g. for heating and cooling functions). Setting options are called up by tapping. A switch between the setting options can be made by swiping to the left (temperature, mode, etc.).</p>

VRV control element

VRV control elements can be used to make settings for heating and climate control devices. This, for example, allows the setpoint temperature to be adjusted in cooling mode.

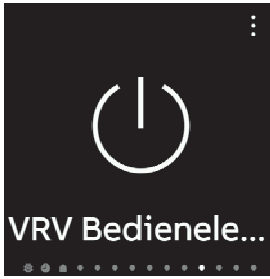
Control element	Status	Function
VRV control element		<p>A VRV can be controlled via the control element (e.g. for heating and cooling functions). Setting options are called up by tapping. A switch between the setting options can be made by swiping to the left (temperature, mode, etc.).</p>

8.3 Special functions

8.3.1 Return to the previous page

The previous page can be opened again by swiping to the left.

8.3.2 Fault and alarm messages

The display offers protection and information via the notification center. This enables you to view information about malfunctions or faults. Message contacts, sensors and their functionality can be monitored.



Notice

Depending on the parameterization, only certain functions are available in the application

The user can view, acknowledge and delete the call history and messages via the notification center.

Messages

Current and archived messages can be displayed and edited in the fault and alarm messages. There are different types of messages. Each category has its own icon.

- Information
- Warning
- Fault message

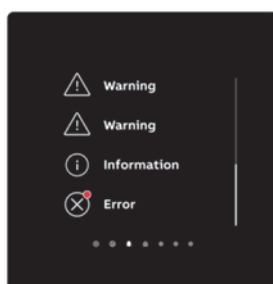

Fig. 35: Fault and alarm messages

Current fault or alarm messages are marked with a red dot next to the warning icon.

1. The message text can be viewed by tapping on a message.
2. The messages can be shifted into the archive by swiping to the left.

Exporting messages (notifications) to the micro SD card:

Confirmed and archived messages can be exported.

1. Tap in the archive on the button "Copy all to SD card".
 - The data are copied to an SD card.

**Notice**

Please note that an SD card must be in the device.

**Notice**

The export function must have been parameterized!

Deleting messages (notifications):**Notice**

Only archived messages can be deleted.

1. Select a message.
2. Scroll completely down within the message.
3. Tap on the "Delete" button to delete messages.

Deleting archived messages (notifications):

1. Select a message in the archive.
2. The message can be deleted by swiping to the left.
3. Tap on the "Delete all" button to delete all messages.
 - All messages are deleted.

**Notice**

Also the entire list can be deleted.

- For this, tap on "Delete all".

8.3.3 Time programs

Time programs can be used to call up functions according to the time automatically. This, for example, allows the holiday function to be started and set up.

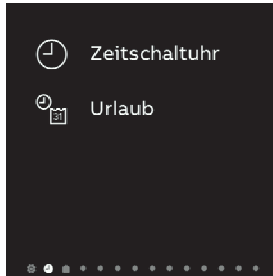

Fig. 36: Overview of the time program

Time programs are configured via the Web-based interface of the System Access Point. The precise procedure you find in the associated product and system manual.

8.4 Inserting the micro SD card (SDHC)



Notice

Access to the card slot is possible only in the installed status, see chapter 6.6 "Dismantling" on page 25.

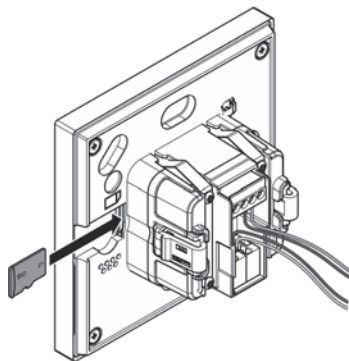

Fig. 37: Inserting the micro SD card (SDHC)



Notice

- The transfer of data to the device via the micro SD card is possible only with existing power supply.
- Supply ABB i-bus® KNX / free@home Bus must be connected!

8.5 System settings

Within the system settings general adjustments appropriate to the device can be made. These are described as follows.



Fig. 38: System settings

The system settings are called up via the start page of the display. The start page is marked with a small house icon at the bottom edge of the screen.

The following settings can be made.

Pos.	Designation	Description
[1]	Sensors	All linked sensors are displayed in the top area of the system settings (the graphics show the window contacts).
[2]	Cleaning blockage	To prevent undesired entries during cleaning of the display, the display can be set into a 30-second cleaning mode.
[3]	System Information	The current system information can be viewed via option "System information".

8.5.1 System settings - System information

This page provides general system information.

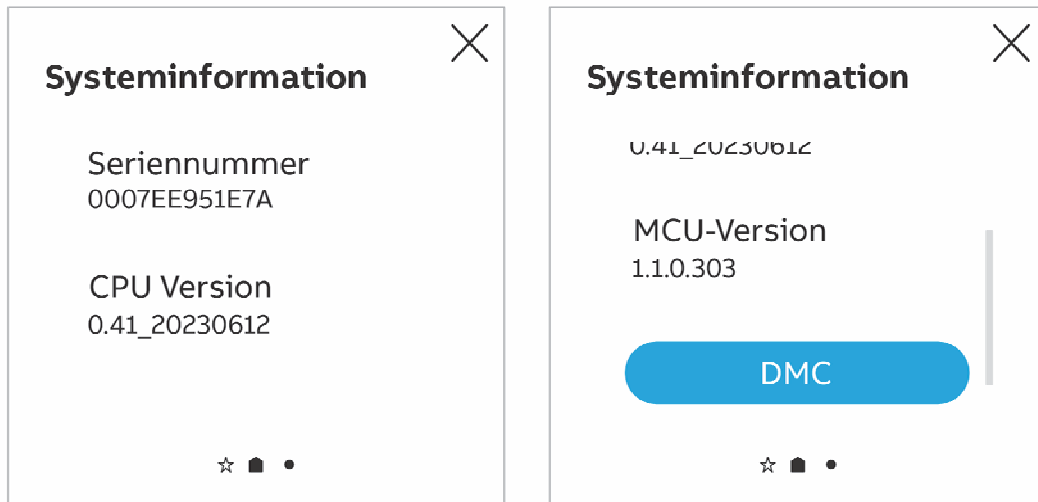

Fig. 39: System settings - System information

8.5.2 System settings - Firmware update

Firmware updates are performed with the aid of the SD card.



Fig. 40: Firmware update via SD card

1. Change to the "Firmware update" menu under system settings.
2. Tap on the "Update via SD card" button.
 - The system then searches for available updates. If there is a new update on the SD card, it will be listed in the dialogue.
3. Select the file by activating the checkbox.
4. Tap on the "Install update" button.
 - The update is carried out.
 - The successful installation is displayed in the dialogue. The display is then restarted independently.

8.5.3 System settings - Reboot

A reboot of the system can be carried out via the "Reboot" button.



Abb. 41: Reboot

8.5.4 System settings - Cleaning blockage

To prevent undesired entries during cleaning of the display, the display can be set into a 30-second cleaning mode.

1. Tap on "Activate".
 - The cleaning blockage is activated, and the remaining time is counted down in the display.

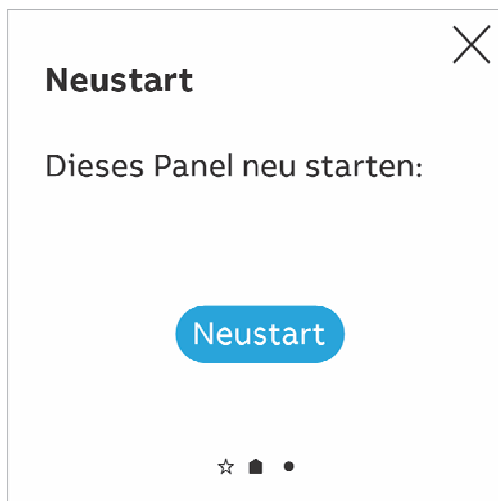
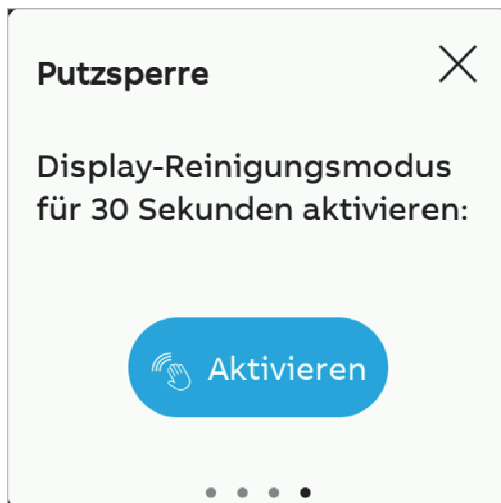

Fig. 42: Cleaning blockage

8.5.5 System settings - Sensors

The status of the respective sensors can be viewed via the Ansi sensors. Also switching processes can be carried out (e.g opening or closing the window).

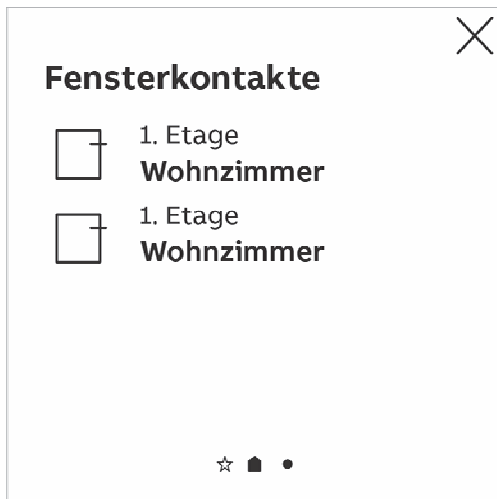

Fig. 43: Sensors - Window contacts

9 Update

The update / configuration file can be transferred to a micro SD card, see chapter 8.4 “Inserting the micro SD card (SDHC)” on page 57. This micro SD card can be inserted into the display to transfer the data.

**Notice**

- The micro SD card must be formatted with FAT32 before use.
 - If necessary, use an adapter for the micro SD card to transfer the data from the PC to the card.
-
- Firmware update, see chapter 8.5.2 “System settings - Firmware update” on page 60

10 Maintenance

10.1 Cleaning

**Note**

Observe the "Cleaning blockage" function, see chapter 8.5.4 "System settings - Cleaning blockage" on page 62.

**Caution! - Risk of damaging the device!**

- When spraying on cleaning agents, these can enter the device through crevices.
 - Do not spray cleaning agents directly onto the device.
- Aggressive cleaning agents can damage the surface of the device.
 - Never use caustic agents, abrasive agents or solvents.

Clean dirty devices with a soft dry cloth.

- If this is insufficient, the cloth can be moistened slightly with a soap solution.

11 Notes

12 Index

A	
Accessories	13
Add device	27
Allocation of devices	26
C	
Changing functions	44
Circuit diagrams	17, 20
Cleaning	68
Commissioning via ABB-free@home®	26
Connection	20
Connection, installation / mounting	19
Control elements	46, 47
Additional basic principles	49
Adjustable	50
Basic structures	48
Creating functions	40
D	
Device overview	14
Dimensional drawings	16
dismantling	21
Dismantling	25, 60
E	
Electrical connection	20, 23, 24
Environment	11
F	
Fault and alarm messages	57
G	
General control and display functions	46
I	
Identification	28
Identification label	28
Improper use	6
Information and symbols used	5
Information on protection of the environment	11
installation sites	21
Intended use	6
M	
Maintenance	68
Micro SD card (SDHC)	60, 67
Mounting	21, 23, 25
N	
Notes	69
Notes on the instruction manual	4
O	
Operation	7, 46
Other settings	36
Overview of types	13
P	
Parameter settings	31
Channel	34
Planning instructions	19
Product Overview	12
Q	
Qualification of personnel	7
R	
Removal protection	22
Removing functions	45
Requirements for the electrician	19
Return to the previous page	56
S	
Safety	5
Safety instructions	10, 19
Scope of supply	13
Select device	30
Serial Number	28
Setting options per channel	30
Special functions	56
Specifying a name	28
Specifying/editing buttons	33, 40
Specifying/editing functions	33, 40
System Access Point	26
System settings	61
Cleaning blockage	65, 68
Firmware update	9, 63, 67
Reboot	64
Sensors	66
System information	62
T	
Target group	7
Technical data	15
Time programs	59
U	
Update	67



Busch-Jaeger Elektro GmbH
A member of the ABB Group

Freisenbergstraße 2
D-58513 Lüdenscheid, Germany

<https://new.abb.com/en>

Customer service:
Tel.: +49 2351 956-1600