

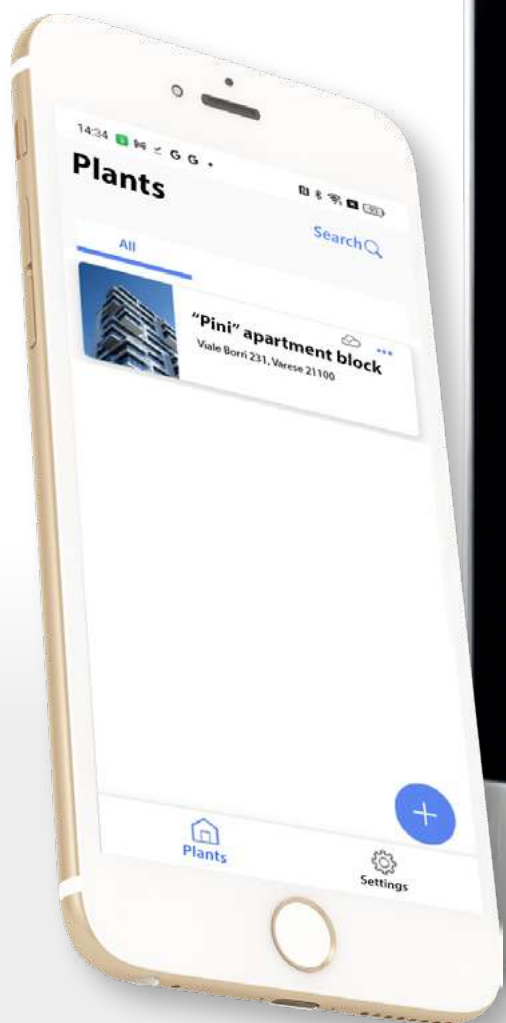

Home + Project





Home + Project





Guide to reading the manual

Welcome to the manual reading guide.

This section has been created to give you a clear and complete understanding of the contents of this manual.

By following these guidelines, you can maximise the effectiveness of your learning and user experience.

This manual can be read in two main ways:



1 – Full reading of all the chapters

If you want to know in depth every aspect of the device, we recommend the full reading of all the chapters.

This allows to explore each aspect in detail, for a complete and thorough understanding of the system.

You can start with the [interactive index](#) which gives a complete overview of all the topics, and read through the manual in the suggested order, or use the interactive links to go from one section to the next.



2 – Quick guide to first installation

If you are looking for quick and practical instructions on how to complete your first configuration, follow the “STEPS” in the [Quick Start Guide](#).

By following the step-by-step instructions (STEPS), you can learn the quickest procedure to complete an initial configuration of the system.

The pages of the manual that are part of a STEP contain graphic indications to help with navigation.

Navigation bar:

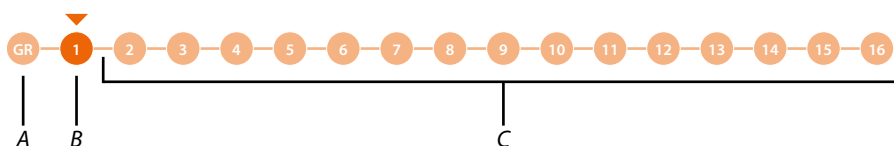

A Back to the guide with the description of the steps.

B Current step.

C Next steps, click to navigate through the steps.

At the end of each step, there is also a link to the next step:

[GO TO THE NEXT STEP >>](#)

This method is very convenient to enable you to have a working system up and running in no time. However, we recommend that you learn more about the system by reading the entire manual. Although some paragraphs may initially seem less relevant, they may prove useful in the future. In addition, by reading the manual in its entirety, you may discover features you did not know existed and which could significantly improve your use of the system.

Contents

General information	6
Warnings and recommendations	6
Preliminary requirements	7
Minimum PC and Smartphone Requirements	7
Network requirements	7
Installation	8
Front view	8
Rear view	9
Dimensional data and installation heights	10
Mounting	11
Disassembling	13
Fundamental concepts	15
Acronyms	16
Devices	16
Home + Project App	16
Type of system users	17
Residents	17
Staff	17
Use of EP	19
Call an apartment using address book	20
Call an apartment using a code (numeric or alphanumeric)	22
Call an apartment using Block/Riser/Floor/Apartment	24
Call the guard station	26
Access using a code	28
Access using a Badge	29
Quick configuration guide	30
Download the Home+Project app	31
Account registration on the installer cloud	32
Forgotten password	34
Authentication	35
App Home Page	36
System creation and first configuration	37
Configuration in Address Book call mode	37
Configuration in Code or Code plus Address Book call mode	41
Configuration in Block/Riser/Floor/Apartment call mode.	45
System management	50
System sharing	51
Delete the system	55
App settings	56
Account management	57
Help	65
Update Center	66
System Home Page	69
Entrances ("Installer" User)	70
Manage the entrances	70
Create a new entrance	70
Edit the entrance	71
Associate the devices with the entrances	72
Association with the EP	72
Association with the keypad	80
Association with an RFID	83
Manage the devices associated with the entrances	86
Firmware update	87
Show the settings on the device (only for EP)	88
Device reset	89
Modify the device	90

Entrances ("Building manager" user)	91
Audio parameters	92
Appearance	93
Synchronisation	95
Residents	97
Apartment management	98
Contact	98
Input	103
Badge	104
Access code	108
Badge	110
Create a resident badge	111
Create a staff badge	112
Guard station	113
Additional services	114
Staff	115
Temporary staff	116
Regular staff	117
Messages	121
Parameters and settings	123
Structure	124
Device info	125
Select the language	125
Call modes	126
Access code	127
System activation	129
Network	132
Send problem details	136
Configurations from device	137
Device settings	137
Call test	137
Volume setting	139
Device info	140
Reset	141
Home + Project desktop tool	143

General information

Warnings and recommendations

It is important to read this manual carefully before proceeding with the installation. The warranty becomes automatically void in case of negligence, improper use, tampering by unauthorised personnel.

NOTE: an internet connection is required for the connection between the device and the smartphone. In addition, the smartphone and Linea 5000 must be able to connect to each other via Bluetooth.

To configure Linea 5000, the installer must install the Home+Project app on his smartphone.

To use the service offered the End customer must install Home+Security and acquire the technical equipment which allows access to the Internet, on the basis of an agreement made by the Customer himself with an ISP (Internet Service Provider). BTicino plays no part in this.

The integration and good working between Linea 5000 and the apps may depend on:

- a) quality of the Bluetooth signal;
- b) type of access contract to the system internet;
- c) type of data contract on the smartphone.

When one of these 3 elements does not conform with the specifications required for product operation, BTicino accepts no responsibility for any faults.

We would like to inform you that the service provided by BTicino by means of remote use via the apps involves the use of data. The cost linked to data usage depends on the type of contract which the customer has with his ISP (Internet Service Provider) and is solely the customer's responsibility.

ATTENTION: the images of this manual are only indicative, and therefore may not exactly represent the characteristics of the product.

Warning: the device only supports Latin, Greek and Cyrillic characters, so when entering texts in the app (name customisation, descriptions, messages, etc.) use only these characters.

Preliminary requirements

Minimum PC and Smartphone Requirements

SMARTPHONE REQUIREMENTS:

- ANDROID®: it requires Android® 10 and later
- iOS: it requires an iPhone or iPad running iOS 12.0 or later

PC REQUIREMENTS (for Desktop tool version):

- 500MB disk space
- Network card
- Internet connection
- Recommended browser: Google Chrome
- Operating systems: from Microsoft Windows 10; from macOS 10.15 Catalina

Network requirements

The network must have the following features:

- Band frequency: from 2.4 to 2.4835 GHz, 802.11 b/g/n, channel 1-11
- Network protocol used to encrypt the password:
 - a. WPA AES
 - b. WPA TKIP
 - c. WPA2
 - d. WPA2 AES
 - e. WPA2 TKIP
- Minimum Wi-Fi signal reception = - 60 dB

Installation

Front view

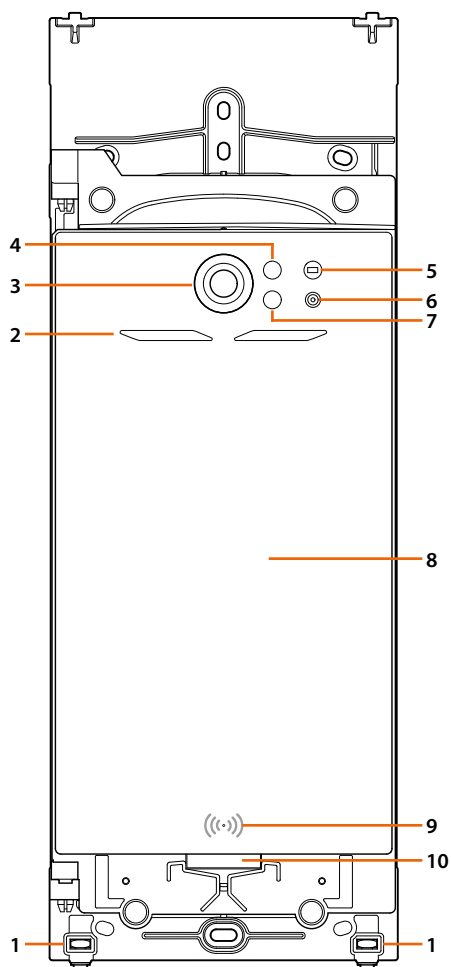

1. Locking screws for finishing frame
2. Viewing field lighting LED
3. Camera
4. Proximity sensor receiver
5. Lighting sensor
6. Microphone
7. Proximity sensor emitter
8. Touch display 7"
9. RFID badge reader
10. Speaker



Rear view

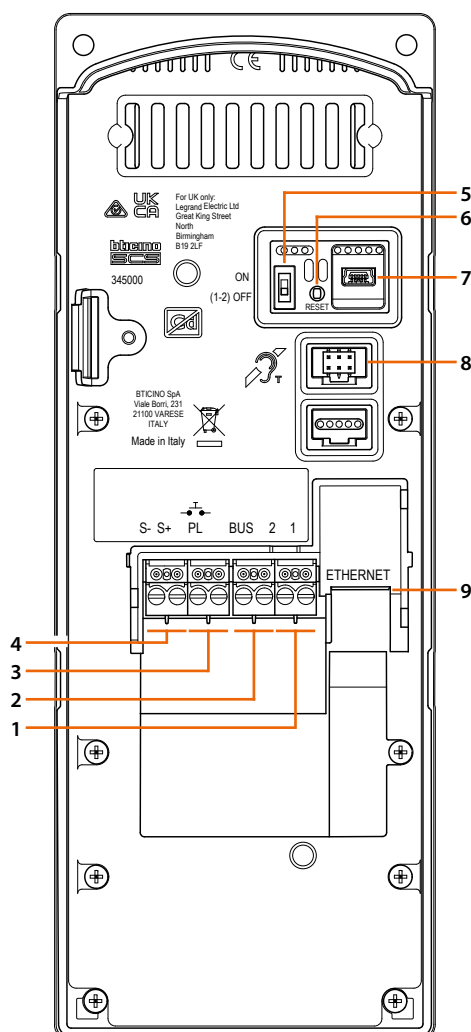

1. Clamp for local power supply.
2. BUS clamp.
3. Clamp for local door release pushbutton.
4. Clamp for electric door lock control (18V 4A impulsive - 250 mA holding current 30 Ohm max).
5. Micro-switch to enable the additional power supply (activate the function with device not powered). ON=enabled; OFF=disabled.
6. Pushbutton to reset to the factory settings. Press and hold down for 10 seconds then release. A confirmation message appears on the display. Press to confirm the choice.
7. Service mini-USB connector.
8. Connector for the connection of the inductive loop module.
9. RJ45 connector.

Dimensional data and installation heights

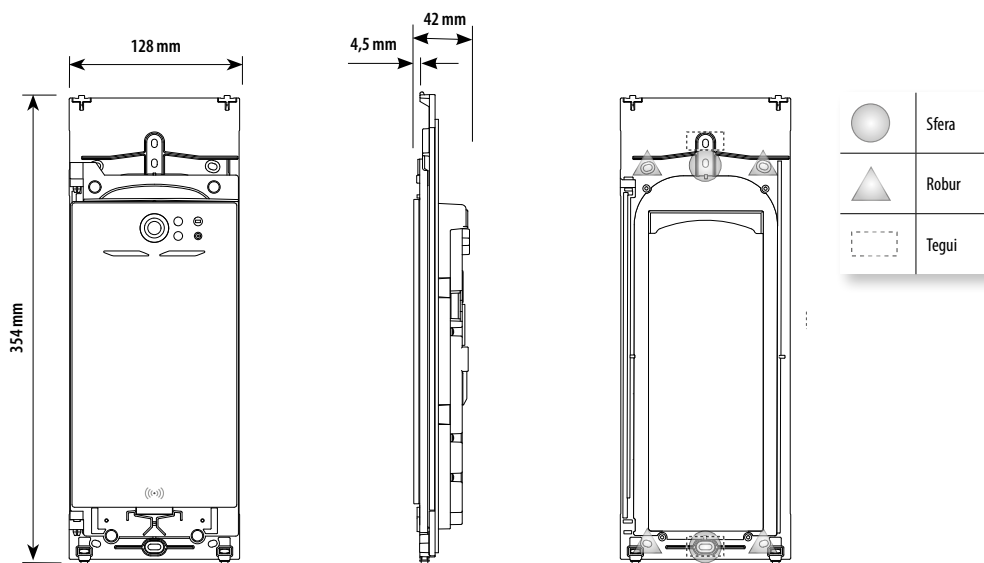

Fixing points of the frame to the box

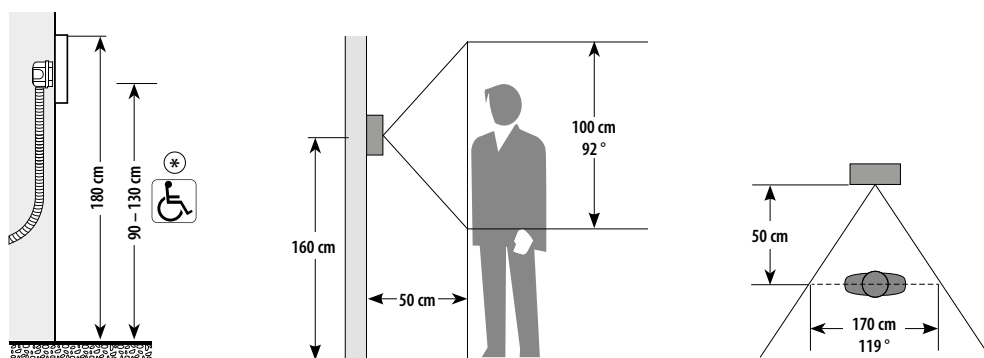

* Recommended height, unless different regulations are specified.

Mounting

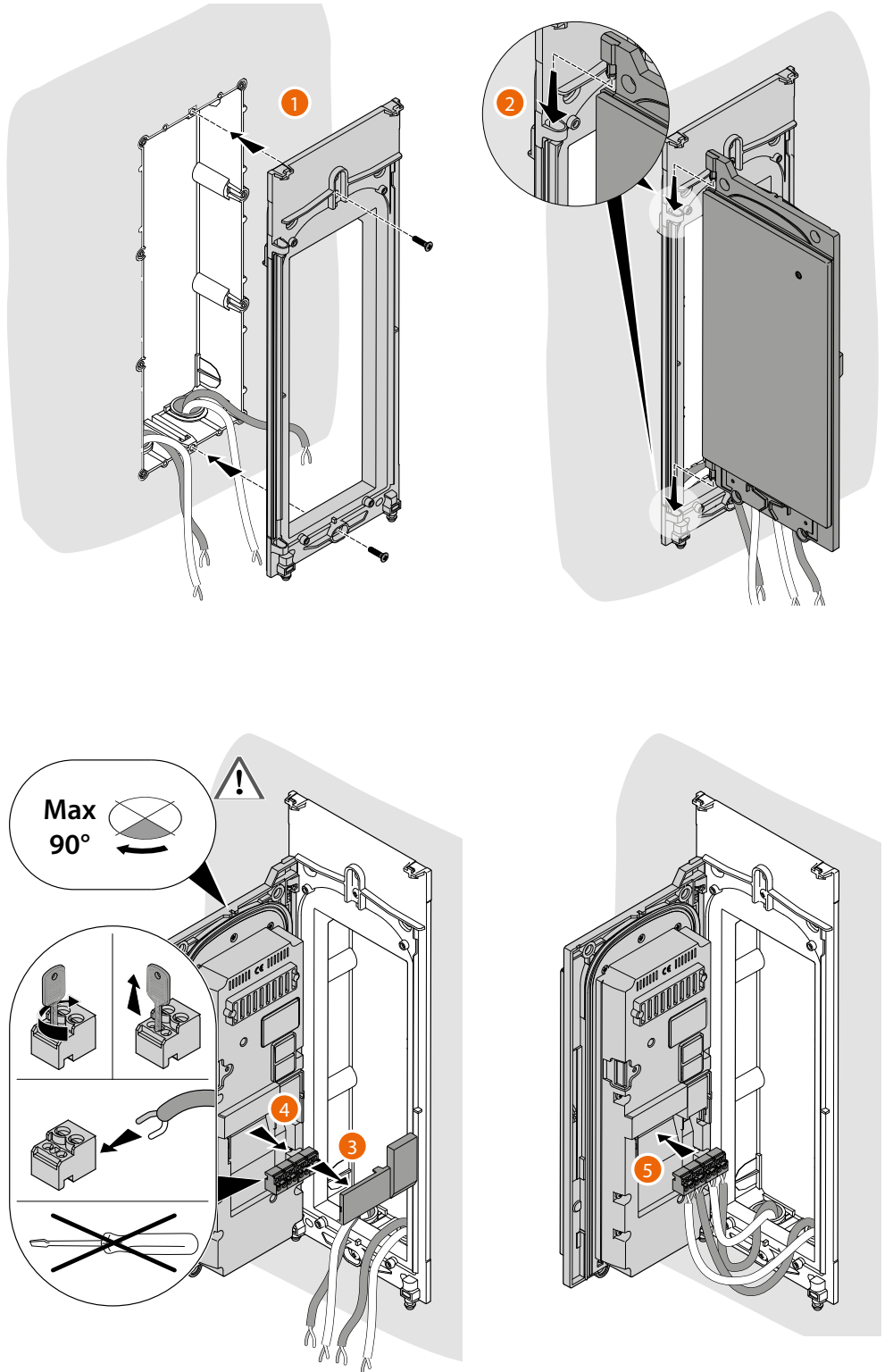

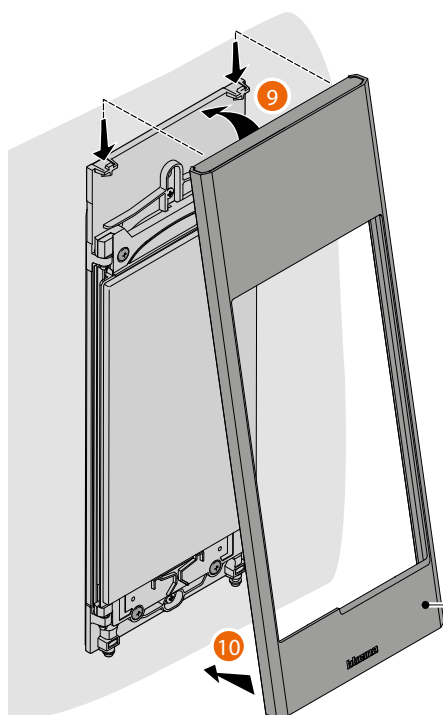
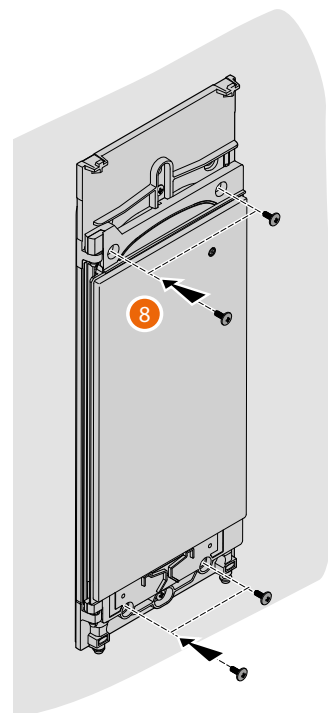
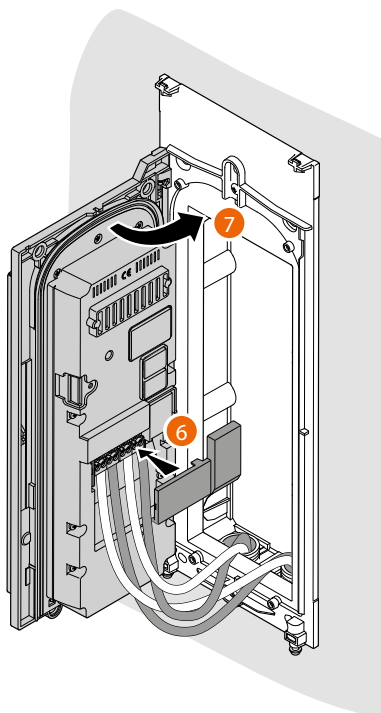

* 345101/02/03/04/05
345131/32/33/34/35

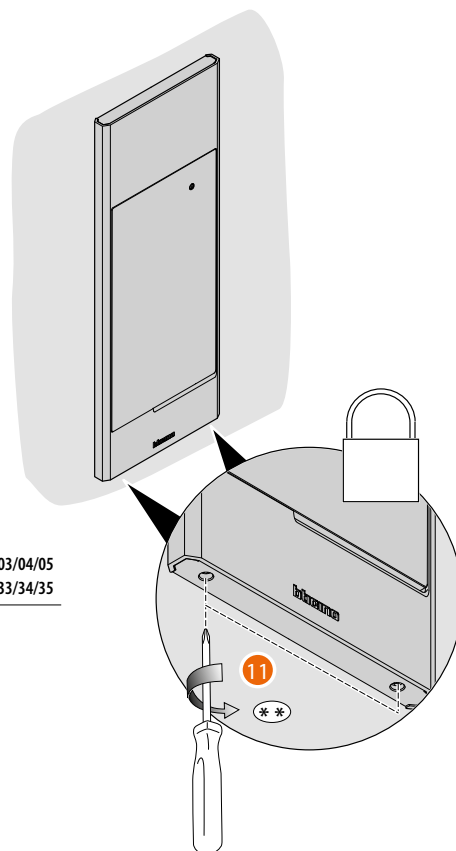

* Item to be purchased separately.

** To avoid damages, end the operation as soon as the screws reach the end of travel.

Disassembling

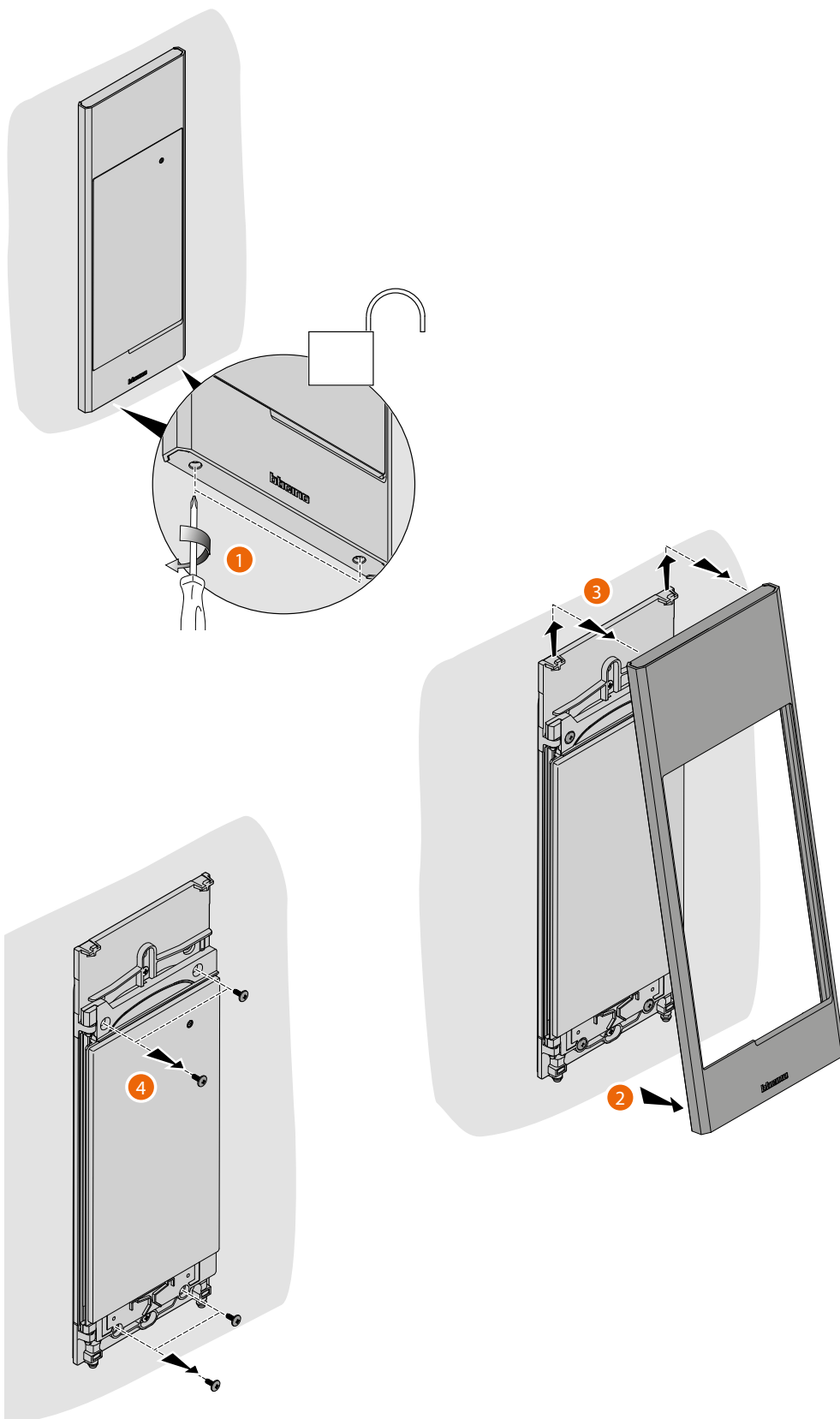

- GR 1 2 3 4 5 6 7 8 9 10 11 12 13 14 15

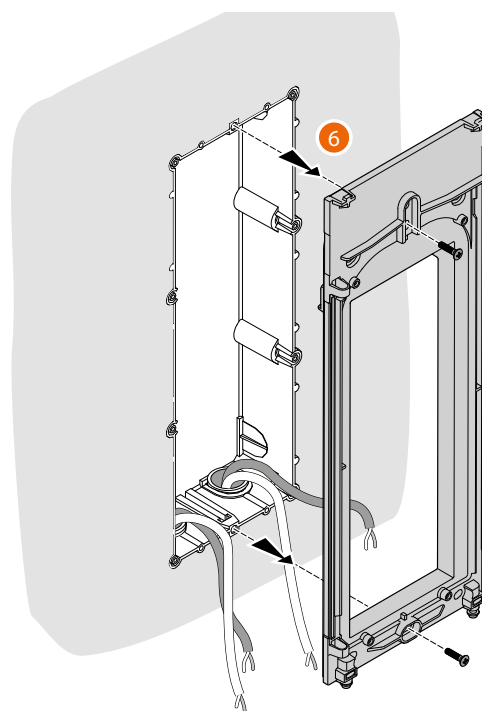
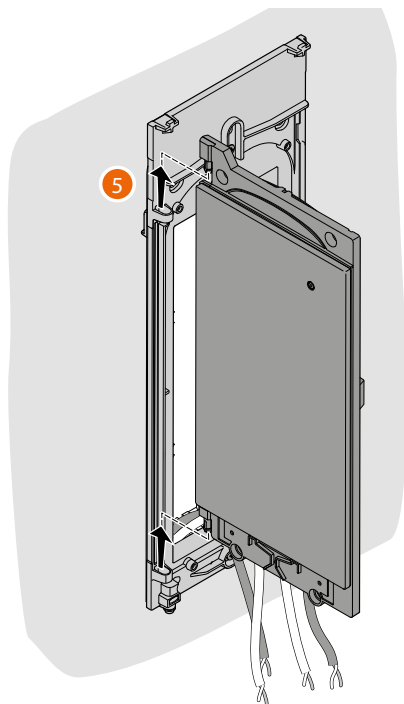

Fundamental concepts



There are several ways to configure devices, particularly the entrance panel. The recommended method to make the most of the system features can be split into 2 phases:

At the office

Most configurations (system creation, structure creation, compiling the address book, badge and entry access codes) can be completed in the office using the smartphone and the [Home + Project](#) app or, for greater convenience, using the PC and the [desktop version of the app](#).

On the system

After installing the devices, you must send the configuration to them via Bluetooth from your smartphone with the Home + Project app installed.

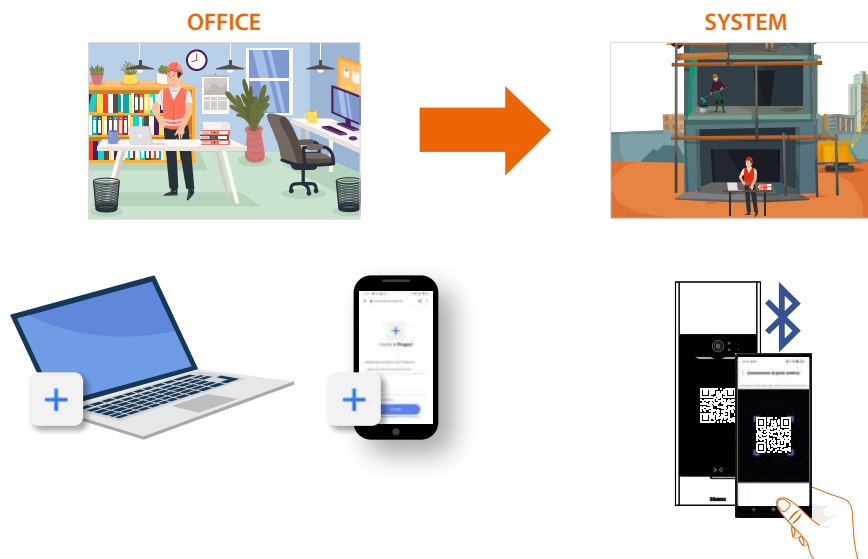

Acronyms

In this manual, for easy reading, the abbreviated device name is used as in the list.

- **EP**: Linea 5000 display module item 345000
- **Keypad**: Linea 5000 additional keypad module item 345500
- **RFID**: Additional RFID Smart access module
- **BRFA**: Block Riser Floor Apartment

Devices

The devices of the Linea 5000 system are the EP, the keypad, and the smart reader.

EP 345000: Main device where the "intelligence" of the system resides.

- it manages calls to the internal units
- accesses via Bluetooth, numerical codes and badges

345500 - 345510 keypad module: accessory that allows access to residents by entering a valid numeric code.

RFID 345520 smart access module: accessory that allows access to residents using a valid RFID badge.

The keypad and the reader cannot be installed individually but always need to be connected to at least one EP.



Home + Project App

The Home + Project app is necessary in order to configure and manage the Linea 5000 system. It allows to:

1. Manage a single address book for all the entrance panels of the system;
2. Configure the system devices by downloading the configuration via Bluetooth;
3. Update the device firmware;
4. Associate resident users with their apartments, so that they can take advantage of dedicated functions through the Home + Security app.

The configuration can be sent to the devices in 2 ways:

Manual:

The connection to the EP is made by Bluetooth, connecting all the EPs of the system one at a time. The configurations that can only be sent in this way are:

- add/remove/change apartment;
- add/remove/change entrance;
- add/remove/change guard stations.

Automatic with propagation:

This allows to send configurations via Bluetooth to a single EP, which will then propagate the configurations to the others in the system (if any) via SCS.

The configurations that can be sent in this way are:

- add/remove/change the residents of an existing apartment;
- add/remove/change badges;
- add/remove/change access codes;
- add/remove/change staff users;
- add/remove/change messages.

The system may be modified in two ways using the Home + Project app:

Local:

Connecting the EP via Bluetooth, the EP must be in the Bluetooth range of the smartphone.

Remotely:

Connecting the EP to the Internet (via Wi-Fi or Ethernet). Not all configurations will be possible remotely. For configurations that are not possible through the internet, a notification will invite to stand close to the device and send any modifications manually using the Bluetooth connection.

Type of system users

Two types of users are enabled to configure and manage the devices:



Installer

This user has access to all the functions and is the user who will follow the installation to the end, from structure to residents, to device parameters.

The installer cannot invite/remove users with administrator rights.



Building manager

This can fully manage the invitations of other users, both installers and administrators, and can also:

- Modify the address book;
- Modify system parameters.

The building manager cannot make structural changes or activate the system.

When creating the system, the system assigns a dual role of both installer and administrator. Subsequently, the roles will be split, so that each user only has access to the functions for which they are responsible.

Residents

When creating the system, a structure is also created; the lowest level of the structure is the apartment.

A resident will be created for each apartment. The resident will be able to:

- Answer the incoming calls from the EP;
- Open the EP door lock;
- Access to the structure using a code or a badge.

A resident can also **invite via the Home+Security app a registered user** to manage the apartment, also using the app.

This will allow the invited user to:

- Open the door lock via Bluetooth;
- Manage the labels of their own apartment (add/remove/change) via Bluetooth;
- Or remotely if the EP is connected;
- Manage numeric access codes (to open locks) and temporary codes via Bluetooth;
- Or remotely if the EP is connected.

Staff

In addition to residents, it is also possible to grant access to the structure to non-residents who need to access independently to provide services to residents.

The resident assigns the appropriate Staff profile for the service provided by the individual, allowing temporal or regular access.

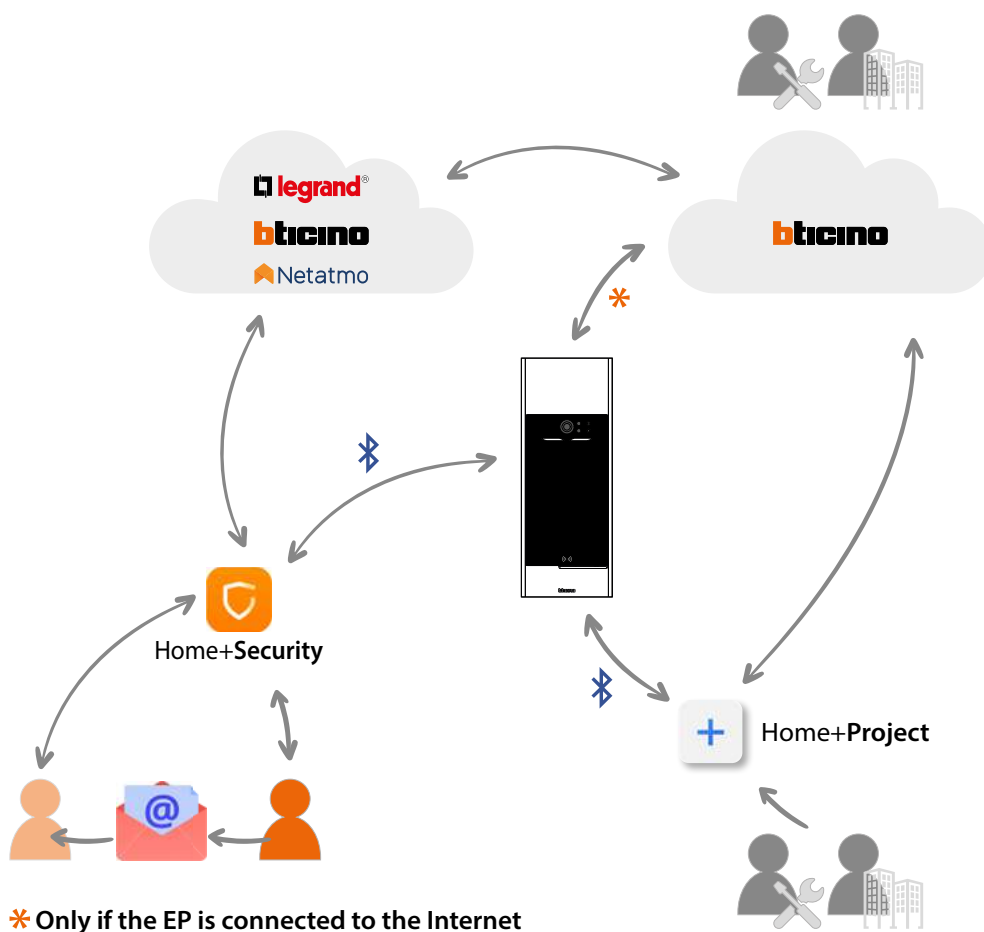

ICON LEGEND



Installer user



Building manager user



Resident



Home+Security invited user

Use of EP

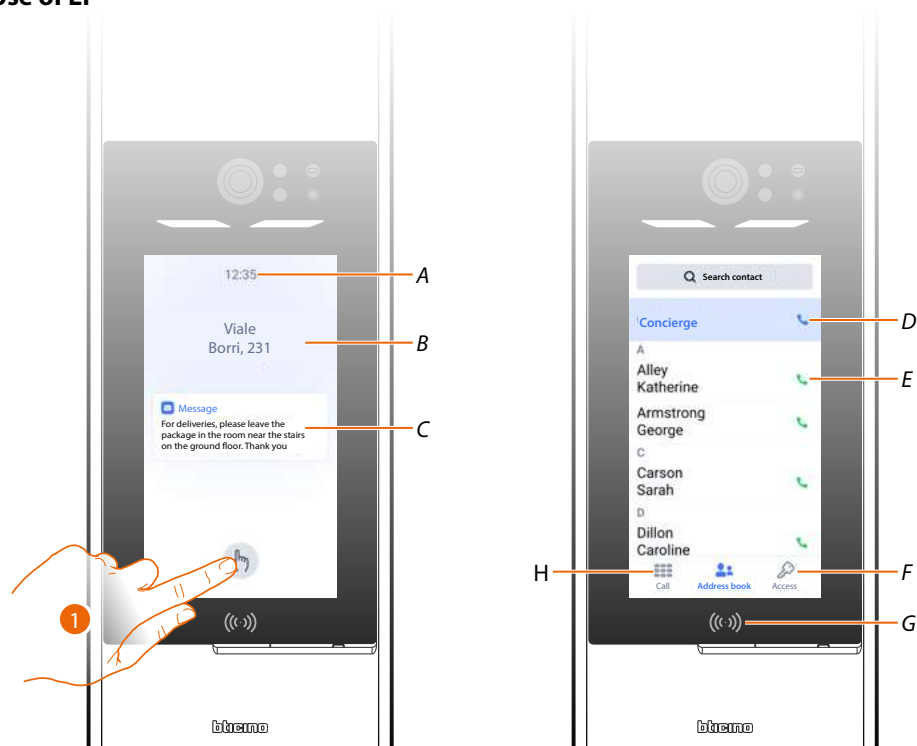

A Time.

B Welcome message (see section for [setting](#))

C Manager message (see section for [setting](#))

1. Touch to call or access.

D [Call the guard station](#)

E [Call an apartment using the address book](#)

F [Open the access page using a code](#)

G [Badge access reader](#)

H [Open the call page using a code or block/riser/floor/apartment](#)

NOTE: the welcome and home page images are only examples; the actual appearance depends on the configuration.

In the example shown, a code call has been configured and the address book option has been enabled.

Call an apartment using address book

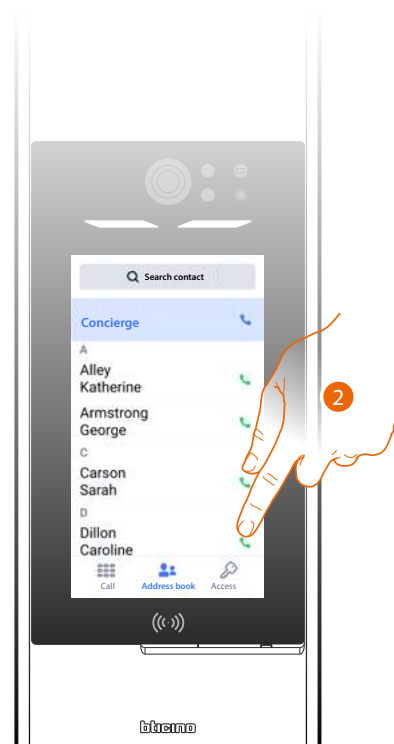
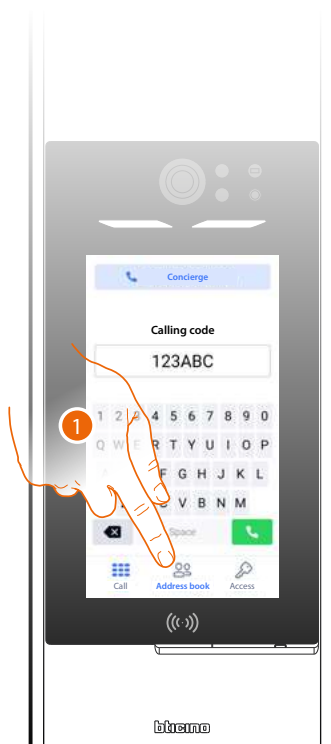

1. Touch to open the address book page.
2. Touch to call the desired resident.



3. The call is in progress, touch to end if necessary (A).
4. The resident has answered.

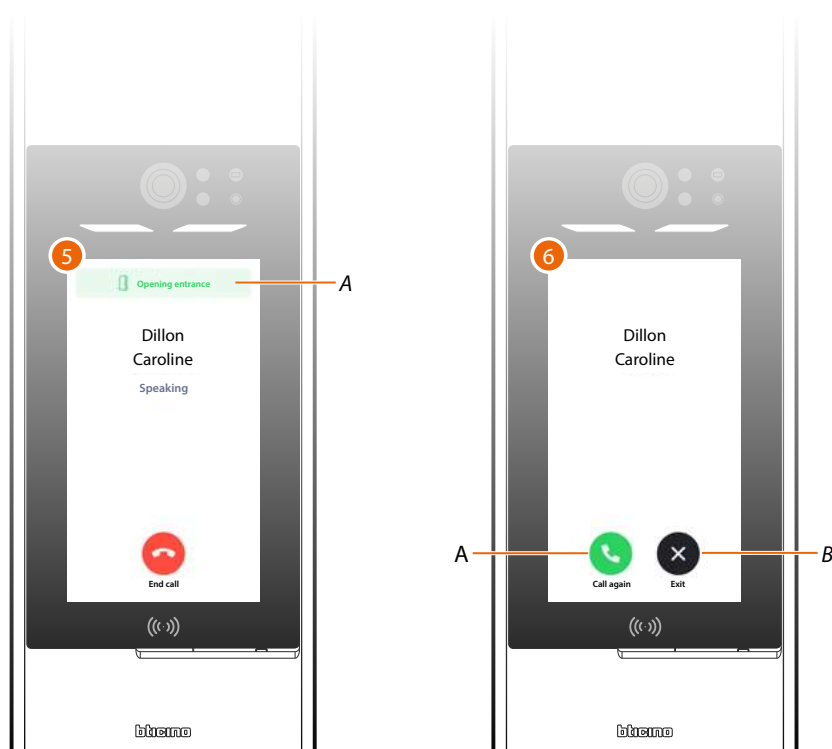

5. The resident has opened the door lock (A).
6. The call is ended, recall (A) or exit (B).

Call an apartment using a code (numeric o alphanumeric)

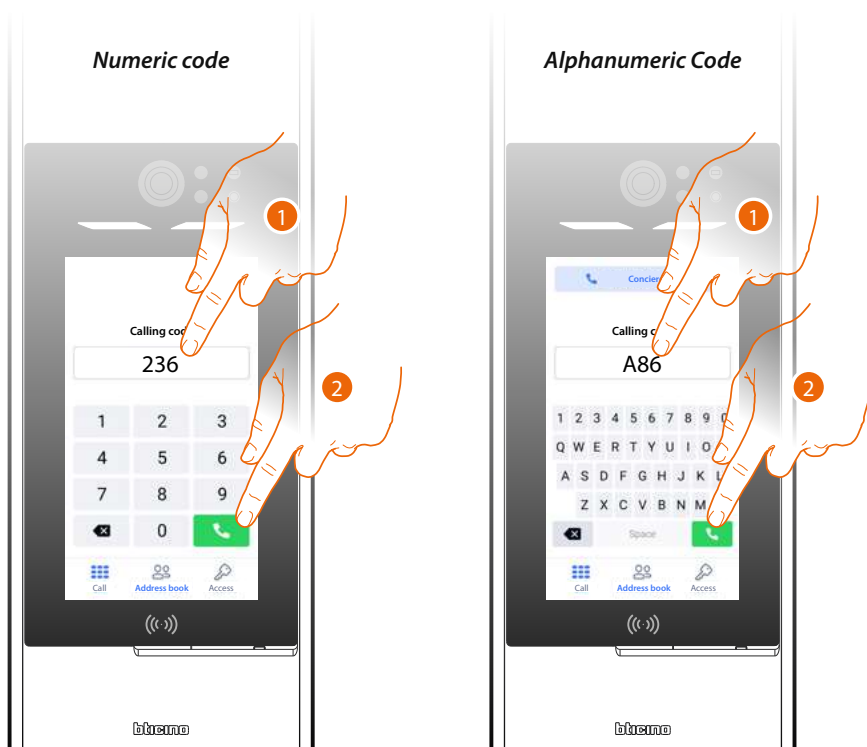

1. Enter the numeric or alphanumeric code which corresponds to the resident to be called.
2. Touch to make the call.

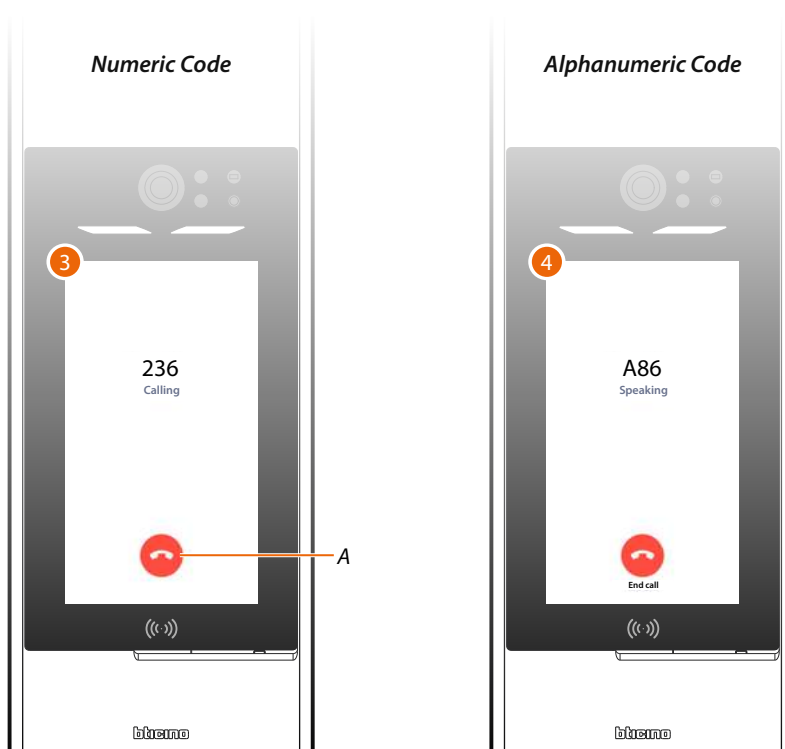

3. The call is in progress, touch to end if necessary (A).
4. The resident has answered.



5. The resident has opened the door lock (A).
6. The call is ended, recall (A) or exit (B).

Call an apartment using Block/Riser/Floor/Apartment

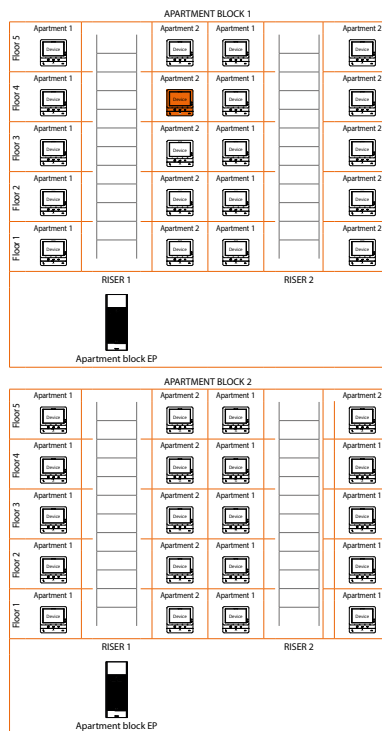
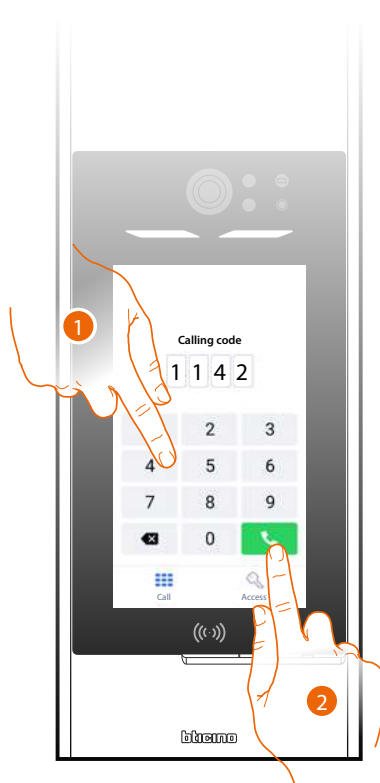

1. Enter in sequence the block, Riser, floor and apartment number of the resident to be called.
2. Touch to make the call.

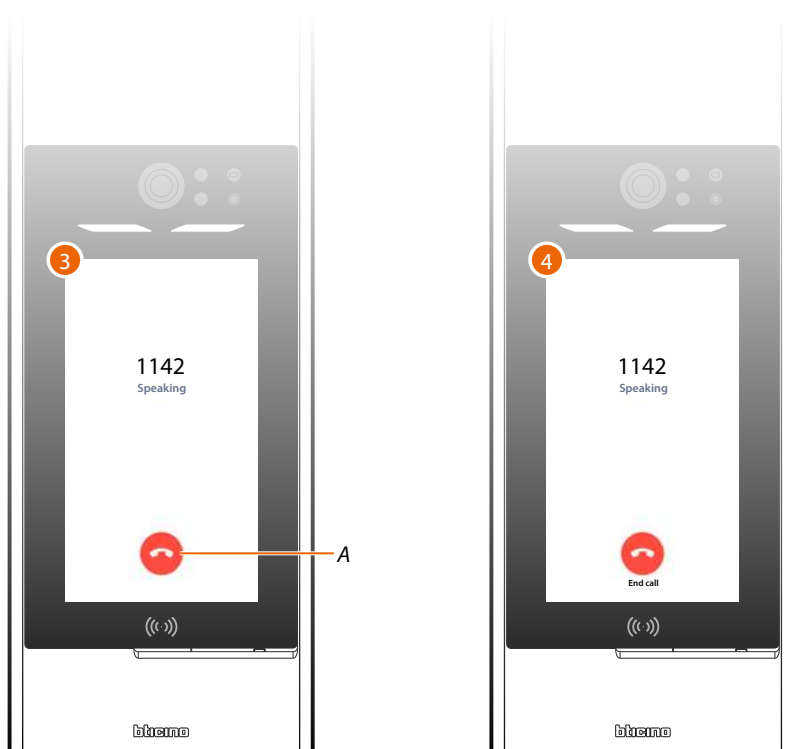

3. The call is in progress, touch to end if necessary (A).
4. The resident has answered.

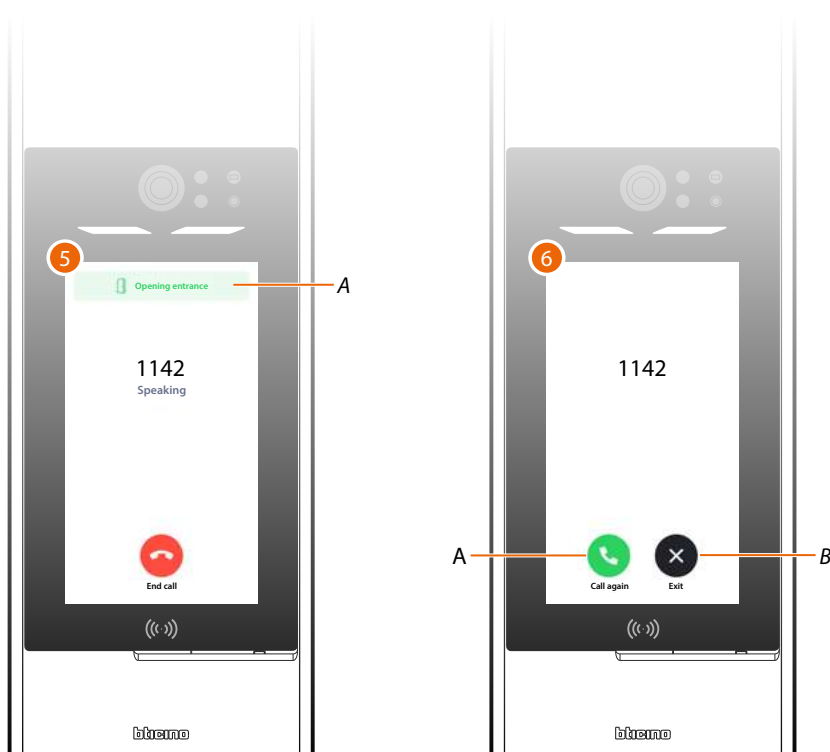

5. The resident has opened the door lock (A).
6. The call is ended, recall (A) or exit (B).

Call the guard station

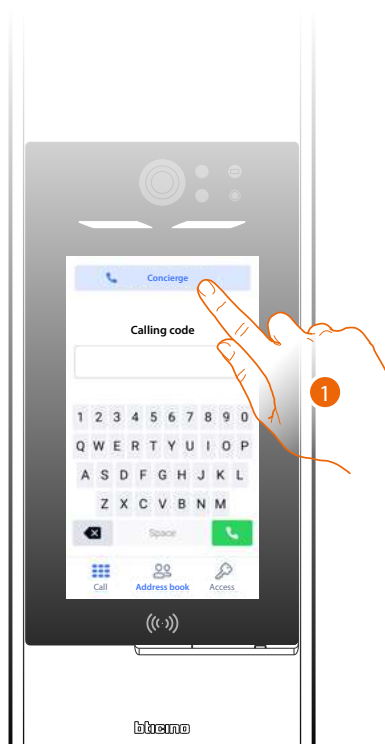

1. Touch to the call the guard station.

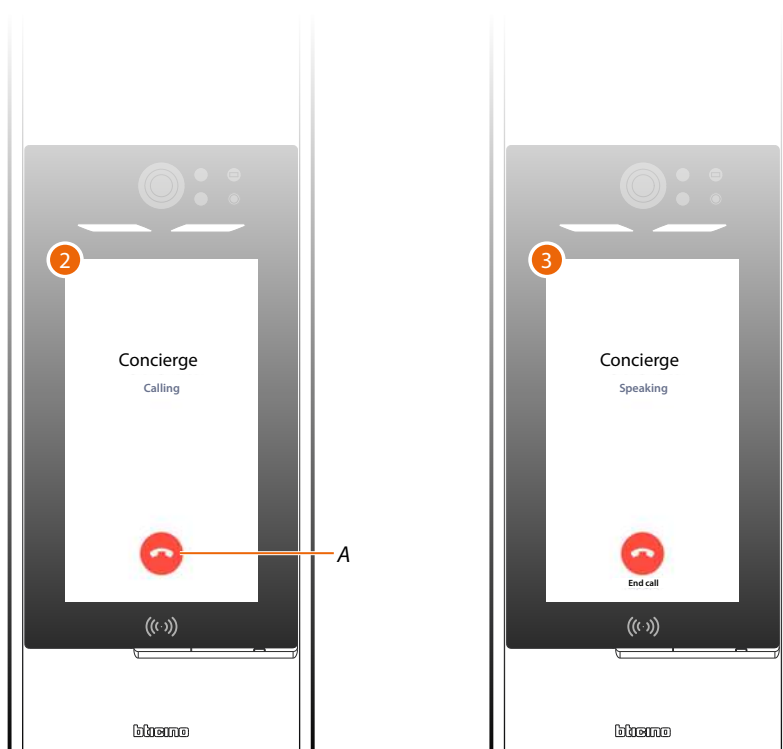

2. The call is in progress, touch to end if necessary (A).
3. The resident has answered.

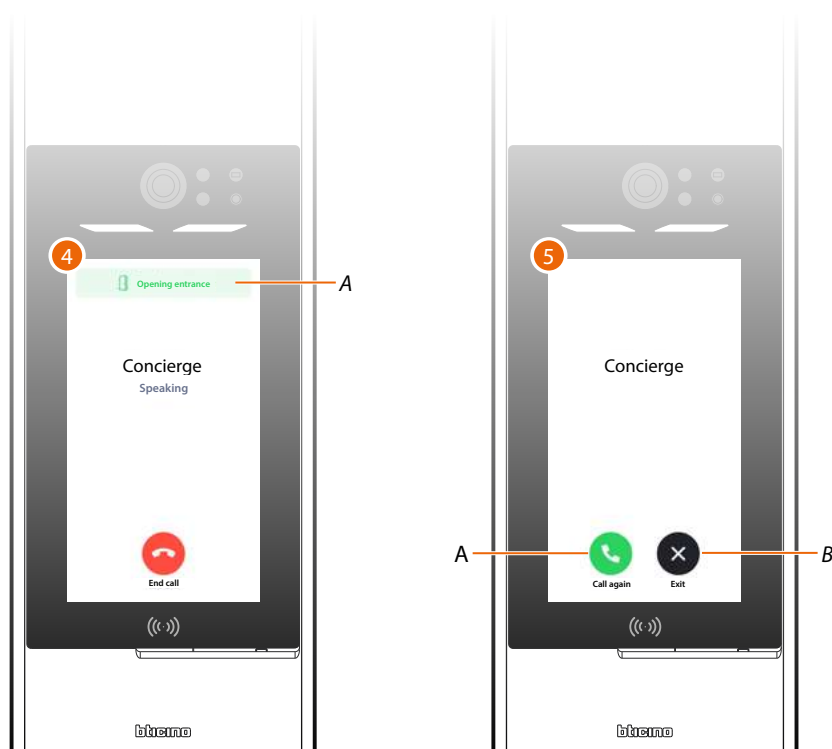

4. The resident has opened the door lock (A).
5. The call is ended, recall (A) or exit (B).

Access using a code

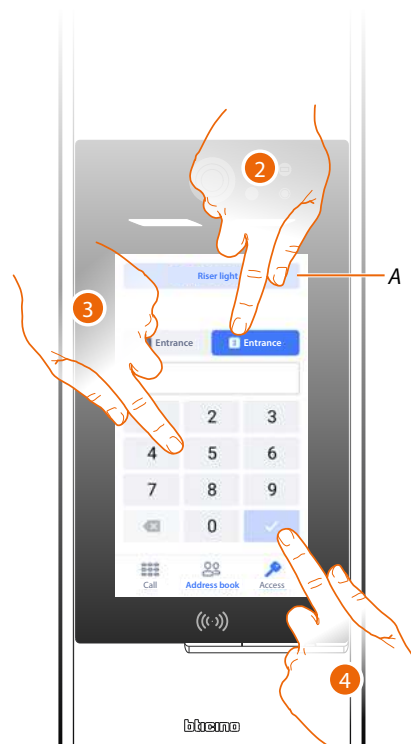
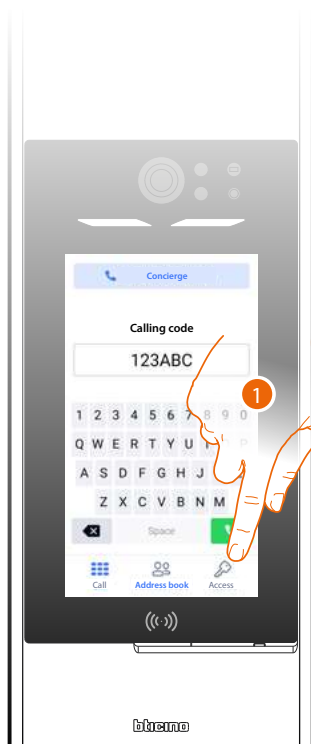

1. Touch to open the access page.
- A Switches the riser light on.
2. Select the entrance.
3. Enter the code to open the door lock.
4. Touch to confirm.

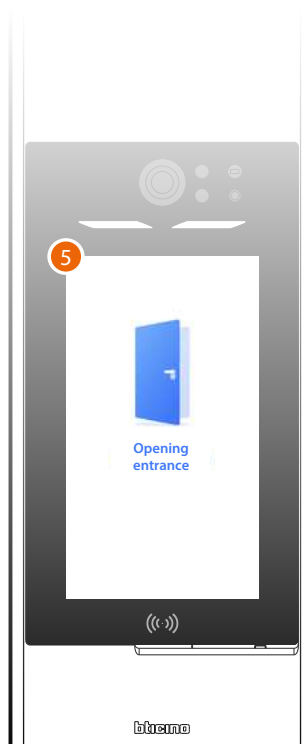

5. The entrance is open.

Access using a Badge

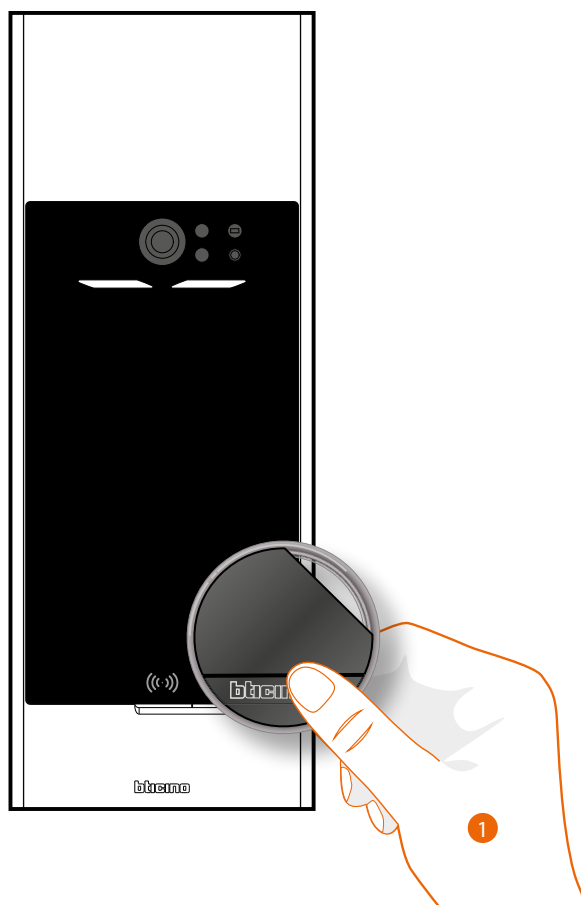

1. Place the badge in front of the EP in correspondence with the RFID reader.

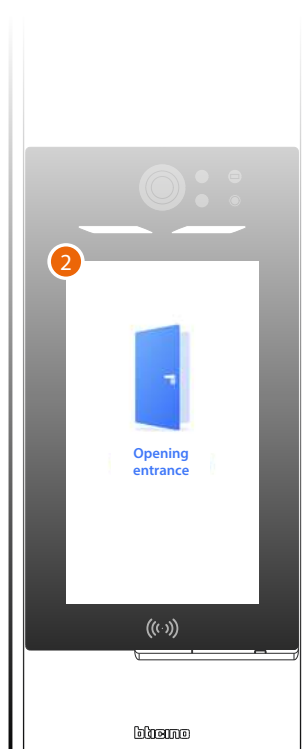

2. The entrance is open.

Quick configuration guide

Attention: the following procedure describes the minimum steps for an initial configuration of the Linea 5000.

However, we recommend that you improve your knowledge of the system by reading the entire manual.

The steps for the correct programming of the system using Home+Project are as follows:

AT THE OFFICE	ON THE SYSTEM	
		Step 1 Open Home + Project and create an account
		Step 2 Create a project
		Step 3 Customise the Contact
		Step 4 Create a badge
		Step 5 Create an access code
		Step 6 Configure the guard station
		Step 7 Create additional services
		Step 8 Install the devices
		Step 9 Configure the parameters and associate the devices to the entrances
		Step 10 Configure the network
		Step 11 Download the device updates
		Step 12 Install the device updates
		Step 13 Share the system
		Step 14 Invite the residents
		Step 15 Synchronise the changes

NOTE: some steps can be performed either in the office or on the system itself, depending on needs.

Download the Home+Project app

To be able to configure the system so that the user can use all the functions that the MyHOME system puts at your disposal, first of all download the app from the Stores (for iOS® smartphone and tablet from app Store, for Android® smartphone and tablet from Play Store).



1. On your Smartphone run the app to read the QR codes and then frame the QR Code, or search for the Home+Project app in the stores.



Account registration on the installer cloud

You must first register to be able to use the Home+Project app.
After opening the app follow the registration instructions:

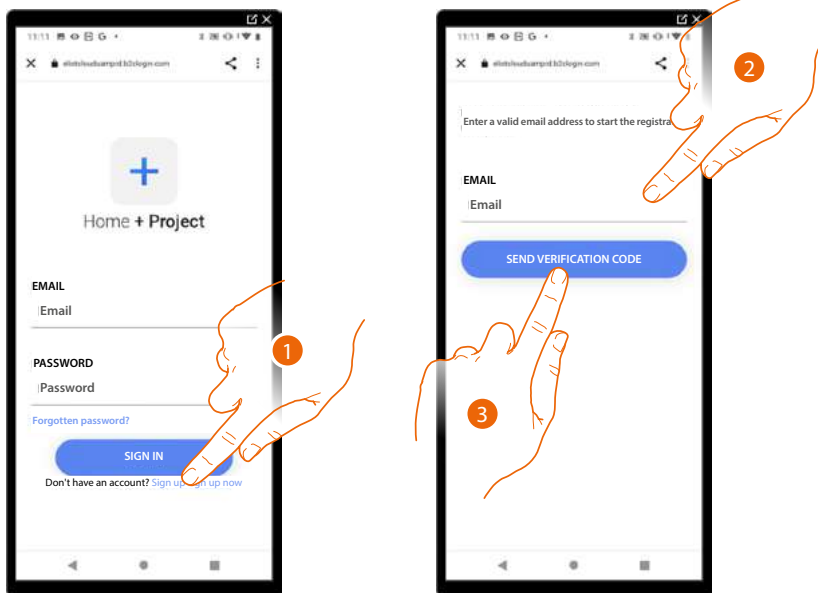

1. Touch to register and create an account.
2. Enter the email address where the system can send a verification code.
3. Touch to confirm the forwarding of the verification code.

After confirming, the system will send the data (verification code) to the email address indicated by you in the registration phase for the first access.

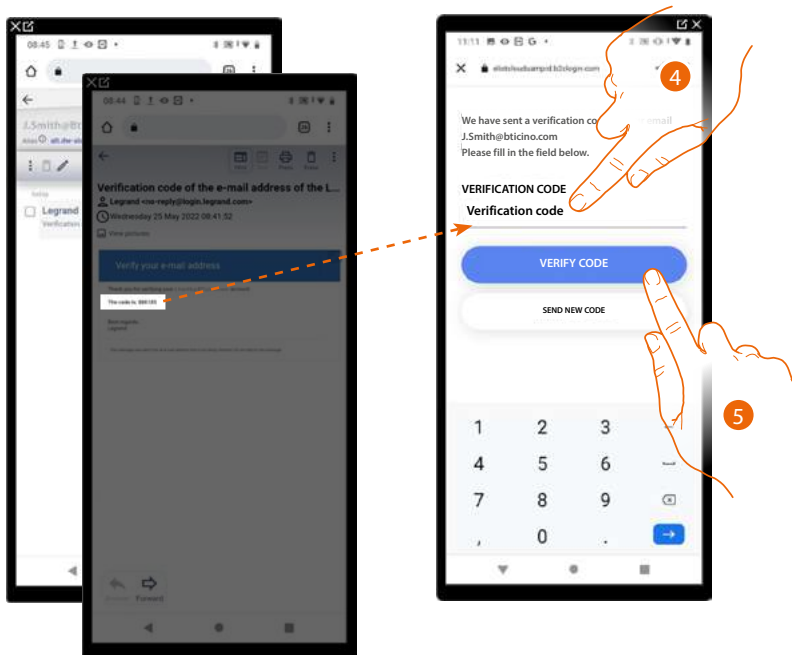

4. Enter the verification code received by e-mail.
5. Touch to confirm.

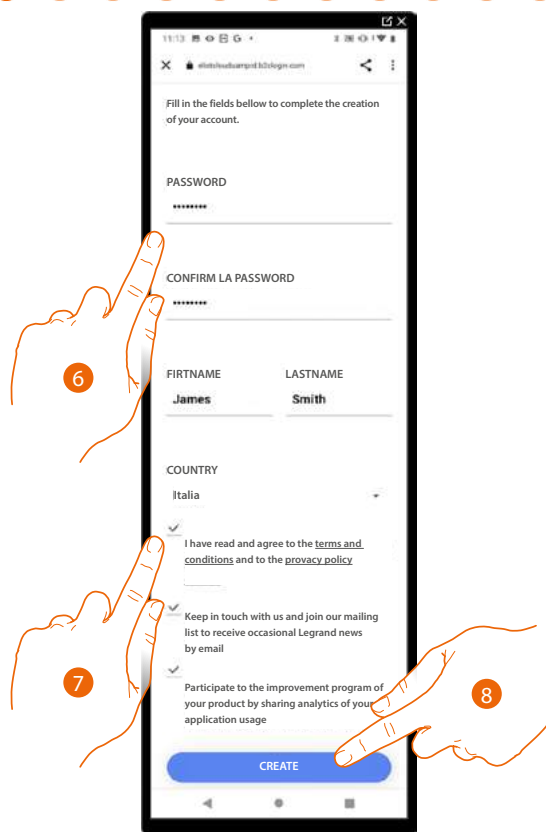

6. Enter a password and fill the fields with your details.
7. Tick to accept the terms and conditions of use laid down in the associated text (obligatory).
8. Touch to continue.

The account has been created successfully. Authentication is now **possible**.

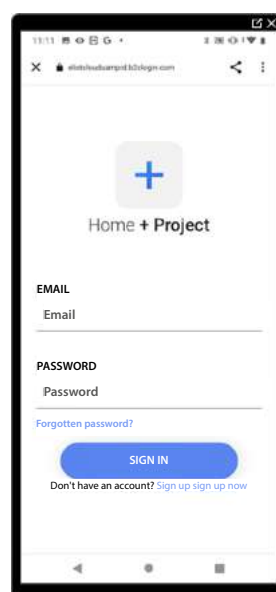

Forgotten password

When you have forgotten the password:

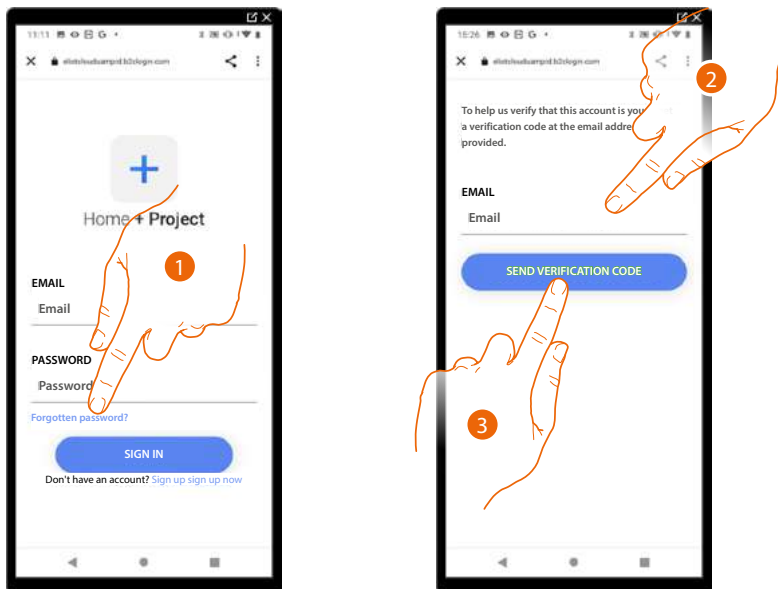

1. Touch to activate the password recovery procedure.
2. Enter the email address where the system can send a verification code.
3. Touch to confirm the forwarding of the verification code.

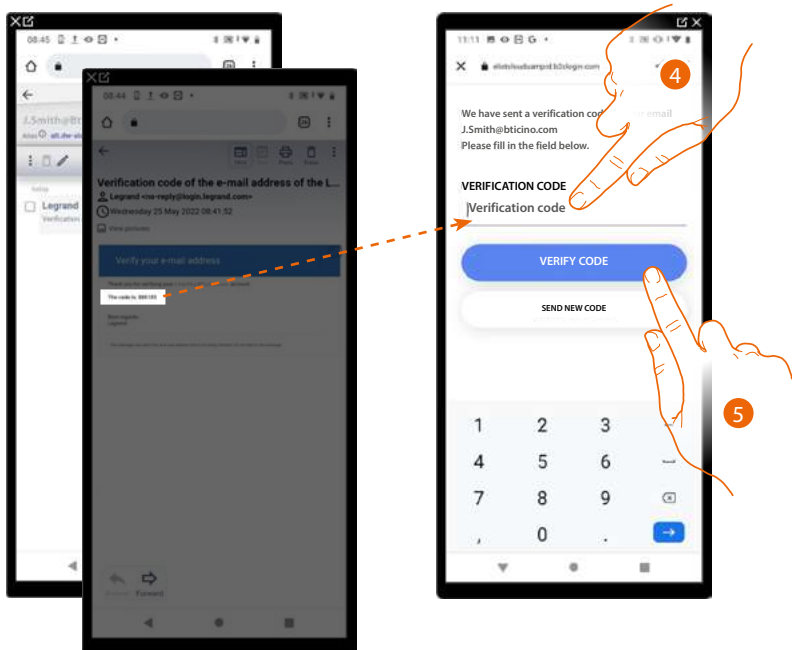

4. Enter the verification code received by e-mail.
5. Touch to verify the code.

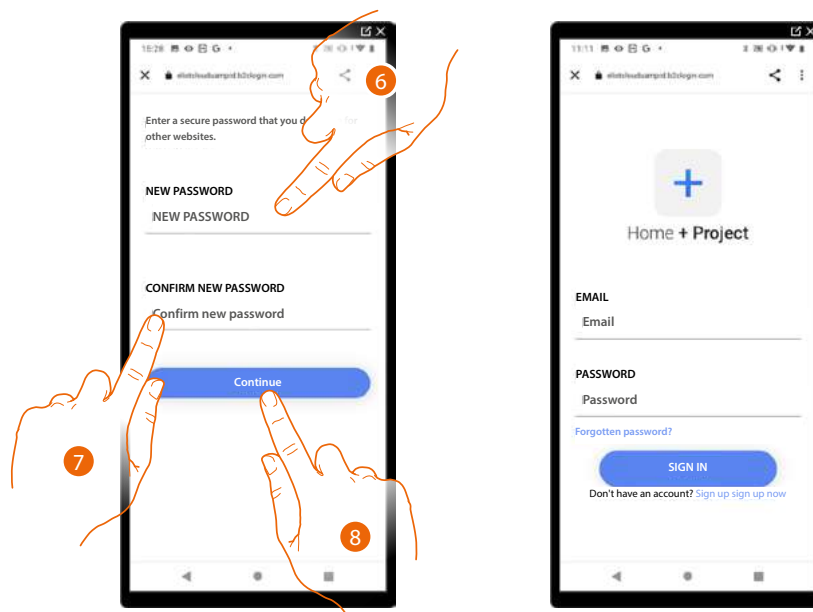

6. Enter the new password.
For security reasons enter a new password with these features:
 - minimum length 8 characters;
 - must contain at least one letter and one number;
 - it must be different from the last 5 passwords used.
7. Enter the password again.
8. Touch to confirm. The Home Page will be displayed so that the authentication procedure can be completed.

Authentication

After registering with the portal, you can authenticate by entering email and password.

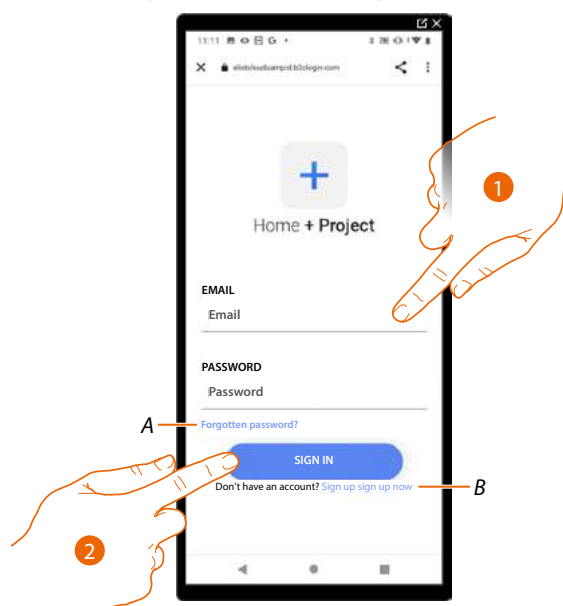

- A Touch to start the **password recovery** procedure.
- B Touch to **create a new account**.
1. Enter email and password.
2. Touch to access, the **App Home Page** appears.

App Home Page

In this page, it is possible to search, view and manage all the available systems, as well as create new ones.

You can also access some settings related to the Home+Project app and update the firmware of the devices.

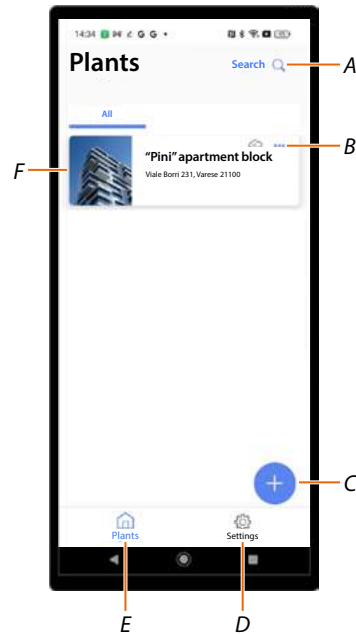

- A Opens the page that allows to search for systems by name.
- B Opens the [system management page](#) (management of guests and users and system deletion).
- C Starts the procedure for [the creation of a new system](#).
- D Opens the [App settings](#) page.
- E Opens the [App Home Page App](#).
- F Managed systems. Touch the system to open the [system Home Page](#).



System creation and first configuration

The procedure for creating the system is different depending on the type of call you want to configure in the system.

- [Call using the Address book.](#)
- [Call using the Code or the code plus Address book.](#)
- [Call using the Block/Riser/Floor/Apartment sequence.](#)

For the differences between the various call types, see [Fundamental concepts](#).

Configuration in Address Book call mode

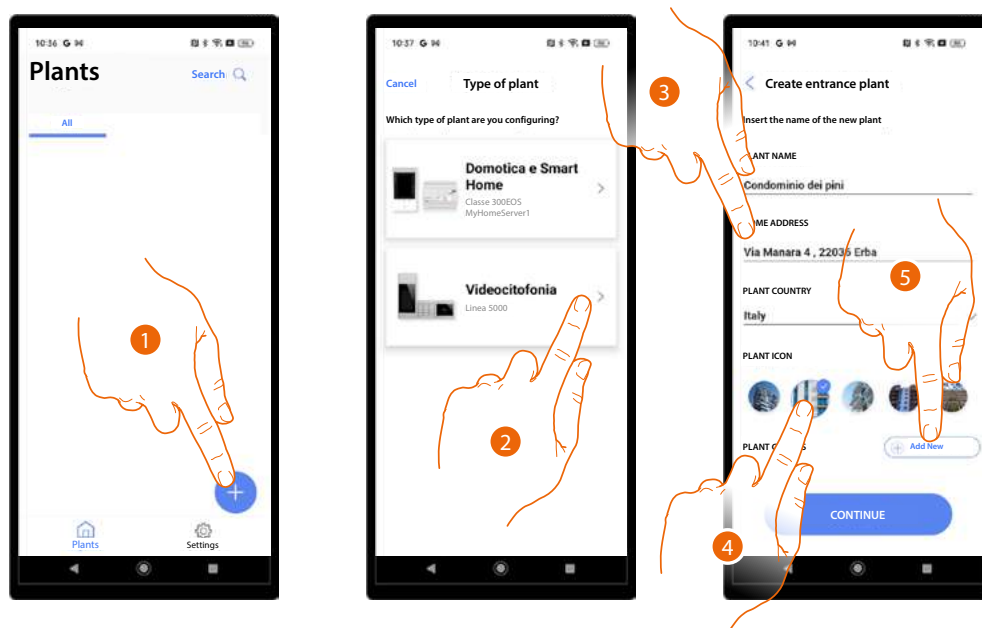

1. Touch to create a system.
2. Touch to select the type of Video door entry system.
3. Enter the system details.
4. Select an icon for the system.
5. Touch to assign to a system group or create a new one.

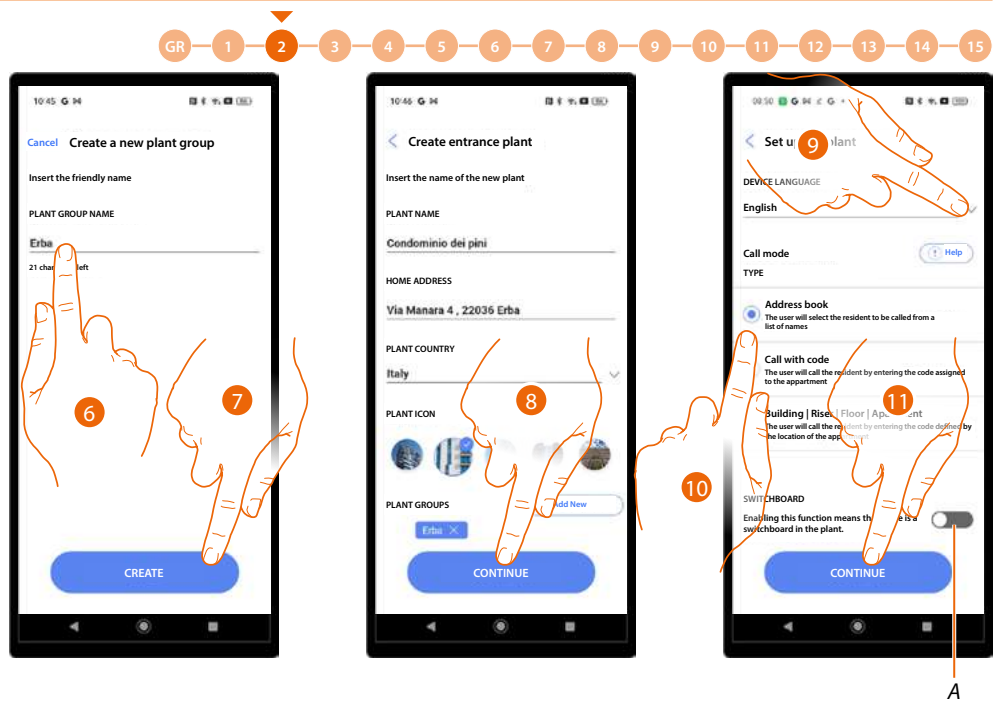

- 6. Enter a name for the system group.
- 7. Touch to create the group.
- 8. Touch to continue.
- 9. Select the EP language.
- 10. Select the Address Book call mode.

A Indicates the presence of a guard station in the system.

- 11. Touch to continue.

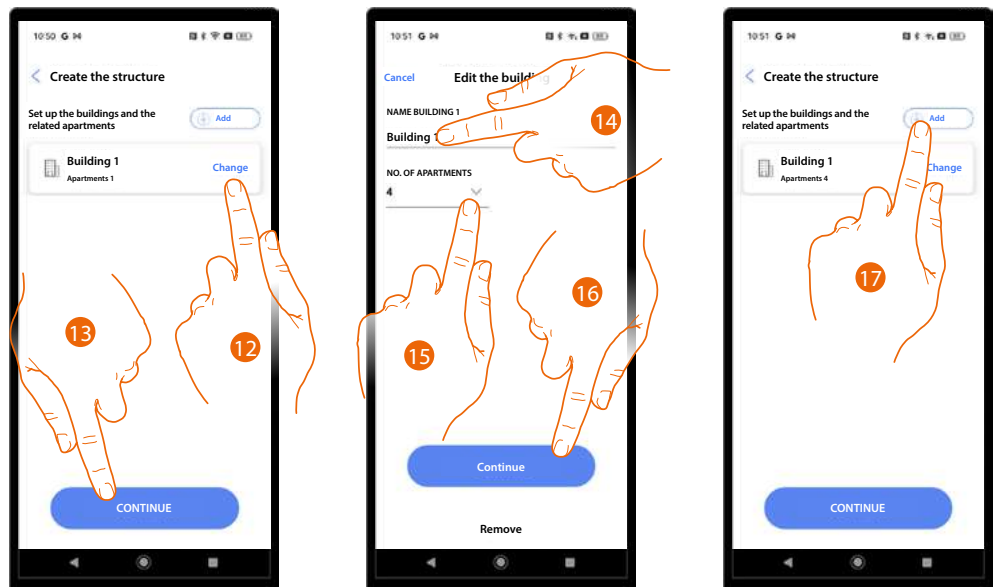

- 12. By default, the system creates 1 building with 1 apartment; touch to change.
- 13. Touch to continue.
- 14. Modify the building name.
- 15. Modify the apartment name.
- 16. Touch to continue.
- 17. Other buildings and apartments can be added in the same way; touch to do so.

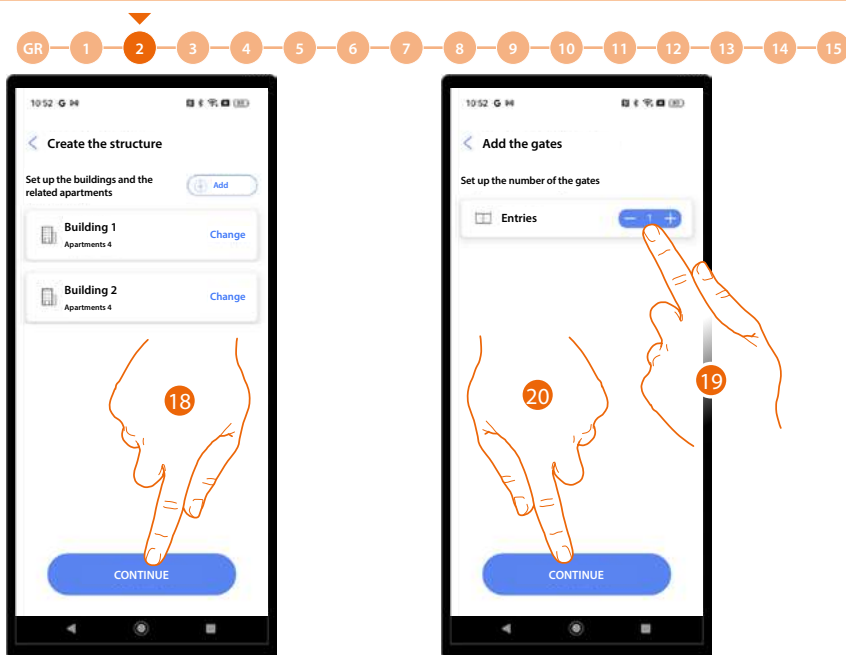

18. Touch to continue.
19. Touch to define the project entrances.
20. Touch to continue.

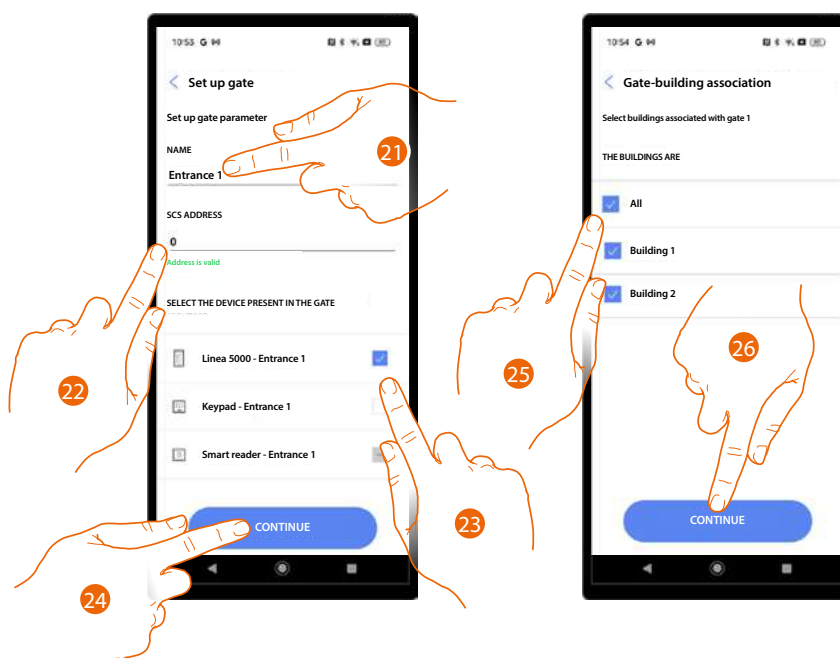

21. Touch to modify the entrance name.
22. Touch to configure the SCS address of the device associated with this entrance
23. Select the associated device among:
 - EP
 - Keypad
 - Smart reader

NOTE: multiple devices can only be associated to the same entrance using the EP and the keypad

24. Touch to continue.
25. Select the buildings (with their apartments) to which this entrance is associated.
26. Touch to continue.

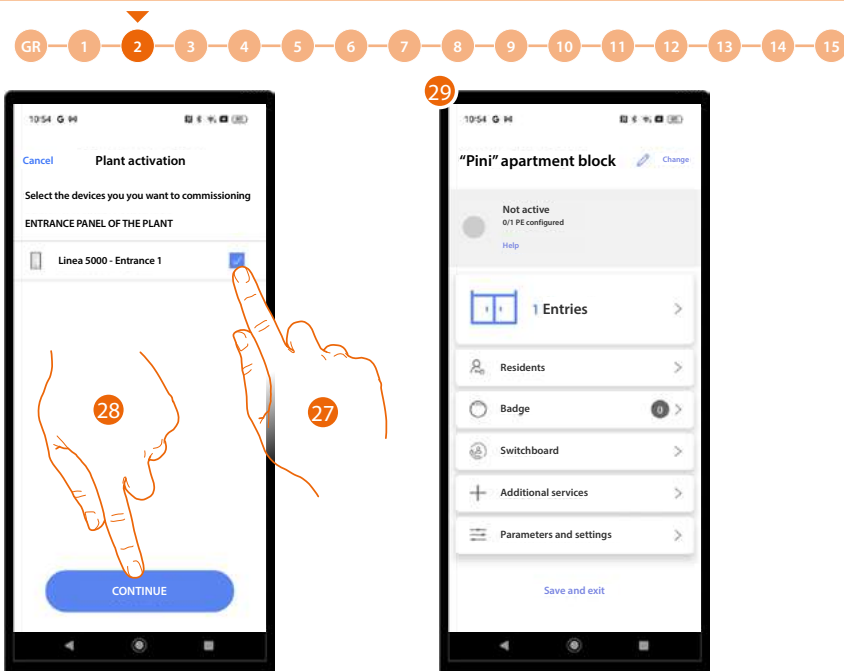

27. Touch to select the devices that you will later activate with the [appropriate procedure](#).
If you decide not to select this option for one or more devices, you can do so later in the [appropriate menu](#).
28. Touch to continue.
29. The System Home Page appears, where you can complete the [procedure for connecting](#) entrances and configure the system.



Configuration in Code or Code plus Address Book call mode

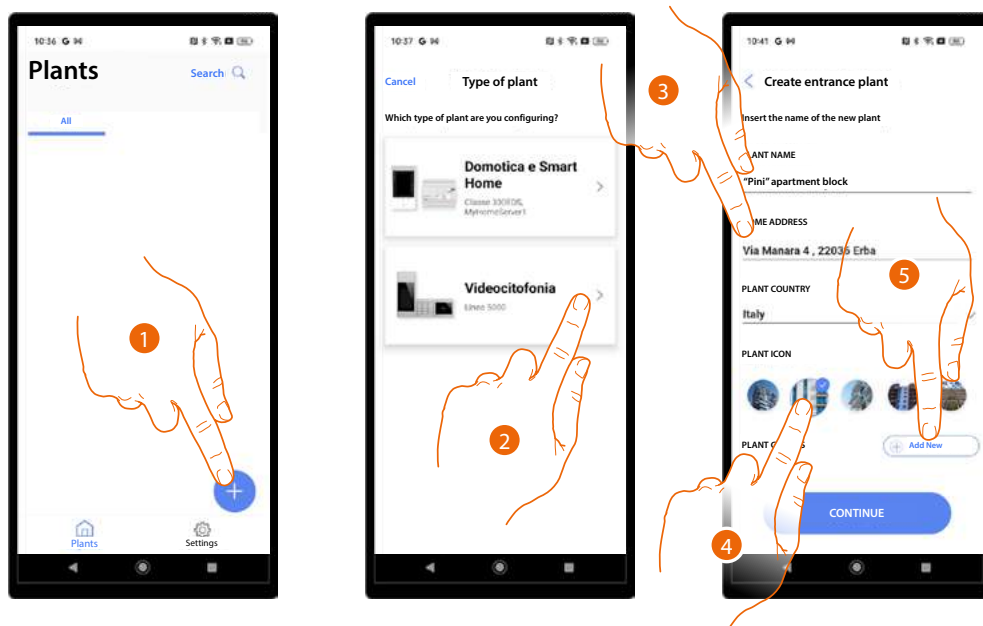

1. Touch to add and create a system.
2. Touch to select the type of Video door entry system.
3. Enter the system details.
4. Select an icon for the system.
5. Touch to assign to a system group or create a new one.

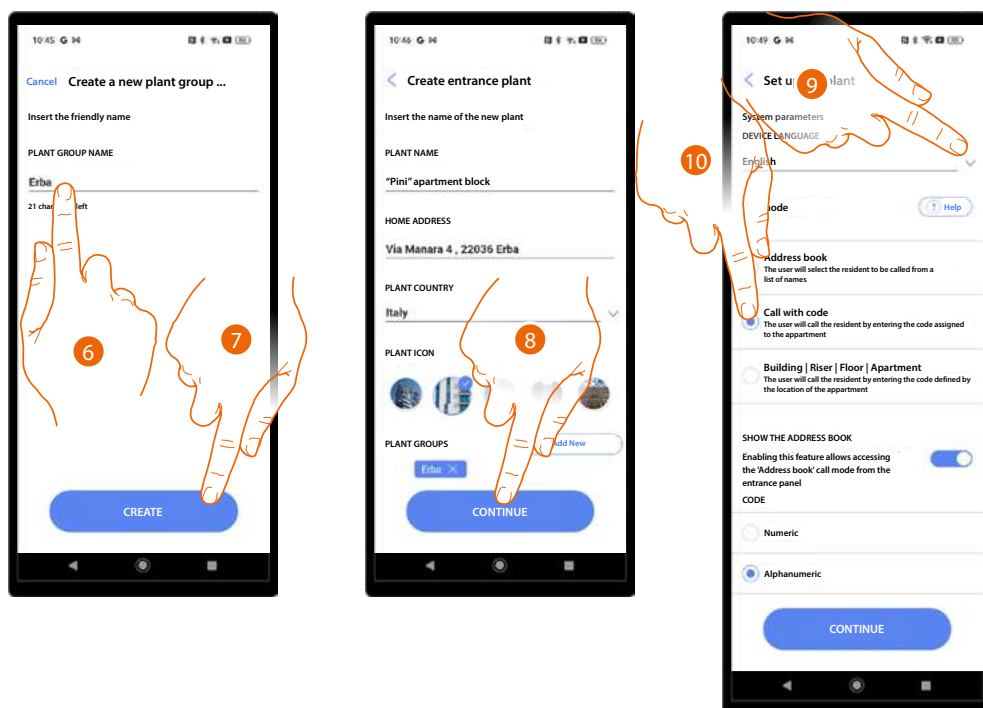

6. Enter a name for the system group.
7. Touch to create the group.
8. Touch to continue.
9. Select the EP language.
10. Select the code call mode.

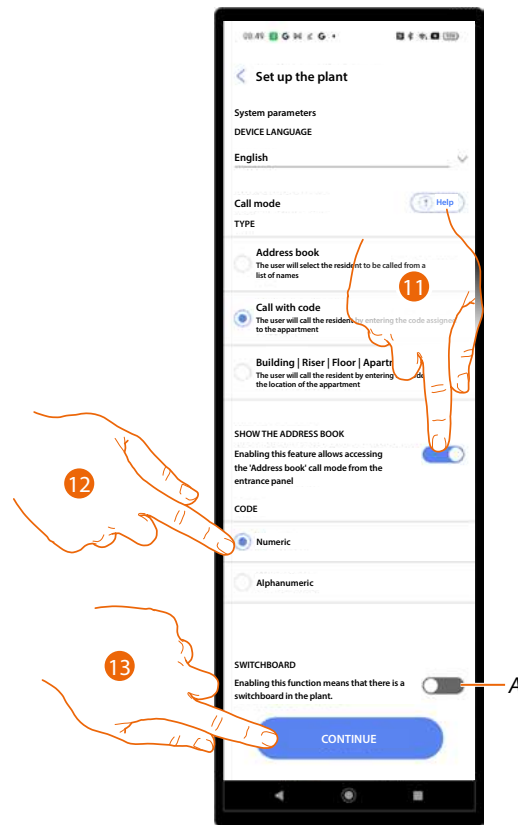

- 11 Select if you want to enable code and address book calls in the system. In this case, the address book page will also be available on the device (see [Fundamental Concepts](#) for details).
- 12 Touch to set the code as numeric (38930) or alphanumeric (1B5F6).
- A Indicates the presence of a guard station in the system.
- 13 Touch to continue.

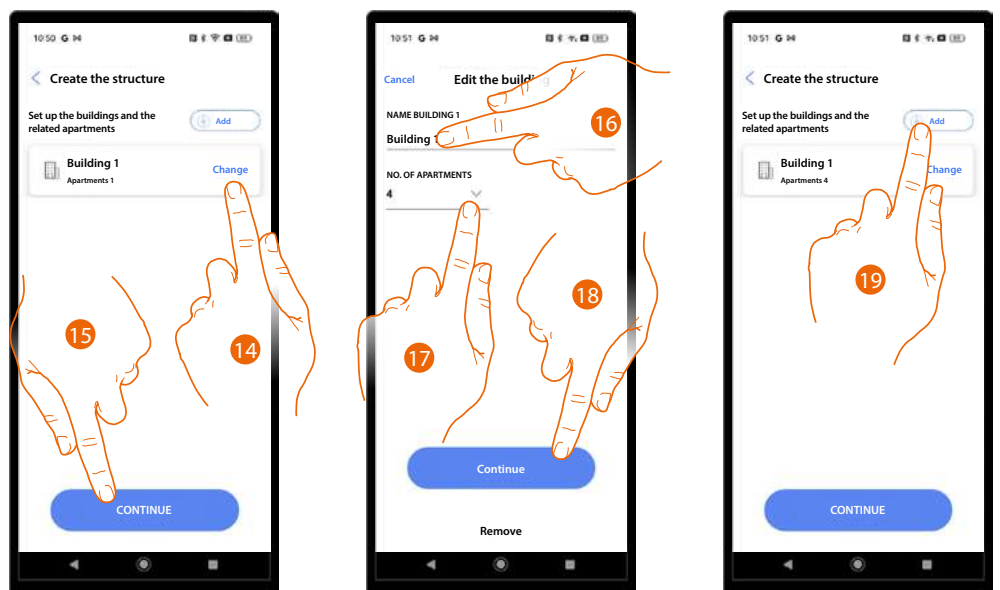

- 14. By default, the system creates 1 building with 1 apartment; touch to change.
- 15. Touch to continue.
- 16. Modify the building name.
- 17. Modify the apartment name.
- 18. Touch to continue.
- 19. Other buildings and apartments can be added in the same way; touch to do so.

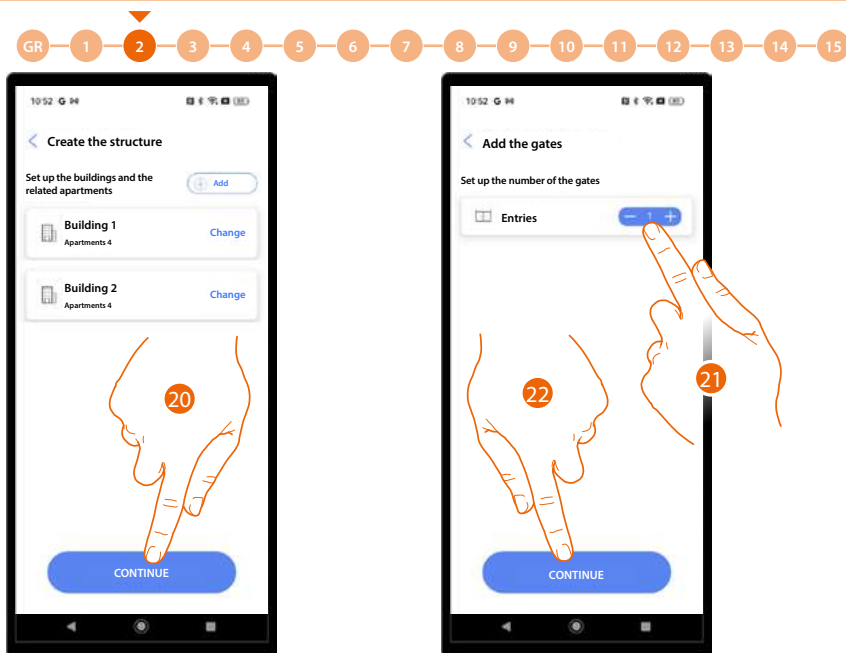

- 20. Touch to continue.
- 21. Touch to define the project entrances.
- 22. Touch to continue.

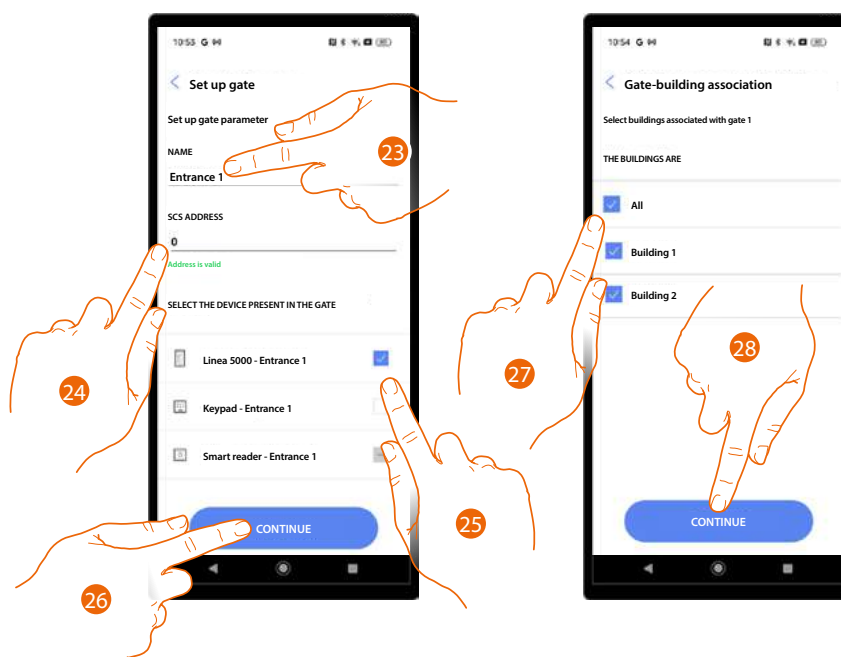

- 23. Touch to modify the entrance name.
- 24. Touch to configure the SCS address of the device associated with this entrance.
- 25. Select the associated device among:
 - EP
 - Keypad
 - Smart reader

NOTE: Multiple devices can only be associated to the same entrance using the EP and the keypad.

- 26. Touch to continue.
- 27. Select the buildings (with their apartments) to which this entrance is associated.
- 28. Touch to continue.

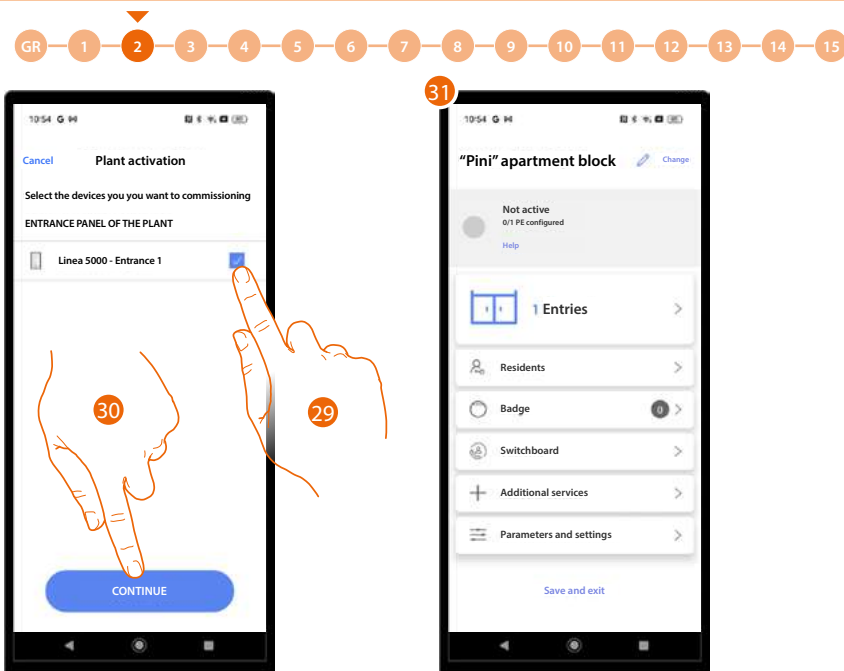

29. Touch to select the devices that you will later activate with the [appropriate procedure](#). If you decide not to select this option for one or more devices, you can do so later in the [appropriate menu](#).
30. Touch to continue.
31. The System Home Page appears, where you can complete the [procedure for connecting](#) entrances and configure the system.



Configuration in Block/Riser/Floor/Apartment call mode.

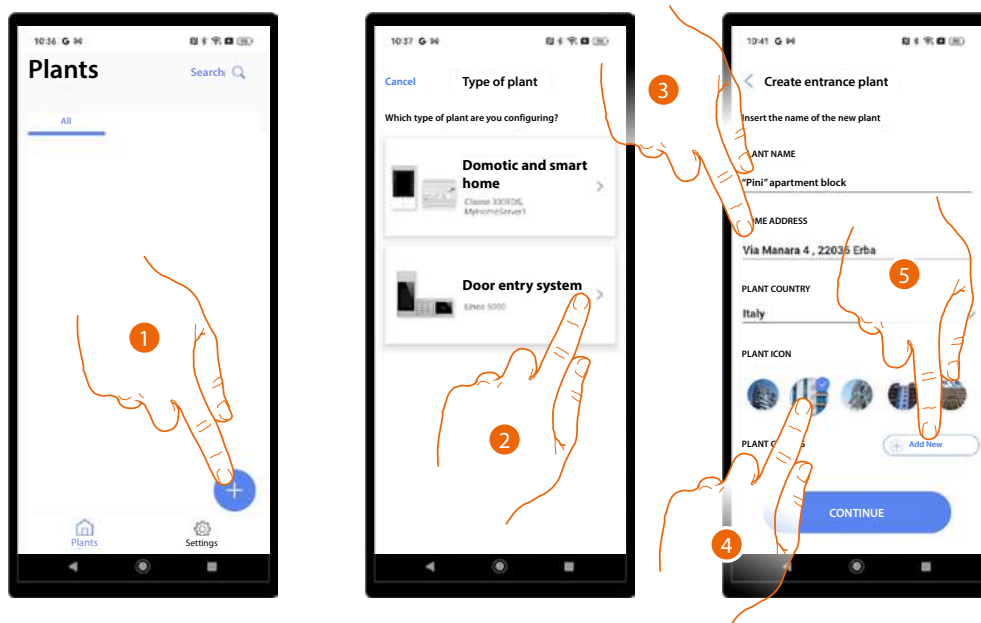

1. Touch to add and create a system.
2. Touch to select the type of Video door entry system.
3. Enter the system details.
4. Select an icon for the system.
5. Touch to assign to a system group or create a new one.

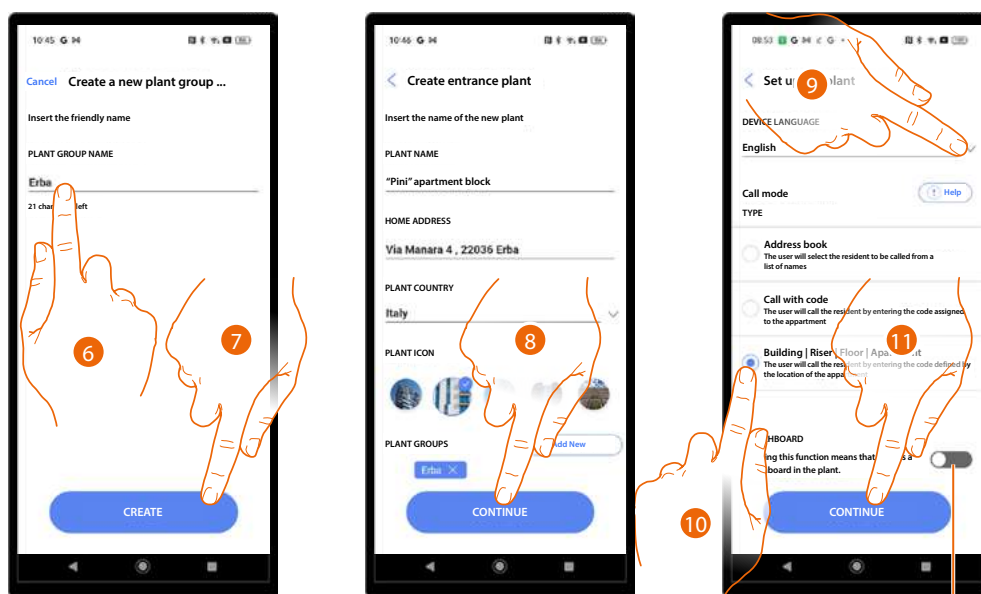

6. Enter a name for the system group.
7. Touch to create the group.
8. Touch to continue.
9. Select the EP language.
10. Select the BSFA call mode.

A Indicates the presence of a guard station in the system.

11. Touch to continue.

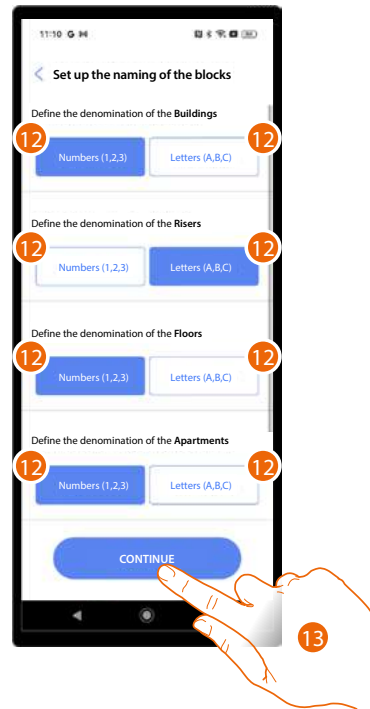

12. Define whether to use numbers or letters for the block names (buildings/Risers/floors/apartments).

13. Touch to continue.

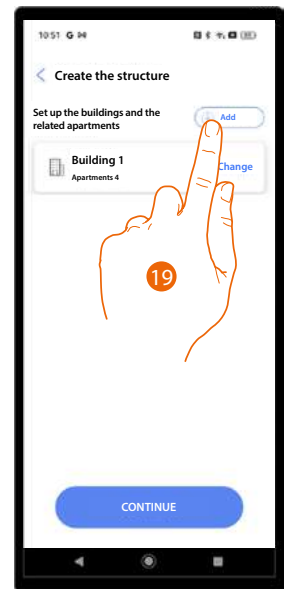
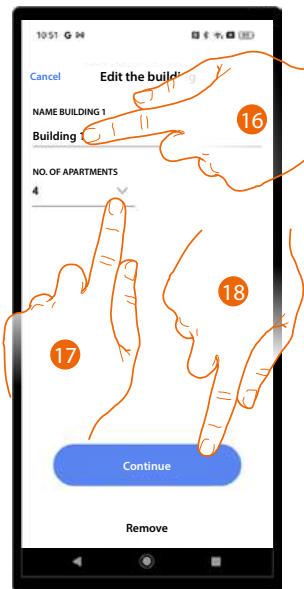

14. By default, the system creates 1 building with 1 apartment; touch to change.

15. Touch to continue.

16. Modify the building name.

17. Modify the apartment name.

18. Touch to continue.

19. Other buildings and apartments can be added in the same way; touch to do so.

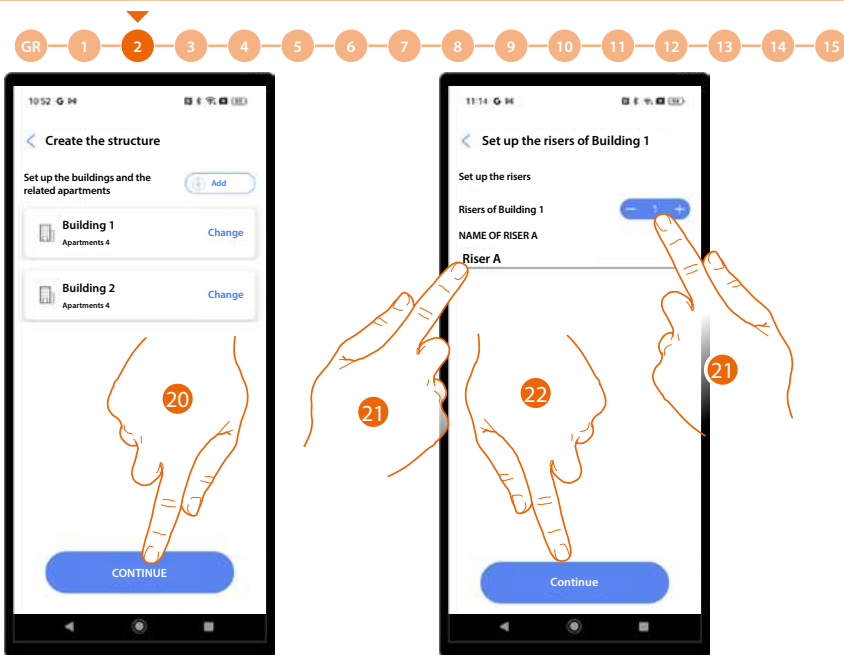

- 20. Touch to continue.
- 21. Touch to set the number and name of the Risers in the building.
- 22. Touch to continue.

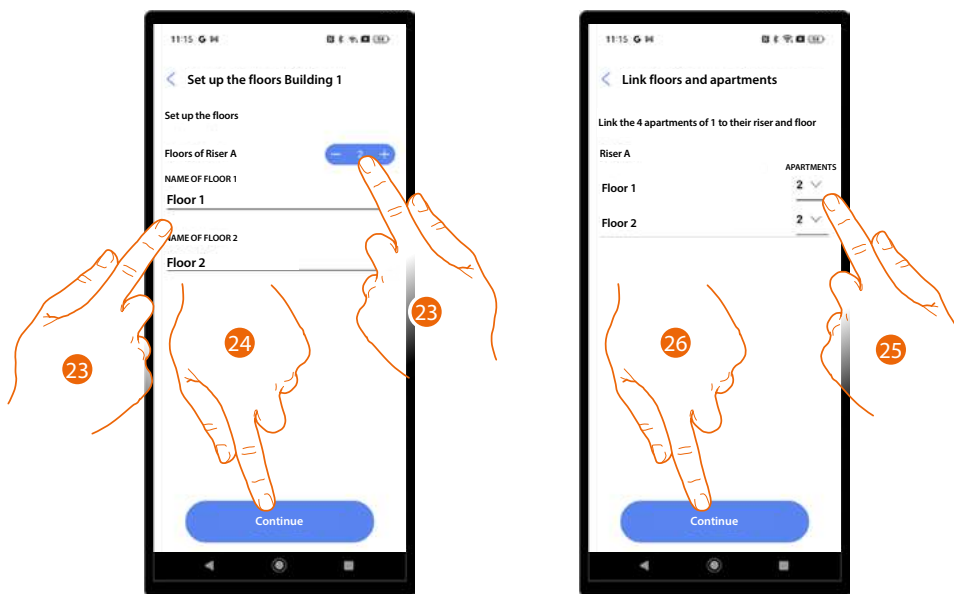

- 23. Touch to set the number and name of the floors for the riser.
- 24. Touch to continue.
- 25. Touch to set the number of apartments for each floor.
- 26. Touch to continue.

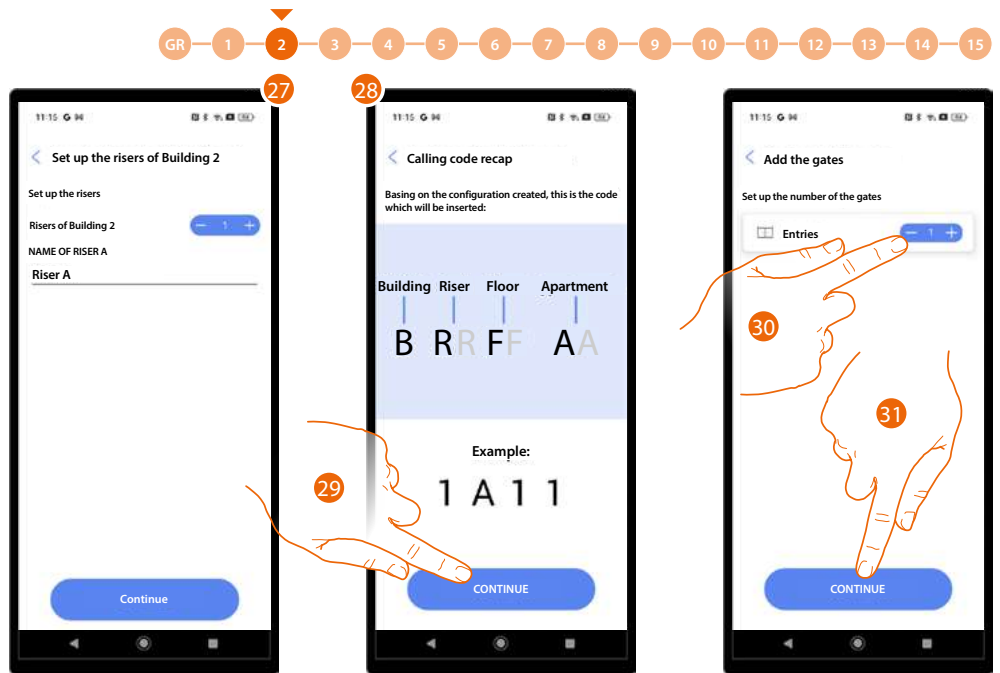

- 27. Repeat the same steps for all buildings.
- 28. When finished, a help screen will help understand the logic of the BRFA code.
- 29. Touch to continue.
- 30. Touch to define the project entrances.
- 31. Touch to continue.

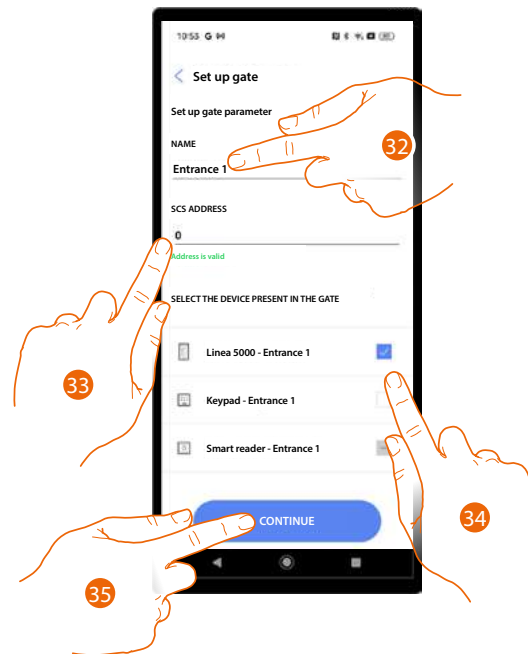

- 32. Touch to modify the entrance name.
- 33. Touch to configure the SCS address of the device associated with this entrance.
- 34. Select the associated device among:
 - EP
 - Keypad
 - Smart reader
- 35. Touch to continue.

NOTE: Multiple devices can only be associated to the same entrance using the EP and the keypad.

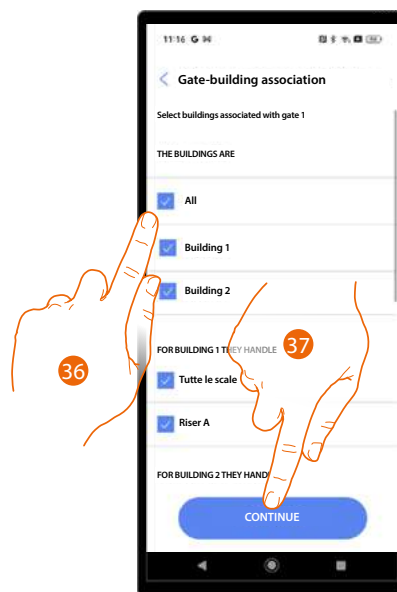

36. Select the buildings (with their apartments) to which this entrance is associated.
37. Touch to continue.

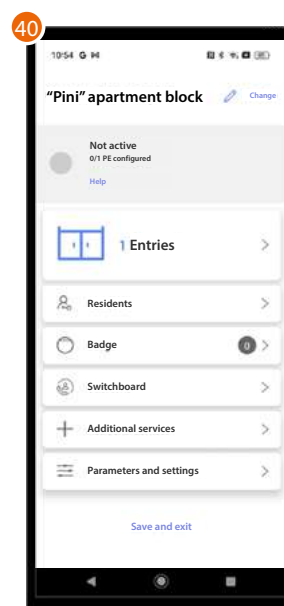
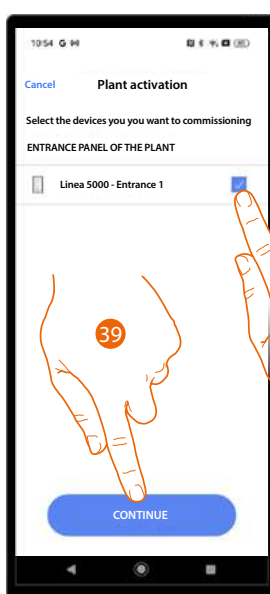

38. Touch to select the devices that you will later activate with the [appropriate procedure](#). If you decide not to select this option for one or more devices, you can do so later in the [appropriate menu](#).
39. Touch to continue.
40. The System Home Page appears, where you can complete the [pocedure for connecting](#) entrances and configure the system.

System management

This menu allows to manage your system and its connected users.

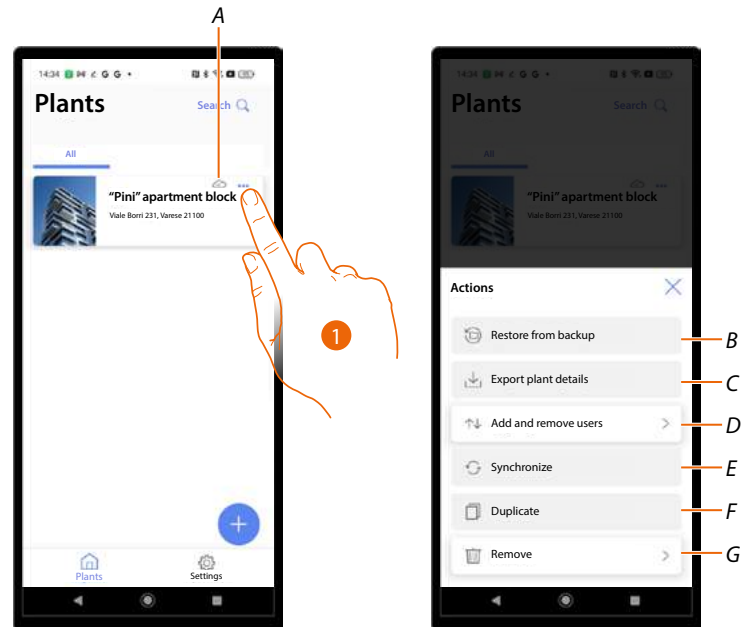

A Indicates if the system is synchronised with the cloud.

1. Touch to open the system management menu.

B Function currently not available.

C Function currently not available.

D Opens the page for managing the users with whom you have shared the management of the system.

E Function currently not available.

F Function currently not available.

G Delete the system.



System sharing

This page can be used to share the system with other users and subsequently manage them. When creating a user, the same must be assigned a role as follows:

- **Installer:** this user has access to all the functions and is the user who will follow the installation to the end, from structure to residents, to device parameters.
- **Building Manager:** this role only has access to certain functions related to residents and to the modification of certain device parameters.

After the creation of the system, a user with double role, Installer and Building Manager, is also created automatically.

For more information on the differences between the 2 roles, see [Basic Concepts](#). It is good practice to split the two roles according to the following procedure.

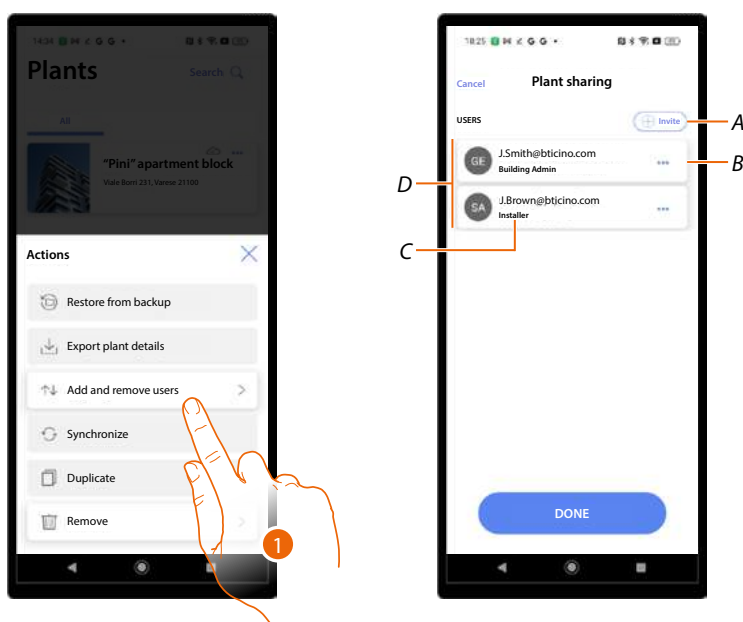

1. Touch to enter the page

A Activates the procedure for [inviting another user](#) to allow them to manage and configure your system.

B Opens the page where it is possible to [edit the role of the user](#). It is also possible to [delete the account](#).

C User role.

D Users who can manage the system.



Splitting of roles after the creation of the project

After the creation of the project, a dual role is assigned for device management.

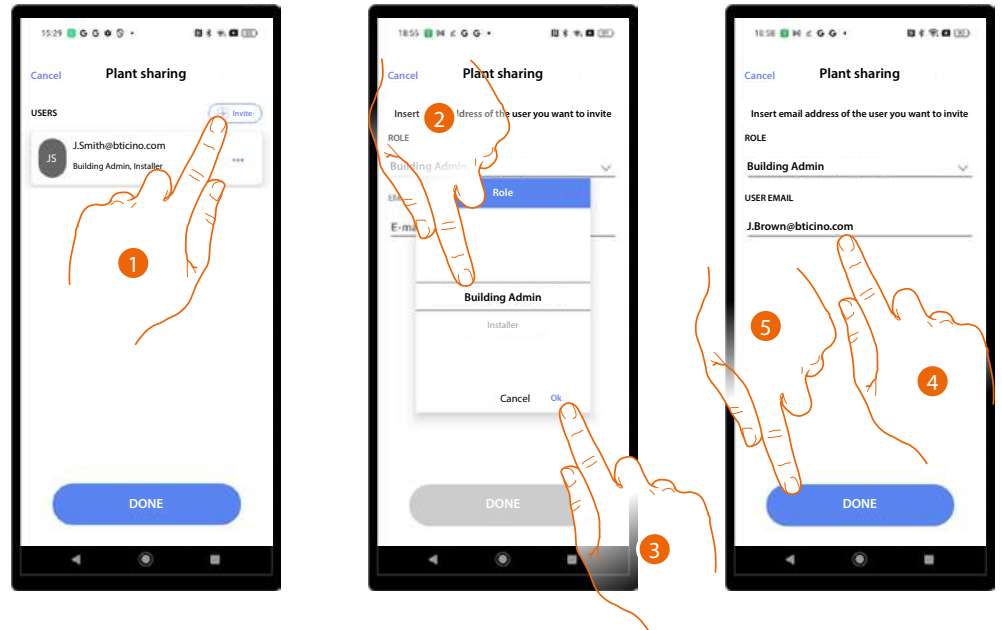

1. Touch to invite the person who will Manage the Building.
2. Select the Building Manager role.
3. Touch to confirm.
4. Enter his/her email address.
5. Touch to send the invitation.

The "Building Manager" role is then removed from the user with dual role who created the project.

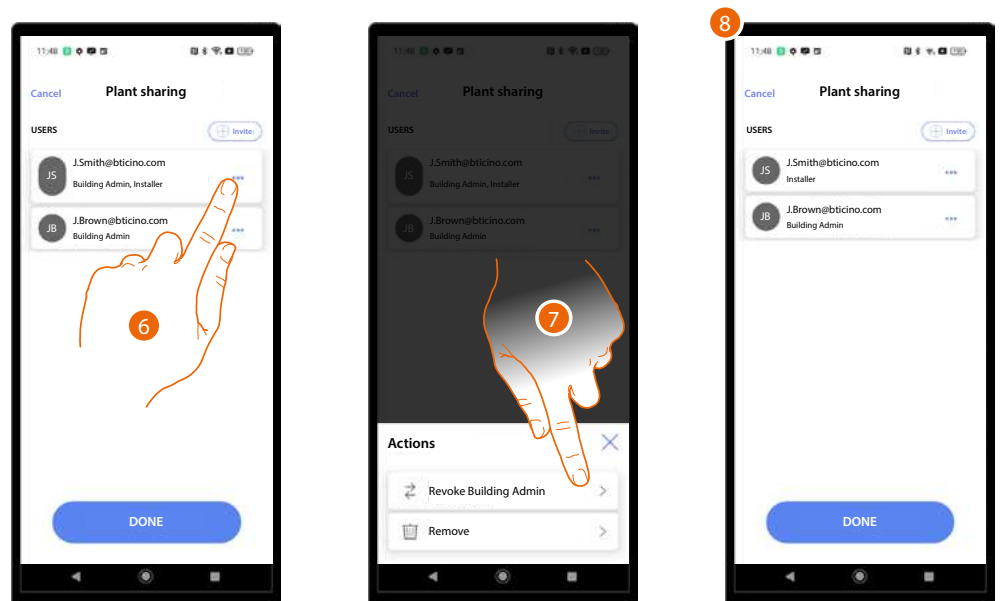

6. Touch to open the management page.
7. Touch to remove the "Building Management" role.
8. There are now two roles for the management of the project.



Invite another user

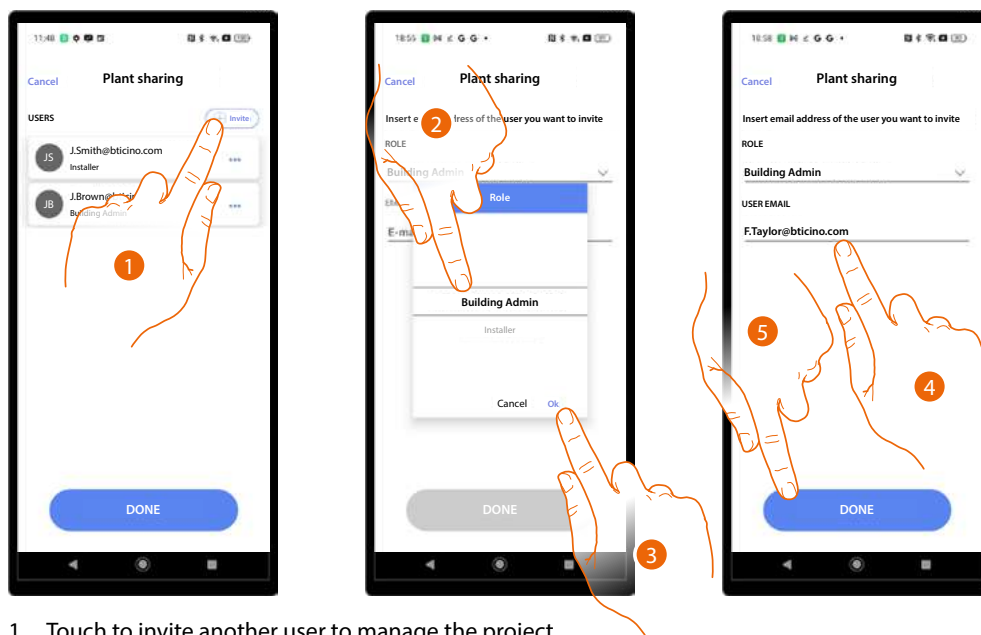

1. Touch to invite another user to manage the project.
2. Select the role.
If you are a Building Manager, you can assign to the new user the role of either Building Manager or Installer.
If you are an Installer, you can only assign the role of installer.
3. Touch to confirm.
4. Enter his/her email address.
5. Touch to send the invitation.

The new user can manage the project.

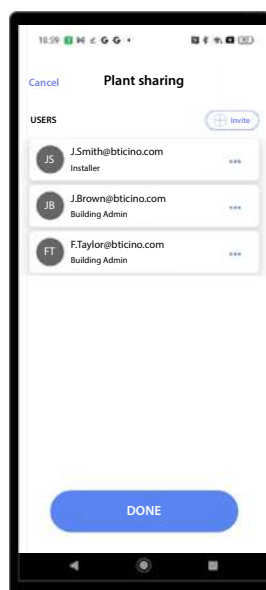



Remove user

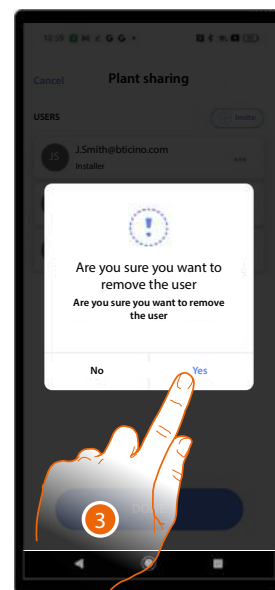
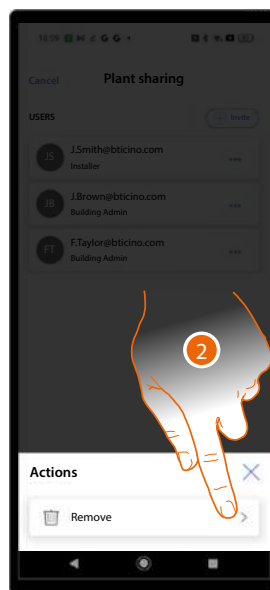
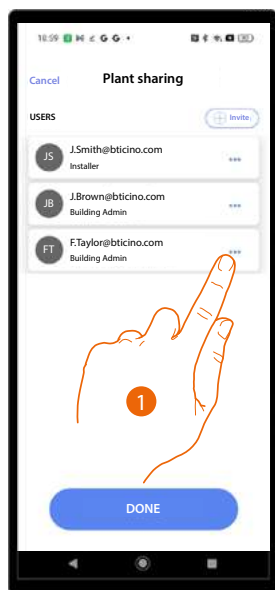

1. Touch to open the management page.
2. Touch to remove the user from management of the project.
3. Touch to confirm.

The user has been deleted.

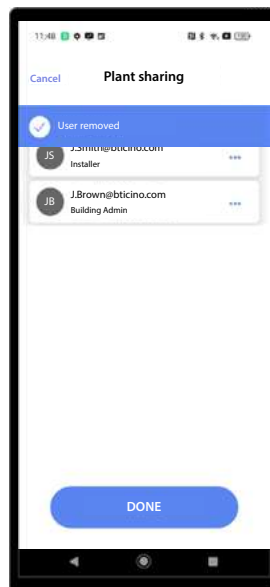

Delete the system

With this procedure, you can delete an existing system.

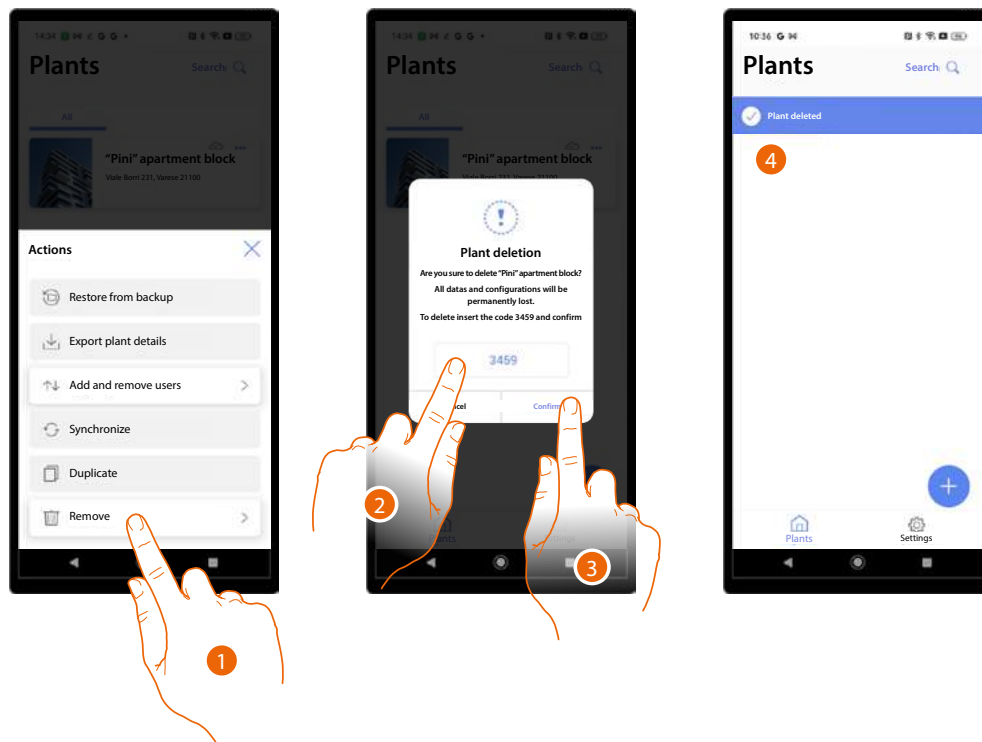

1. Touch to delete the system.
2. Enter the confirmation code that appears on the screen.
3. Touch to confirm.

ATTENTION: when the operation is confirmed, all system data and configurations will be lost.

4. The system has been deleted.

NOTE: the deleted system disappears from the owner's Home+Project app and from the Home+Project app of collaborators (if any).

App settings

In this page, it is possible to access some settings of your account and update the device firmware. It is also possible to log out from the Home+Project app.

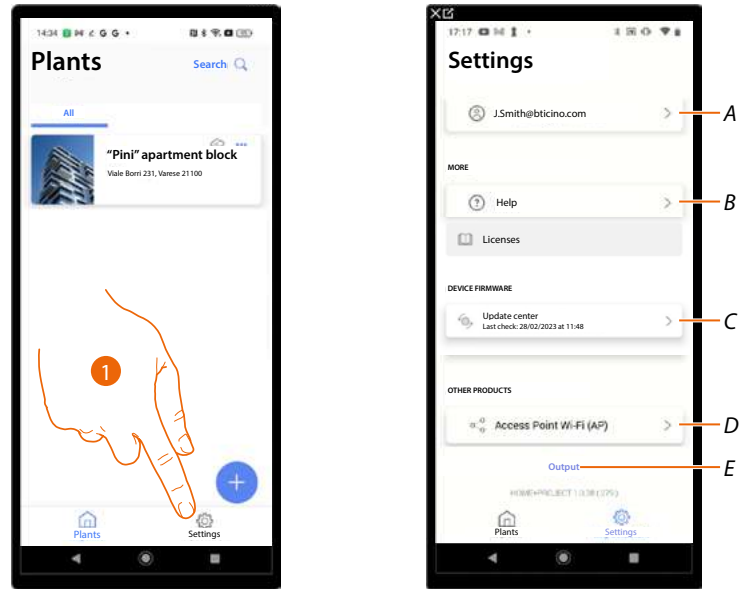

1. Touch to enter the page.
- A Opens the [account management](#) page.
- B Opens the [Help](#) page.
- C Opens the page with the device [updates](#).
- D Function not available.
- E Log out.

Account management

In this page it is possible to view and display some functions regarding your account.

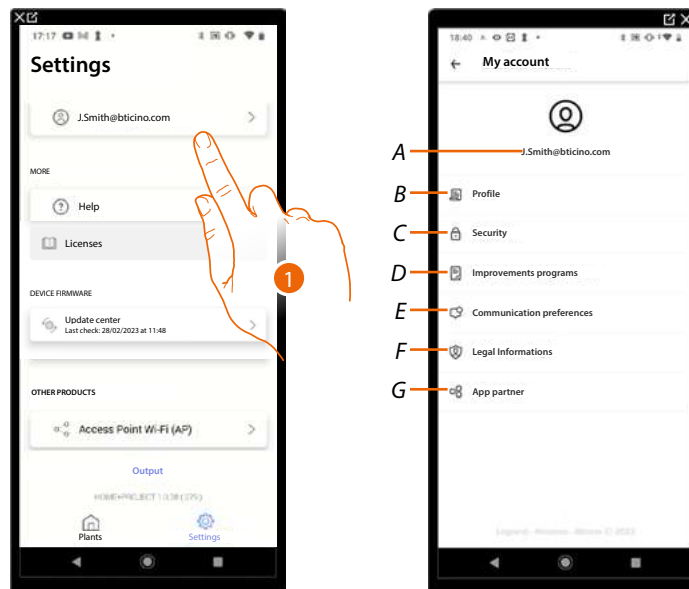

1. Touch to enter the page.
- A Account Login/Email address.
- B Display/edit your Legrand account **registration details**.
- C Edit some **parameters related to your** account security, such as password and logging out of all BTicino devices using the same account.
- D Authorise the sharing of data to help improve the product.
- E Manage your communication **authorisations** and other aspects of your personal details.
- F Display **contract terms and conditions** regarding the Legrand apps that you are using.
- G Manage **partner apps** to which your account is connected (e.g. Google Home etc.)

Profile

In this page it is possible to edit some data of the account currently managing the device, or to replace it with another registered Legrand account.

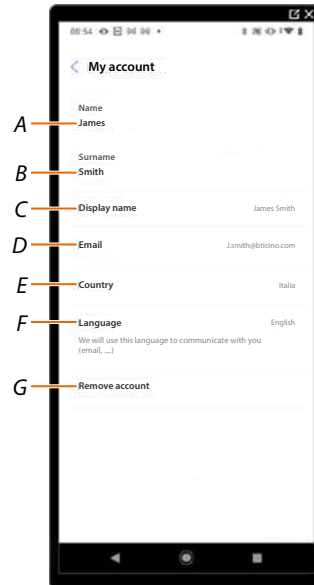

- A View/edit the name used for the account.
- B Display/edit the surname used for the account.
- C **Show/edit the name used for the account.**
- D **View/edit the device management email/account.**
- E Display the country.
- F **Display/select the language in which to receive communications.**
- G **Delete the account.**

Show name (edit name)

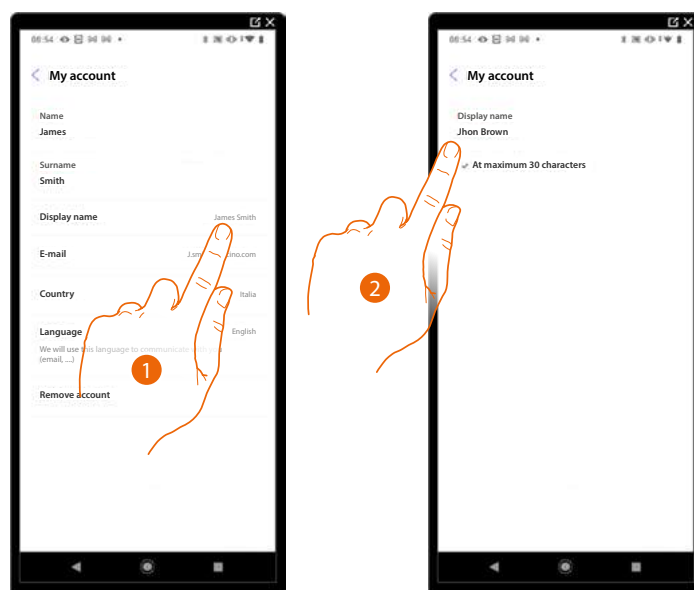

1. Touch to edit the name.
2. Enter the name that will be used in the system e-mail communications.

Email/account (change of the device management email/account)

To change the access email address:

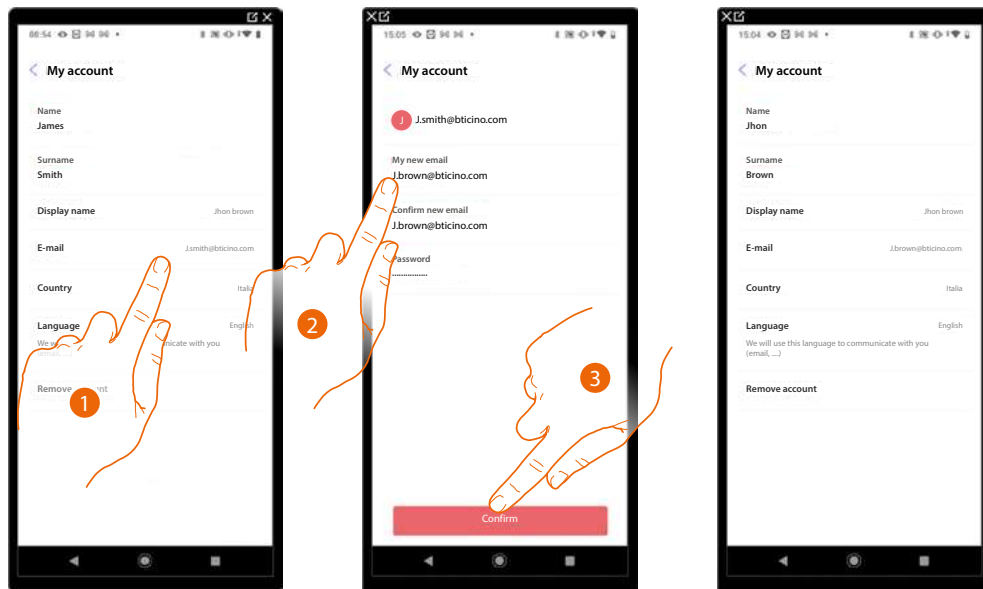

1. Touch to edit the email address.
2. Enter the login details (email and password) of the new registered Legrand account to be used to manage the device.
3. Touch to confirm.

Language

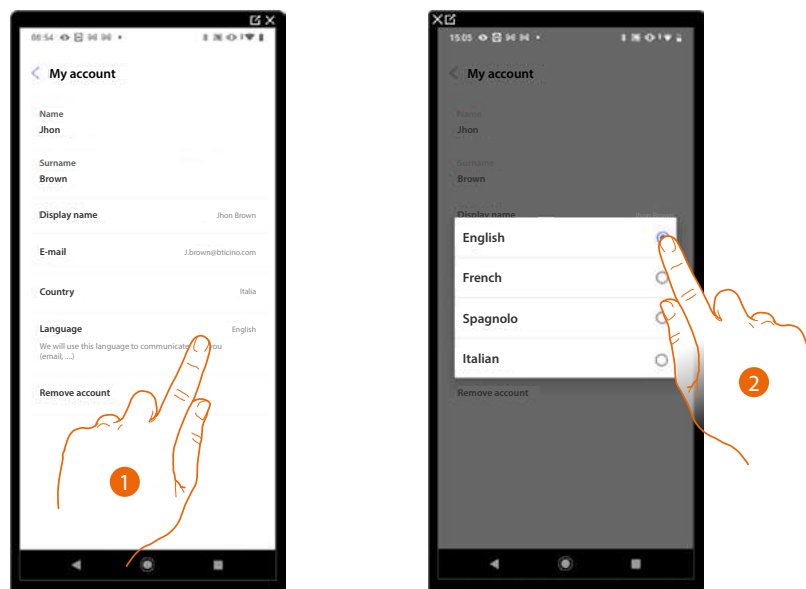

1. Touch to edit the language in which to receive communications.
2. Select the language.

Delete the account

In this page it is possible to permanently delete your Legrand account, which can therefore no longer be used for the Applications to which it was associated.

NOTE: when deleting the account, all the data associated with the Applications will also be lost.

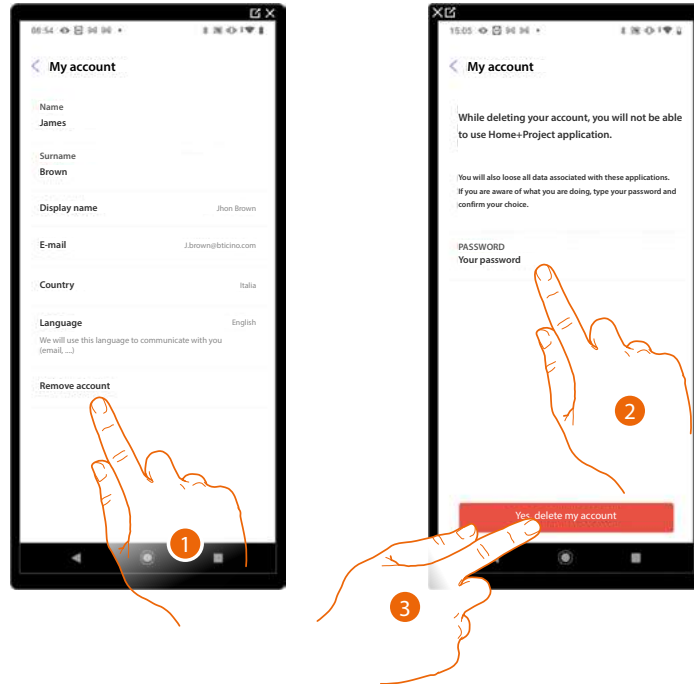

1. Touch to delete your Legrand account definitively.
2. Enter the password.
3. Touch to delete the account.

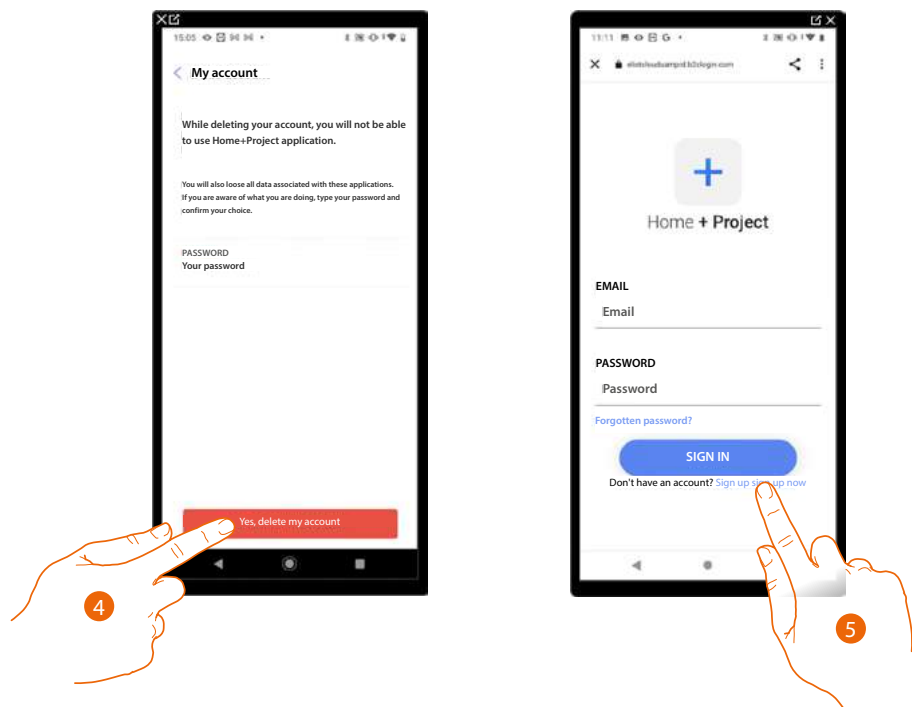

4. Touch to confirm.
5. At the end of the procedure, the authentication page will allow you to complete a [new registration](#).

Safety

In this page it is possible to edit the password of your account and to disconnect it from all devices. The disconnection of your account from all devices is useful in case one of your devices is lost or stolen.

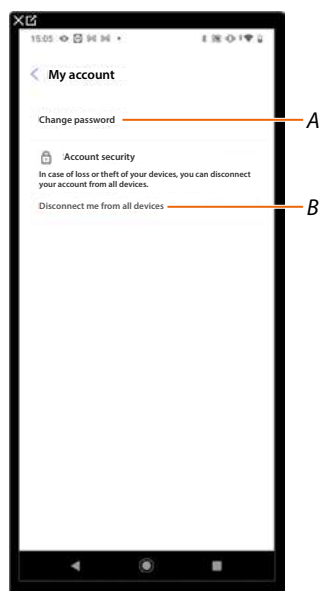

A Completes the password change procedure.

B Disconnects from all devices.

Edit password

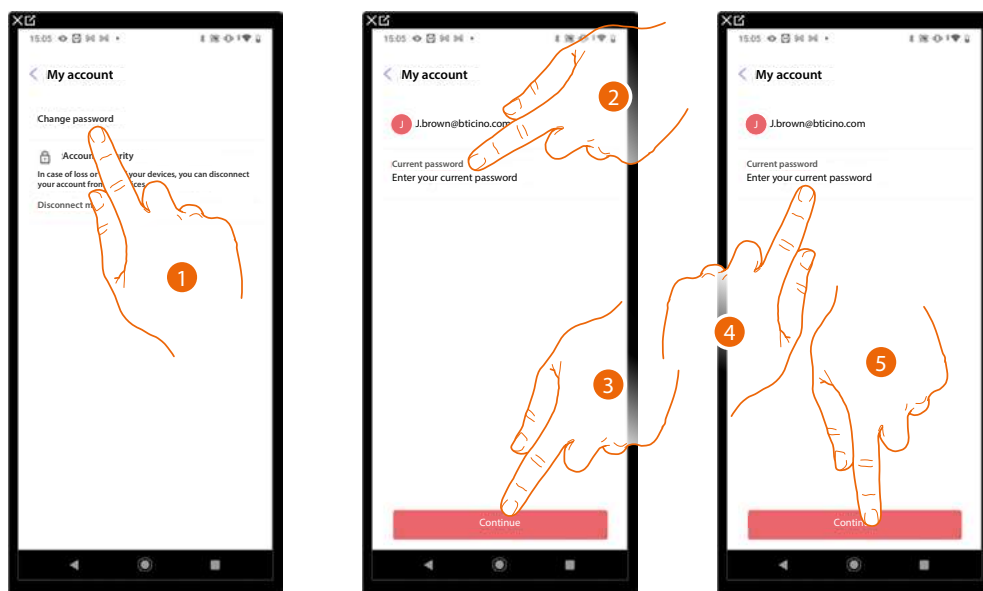

1. Touch to edit the password.
2. Enter the current password.
3. Touch to continue.
4. Enter the new password, which must meet the following requirements:
 - at least 8 characters;
 - at least one lower case letter (e.g. a);
 - at least one upper case letter (e.g. A);
 - at least one number (e.g. 1);
 - at least one special character (e.g. \$);
5. Touch to confirm.

Disconnect from all devices

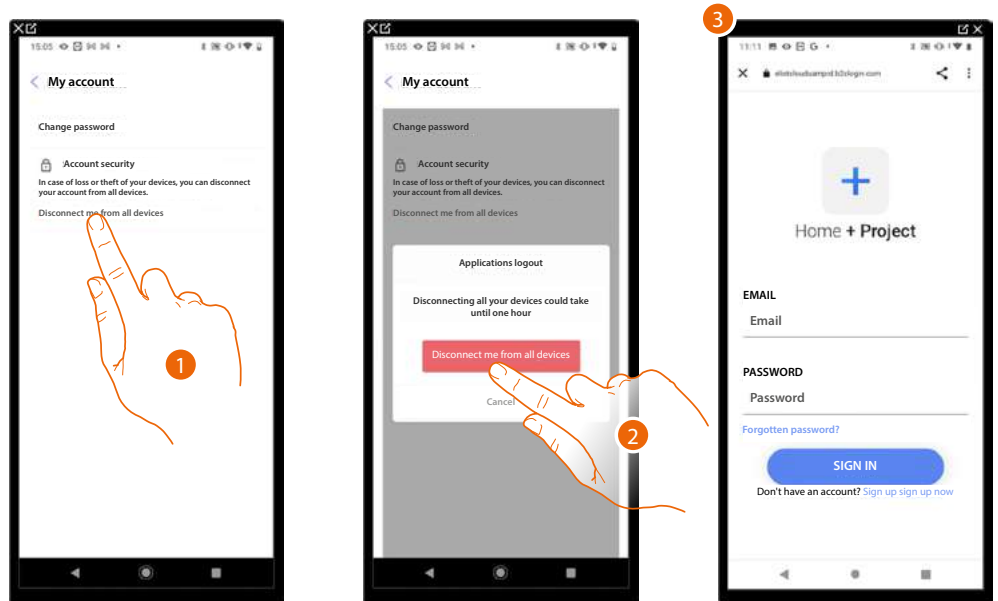

1. Touch to activate the procedure.
2. Touch to disconnect your account from all the devices and all the third-party applications.
3. The system automatically logs out from the application and the Home Page appears.

Improvement program

This section can be used to enable the sharing of the app usage data.

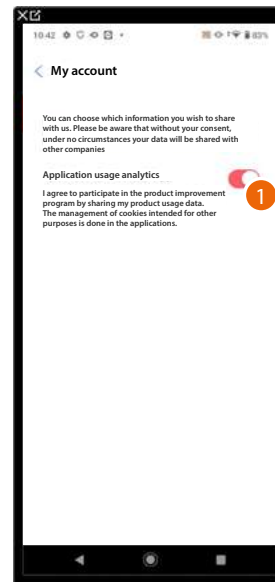

1. Touch to enable the sharing of the app usage data.

Communication preferences

In this page it is possible to enable the reception of communications from Legrand and the sharing of the app usage data.

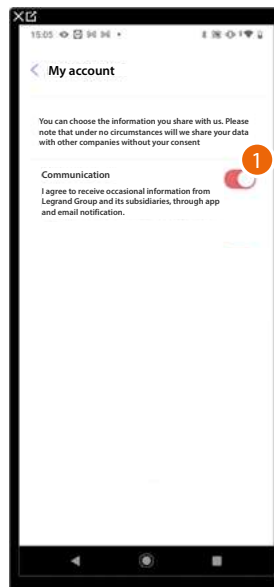

1. Touch to accept communications from Netatmo/Legrand/BTicino.

Legal information

In this page it is possible to view terms and conditions of use and privacy information for each app to which your Legrand account is associated.

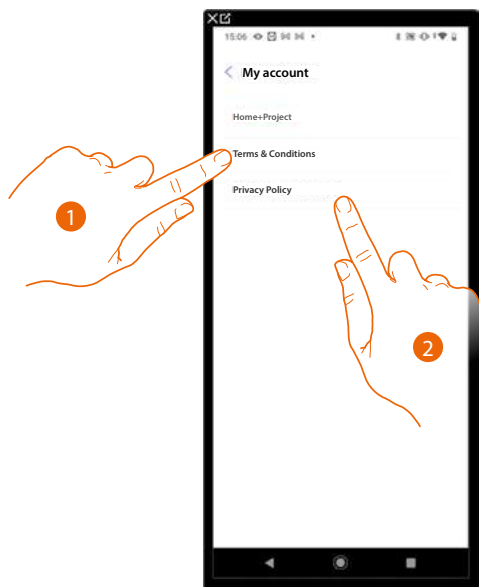

1. Touch to display Terms and Conditions.
2. Touch to view Privacy information.

Partner apps

In this page it is possible to display all the third parties to whom you granted rights to operate on your connected devices. (e.g. Google home, etc.)

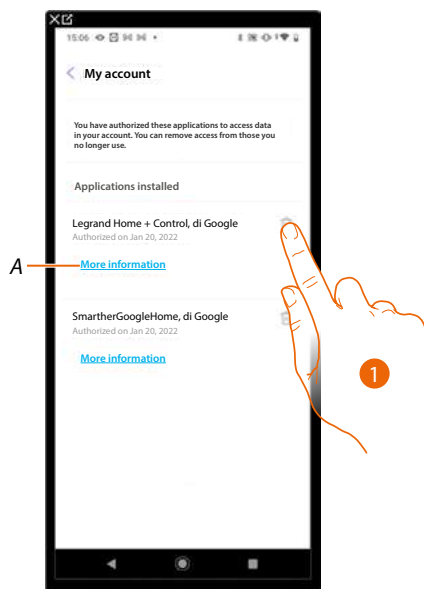

1. Touch to remove the access of sites or Apps to some of your account data.
- A Displays more information regarding the access to your system by partner Apps.

Help

In this page, it is possible to view and search for answers to frequently asked questions (FAQs) on the use of the Home+Project app, as well as submit a notification for a problem encountered.

NOTE: you will not receive a direct answer, but your signal will be used by developers to improve the service.

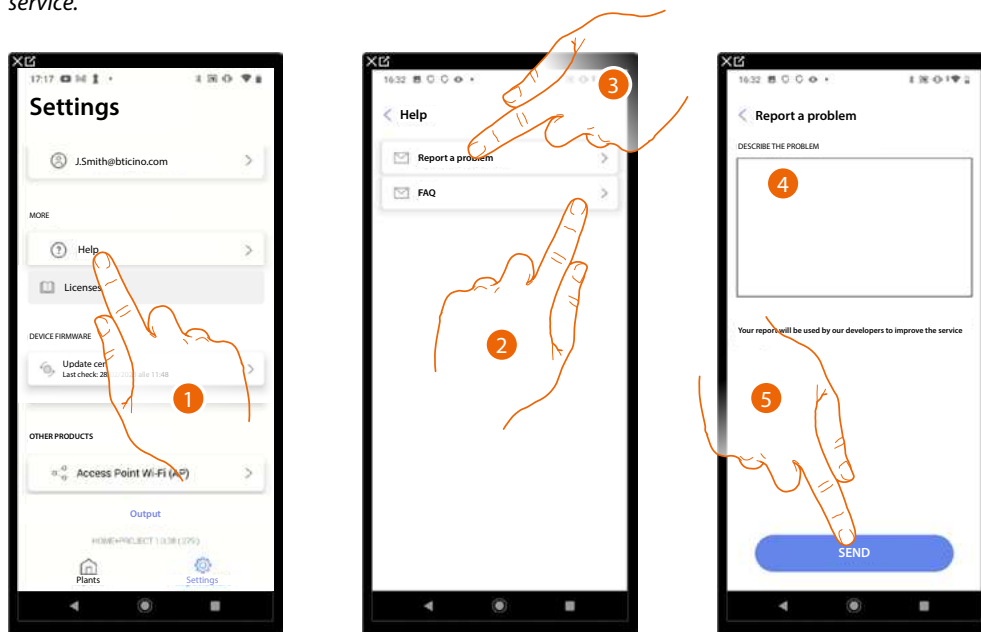

1. Touch to enter the Help page.
 2. Touch to enter FAQ section and select the topic on which you require clarifications.
- or
3. Touch to enter the page to point out a problem.
 4. Describe the problem you want to point out in the correct field.
 5. Touch to send the message to the after-sales service*.

***NOTE:** your feedback will be used by the developers to improve the product, but no reply will be sent to your comments.

Update Center

In this page it is possible to manage the device updates.

The update includes 2 steps.

In the first step, following a warning, it will be necessary to download the proposed update. This step requires internet connection on the smartphone.

In the second step, it will be necessary to install the update package. This does not require an internet connection but rather only access to the system.

NOTE: The procedure shown applies when the device is not connected to a network.

If it is connected to a network, the device downloads the updates automatically.

It will then only be necessary to send the installation command from the app (see steps 6 to 10 of the procedure).

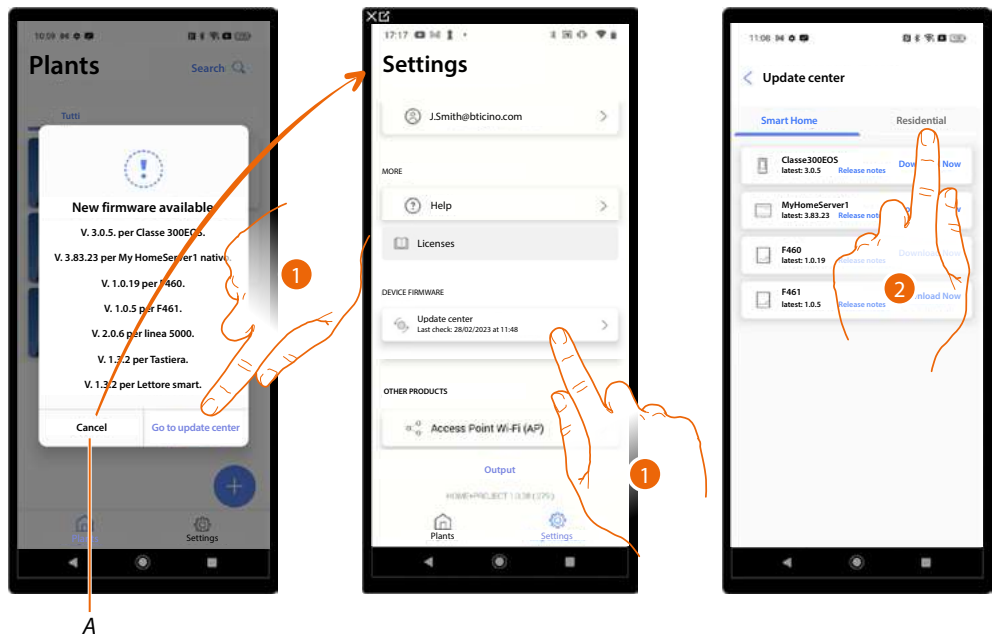

1. When new firmware is present, a notification appears on the system management Home Page. Touch to open the Update Centre. Alternatively, touch cancel (A) and open the update centre later.
2. Touch to open the page with the update to download.

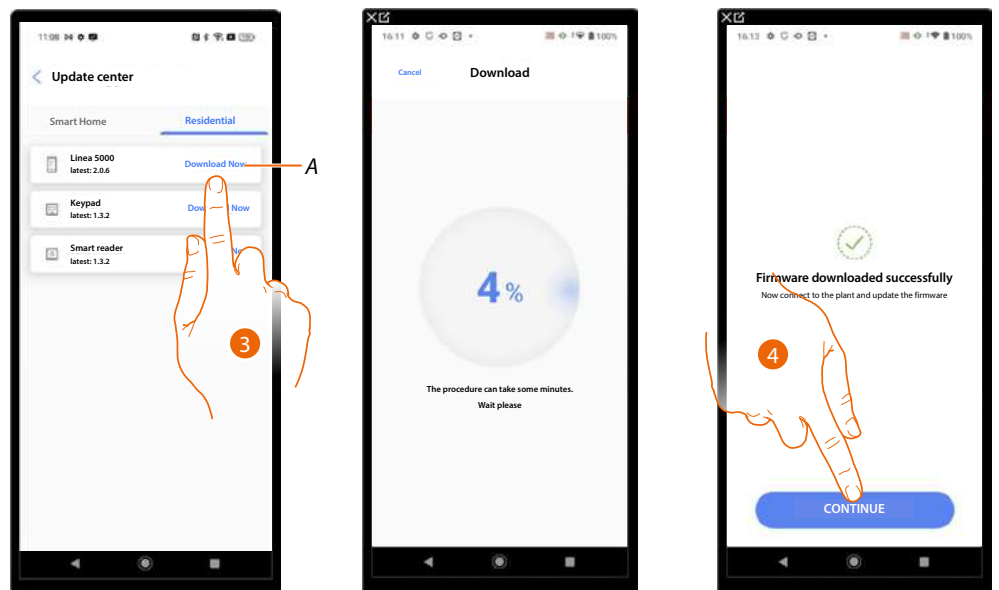

- A Update available for download.
3. Touch to download the update.
4. Touch to continue.

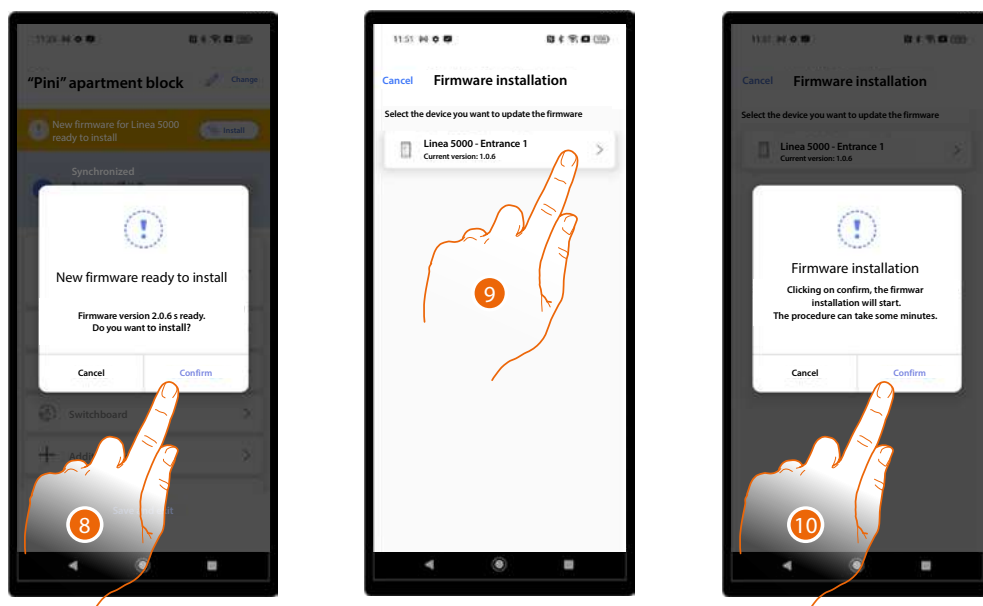
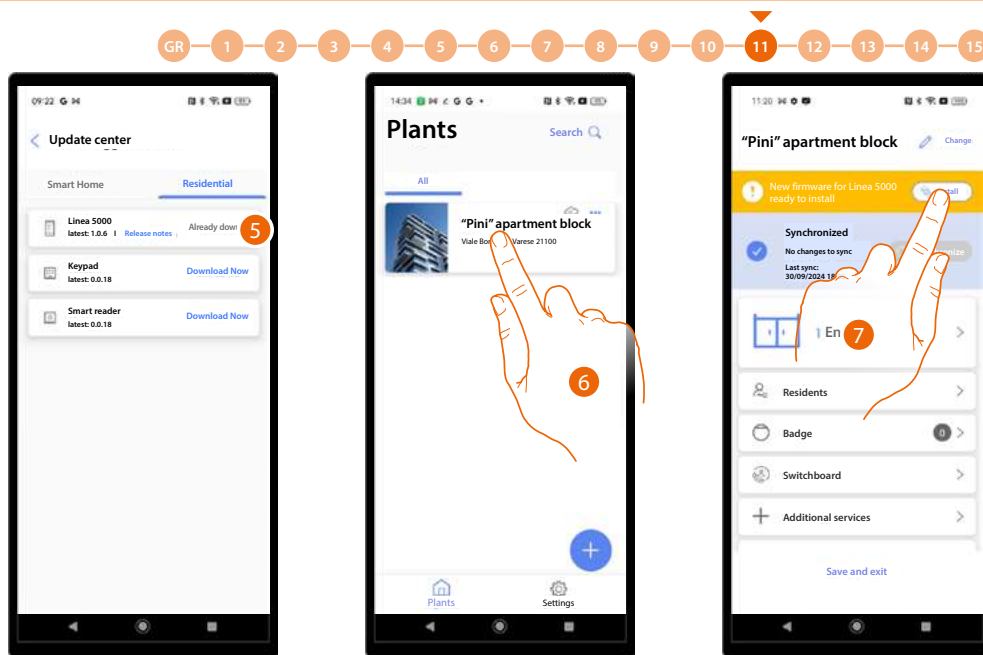

8. Touch to open the installation page, showing the devices affected by the update.
9. Select the device to which to send the update.
10. Touch to start the **update procedure**.



Update later

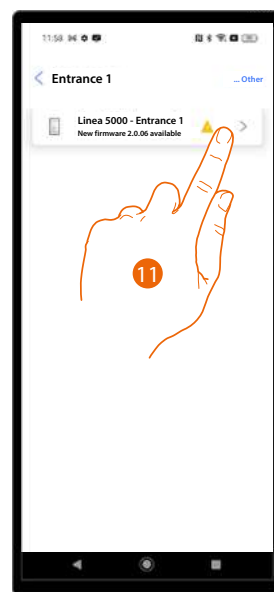
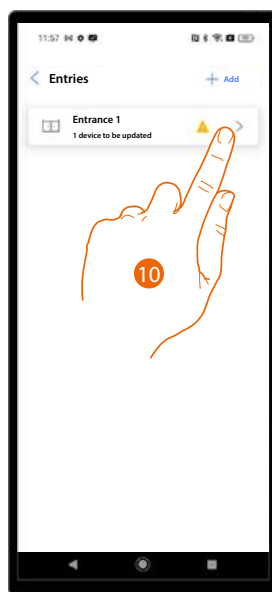
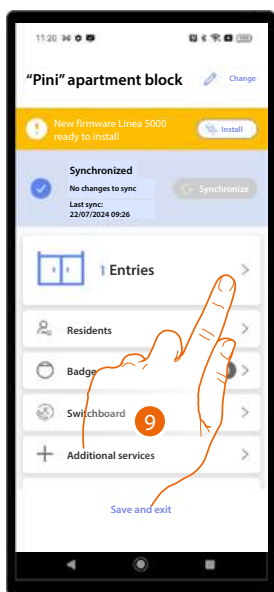

- 9. Touch to open the Entrance section.
- 10. Touch to select the entrance with the device to update.
- 11. Touch to select the device to update.

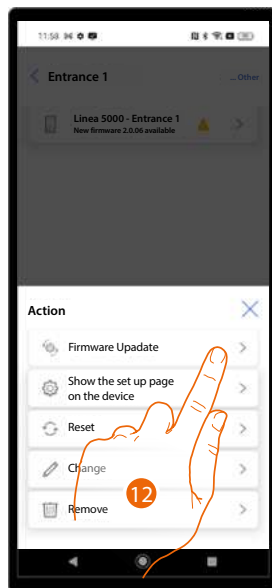

- 12. Touch to start the **update procedure**.

System Home Page

In this page are available all the functions for managing the system.
It is possible to:

- manage the entrances of the structure by connecting EP and other devices;
- create and manage apartment residents and access;
- manage access badges based on profile;
- manage the guard stations of the system;
- modify the structure and set the various parameters.

NOTE: The Home Page shown in the manual is for the "Installer" user with all functions active. The "Building Manager" does not have available certain functions; see [Basic Concepts](#) for details.
The images below show both pages, to highlight the differences.

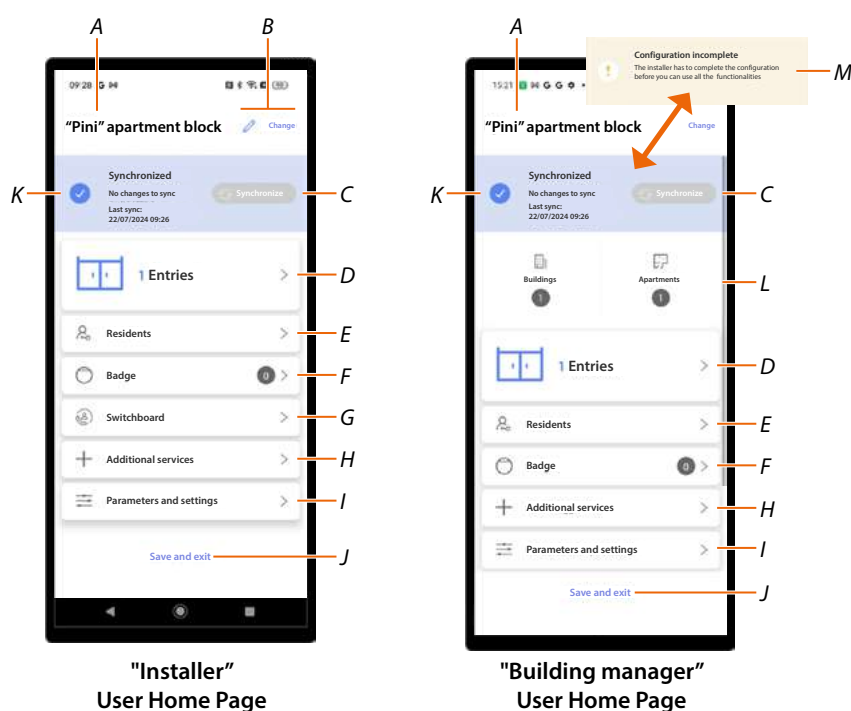

- A System name
- B Opens the system information management page (name, address, icon and group)
- C Starts the [Synchronisation](#)
- D Opens the page for the [Management of entrances by the "Installer" / "Building Manager" user](#)
- E Opens the page for the [Management of apartment residents](#)
- F Opens the [Structure access badge creation and management page](#)
- G Opens the page for the [Setting of the presence of one or more guard stations](#)
NOTE: this function is not available for the "Building Manager" user.
- H Opens the page for the [Creation of staff profiles and messages to forward to the EPs](#)
- I Opens the page for the [Setup of various parameters](#)
- J Saves the system and returns to the [App Home Page](#)
- K Displays system and EP status (configured/not configured)
- L Building structure indication
- M Indicates that the configuration of the entrances has not been completed.
Contact the installer to complete the configuration.

Entrances ("Installer" User)

This section can be used to manage the entrances configured during the [system creation and first configuration](#).

In particular, you can:

- [Manage the entrances](#)
- [Associate the devices with the entrances](#)
- [Manage the devices associated with the entrances](#)

Manage the entrances

Create a new entrance

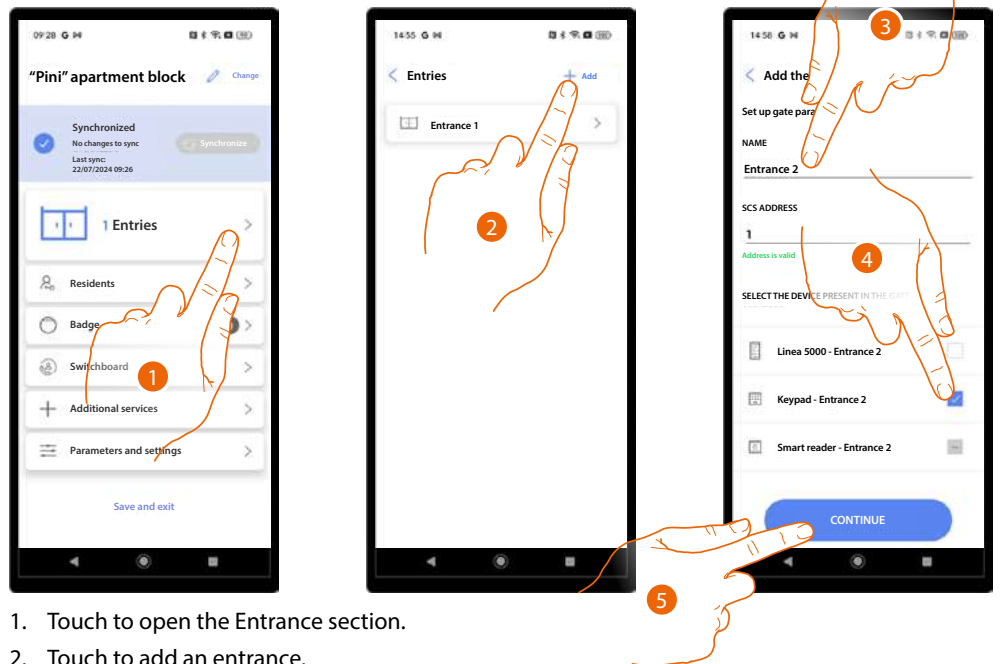

1. Touch to open the Entrance section.
2. Touch to add an entrance.
3. Enter a description.
4. Select the device.
5. Touch to continue.

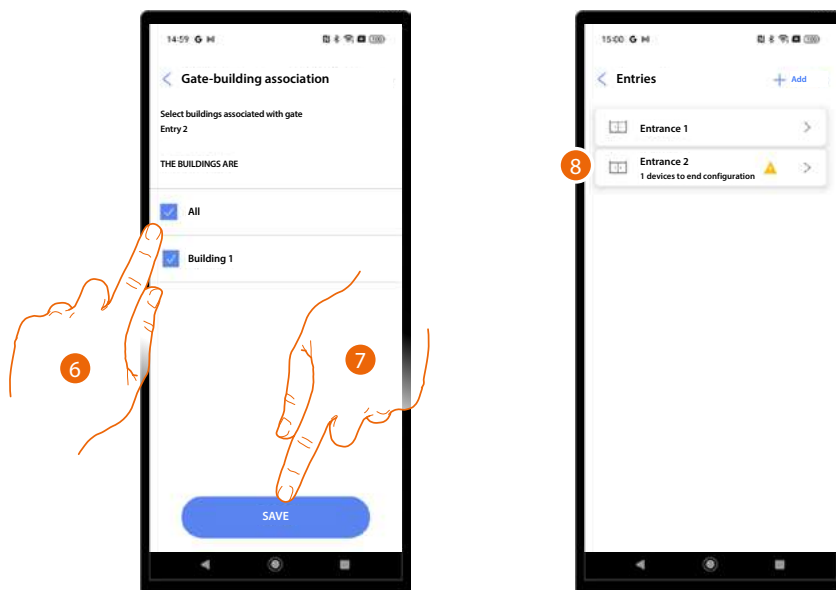

6. Select the buildings associated with the entrance.
7. Touch to save.
8. The entrance has been created.

Edit the entrance

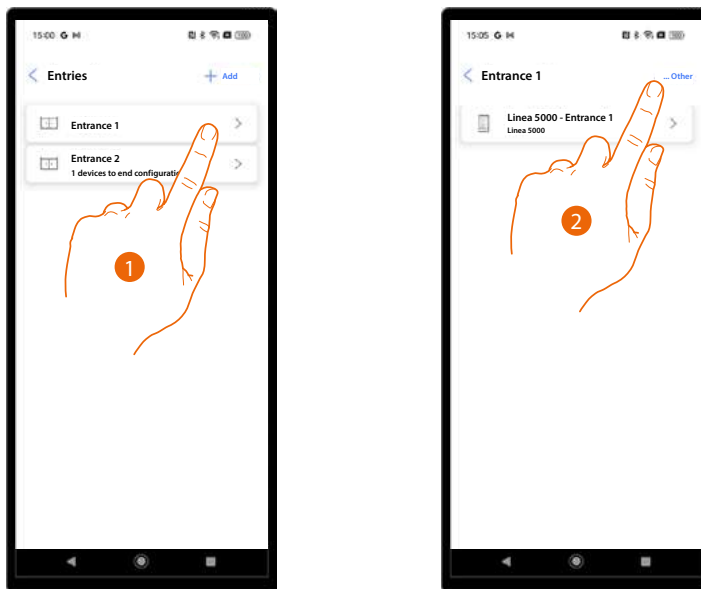

1. Select the entrance to edit.
2. Touch to open the entrance edit menu.

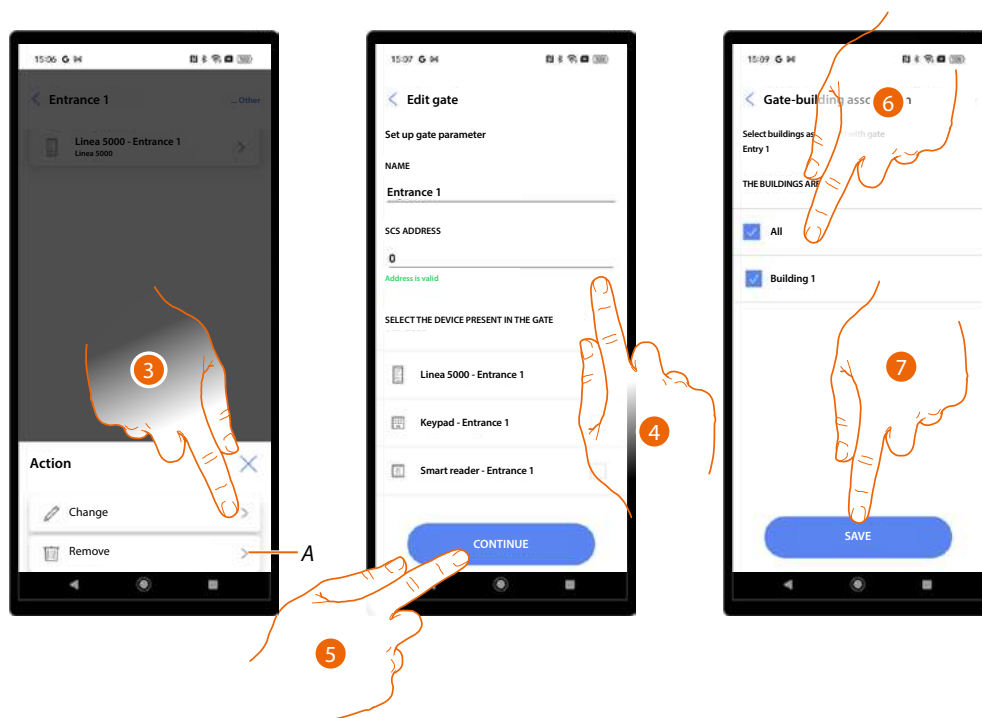

- A Delete the entrance.
3. Touch to edit the entrance.
4. Edit the name and SCS address of the device associated with the entrance.
5. Touch to continue.
6. Select the buildings associated with the entrance.
7. Touch to save.



Associate the devices with the entrances

The procedure for association with entrance devices depends on the type of device:

- [Association with the EP](#)
- [Association with the keypad](#)
- [Association with an RFID.](#)

For the differences among the various modules, see [Fundamental concepts](#)

ATTENTION: A project must always have an entrance with EP; it is not possible to create projects with only one exit associated to a keypad or RFID.
To also add a keypad or RFID, another exit must be created.

Association with the EP

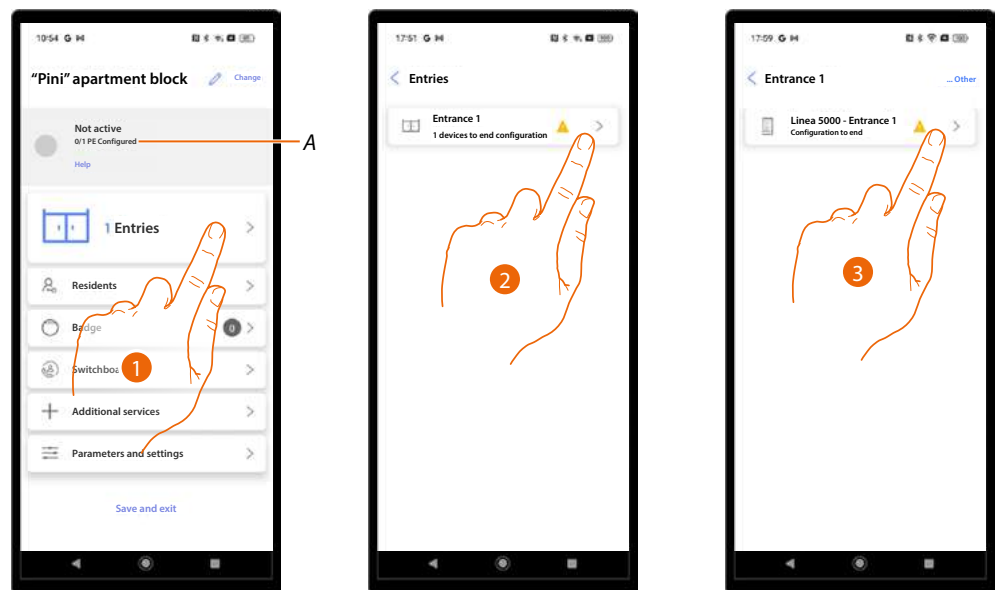

A Display of the total number of EPs in the system and the number of configured EPs.

1. Touch to start the association procedure.
2. An icon indicates the status of the entrances; touch the entrance with the device.
3. Touch the device to be associated.



4. Select the riser address (if any).

ATTENTION: if the system includes riser interfaces (BT-346851), after the configuration of the EP it will be necessary to disconnect the power from the interfaces and then reconnect it.

5. Enable if there is an additional lock in the system.

6. Enter the SCS address of the door lock actuator.

7. Touch to continue.

8. Enable the setting of the number of repetitions in case of no answer.

9. Scroll to set the number of repetitions.

10. Enable the setting of the duration of the activation of the relay of the associated lock.

11. If this option is selected, the duration of the activation corresponds to the duration of the pressure of the lock opening button.

12. Scroll to select the duration of the activation of the associated lock. This function is enabled in step 10.

13. Selecting this option will transfer the call to all the internal units of the apartment (use this function in single-family systems).

14. Selecting this option allows the user to activate the staircase light from the EP.

15. Touch to continue.



16. Select to define how call and door release are notified. There are 3 options:
 - Acoustic tones
 - Voice messages
 - No tone
17. This is used together with the settings of the internal unit to set the ringtone of the IU, with the possibility of different ringtones for calls from different entrance panels.*
18. Touch to continue.

***NOTE:** to set the call volume, perform the procedure directly from the device, by enabling the screen in the menu.

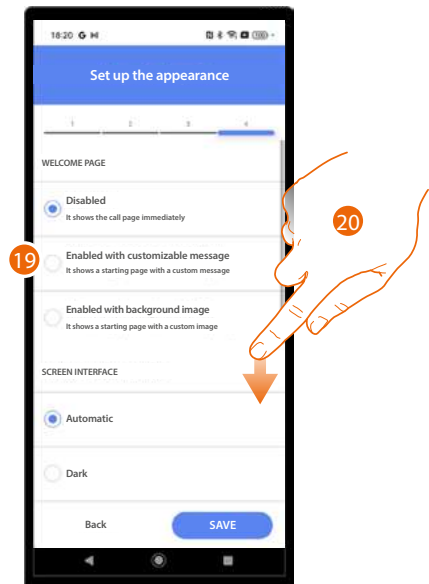

19. Select to define the appearance of the welcome page and the information displayed; there are 3 options:
 - No welcome page displayed. The call page is displayed instead
 - Home page with **custom message**
 - Home page with **background image**
20. Scroll to display other settings.

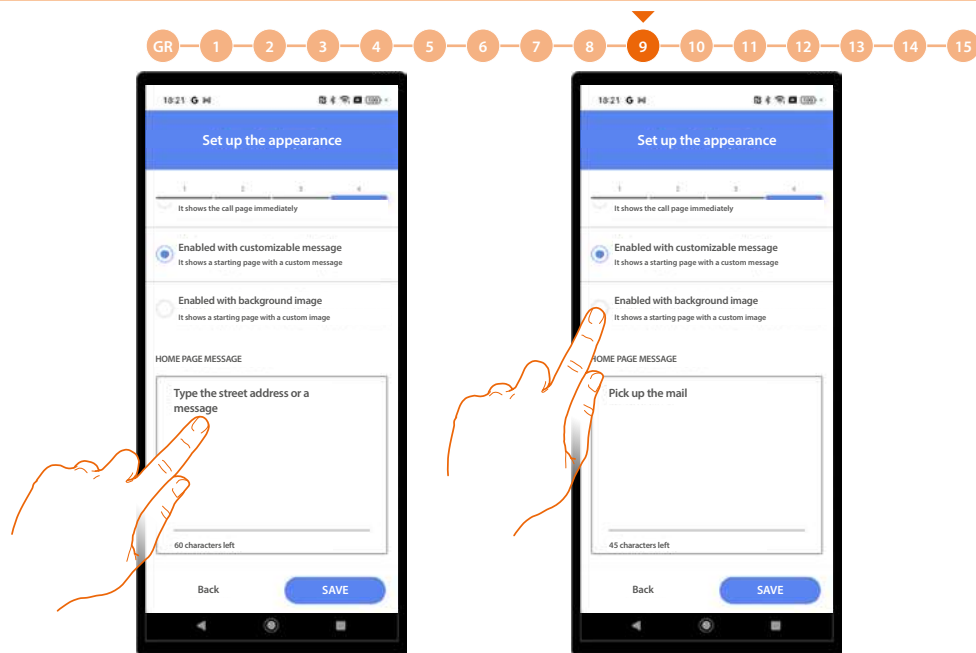

Type the message to be displayed on the welcome page

Touch to add the image that will appear on the welcome page

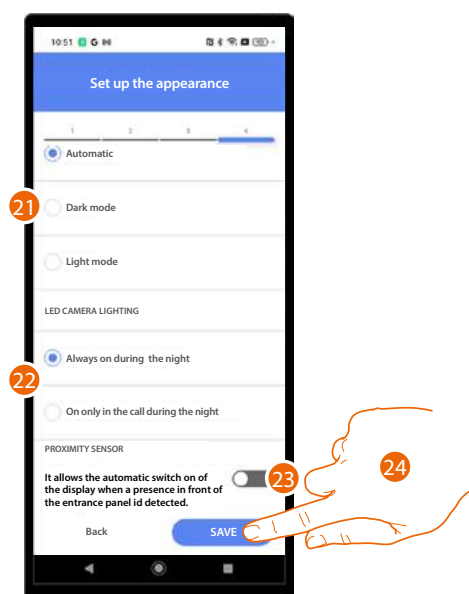

21. Select to set the screen theme: light, dark or adjusted to the external brightness
22. Set if the LEDs must always be on at night, or only during night calls.
23. Enable the automatic turning on of the screen when a presence is detected near the EP.
24. Touch to save.



Now you can decide to connect with the EP now or later, for example if you are setting it up while at the office.

CONNECT LATER

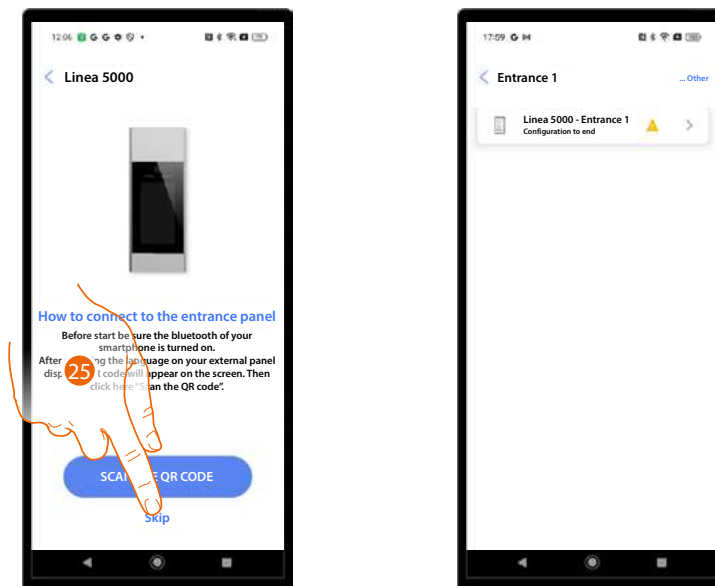

25. Touch to save the parameters and skip the connection to the EP, which can be done later.

CONNECT NOW

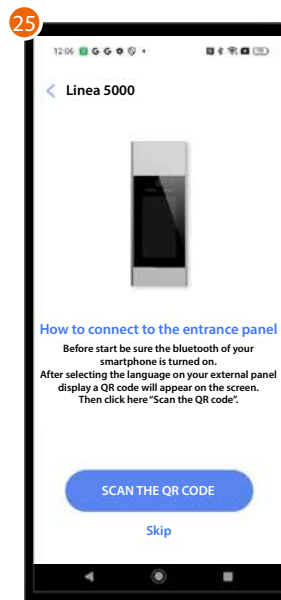

25. A tutorial guides you through the association procedure.

NOTE: Make sure Bluetooth is enabled on your smartphone.

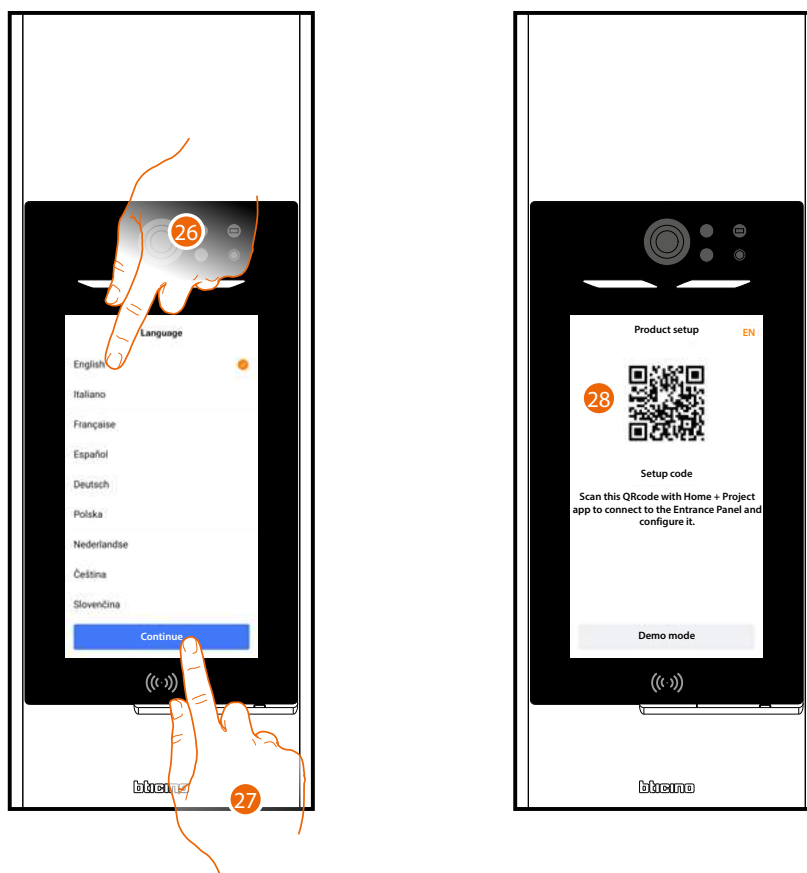

26. When switched on for the first time, the device shows the language selection screen: touch to select the language.

27. Touch to continue.

28. A QR code appears.

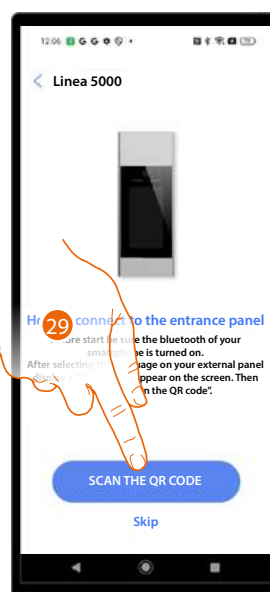

29. Touch to start the code scan.

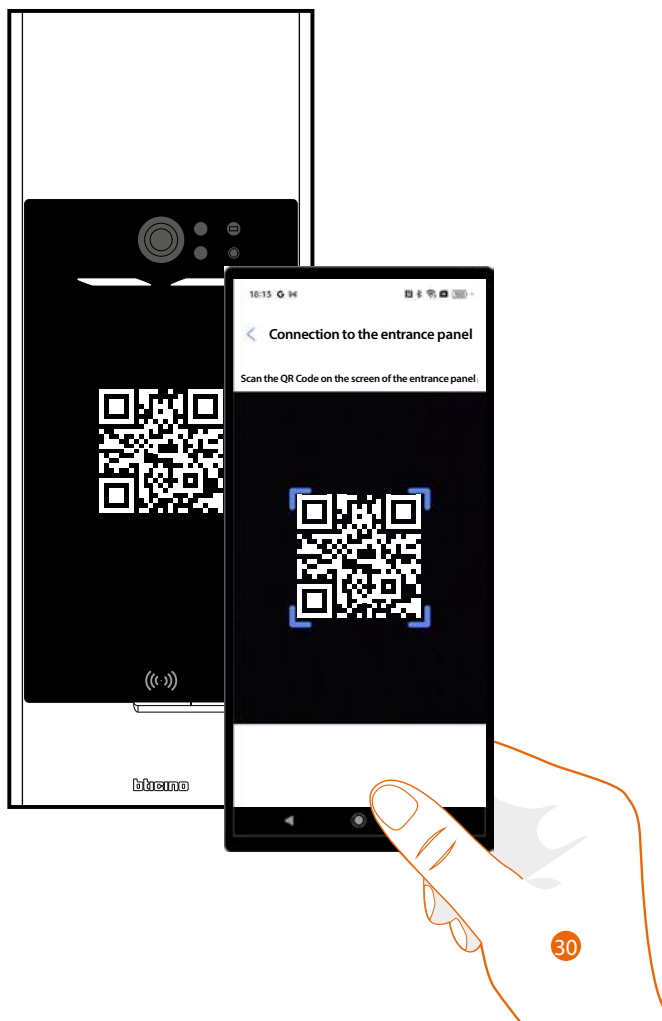

30. Using the smartphone, scan the QR Code.

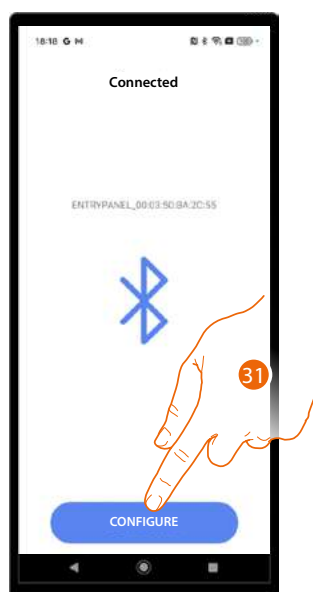

31. The device has been detected: touch to start the configuration.



The procedure is now complete, and the settings have been synchronised with the device. If changes are made to the parameters, the above procedure must be repeated, saving and sending the updated information via Bluetooth. These parameters are not sent with the synchronisation procedure (A), which is only for the address book.

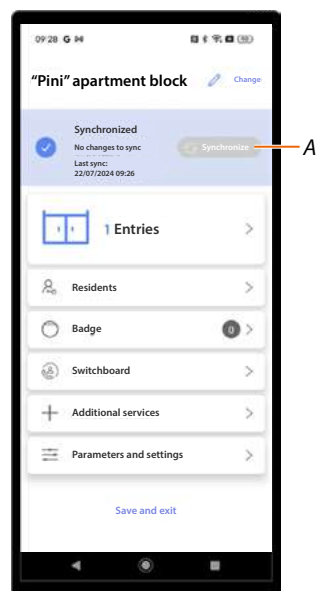



Association with the keypad

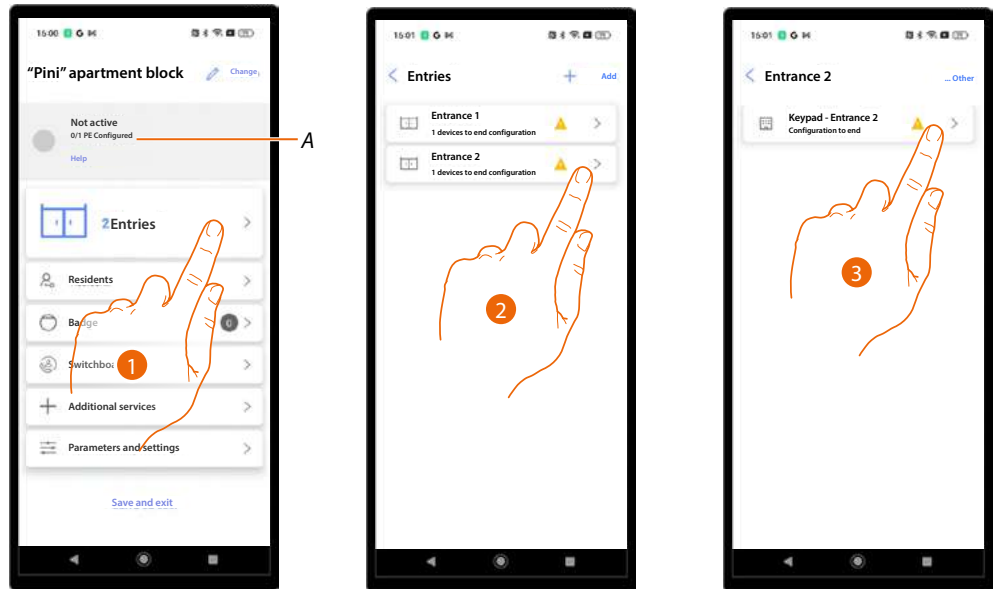

A Display of the total number of EPs in the system and the number of configured EPs.

1. Touch to start the association procedure.
2. An icon indicates the status of the entrances: touch the entrance with the keypad.
3. Touch the device to be associated.

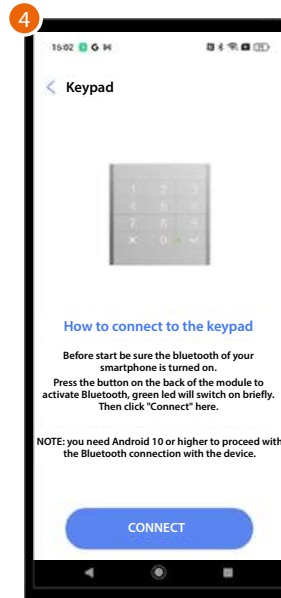

4. A tutorial guides you through the association procedure.

NOTE: Make sure that Bluetooth is enabled on your smartphone, that it is on, and the operating system is updated to Android® 10 or higher.

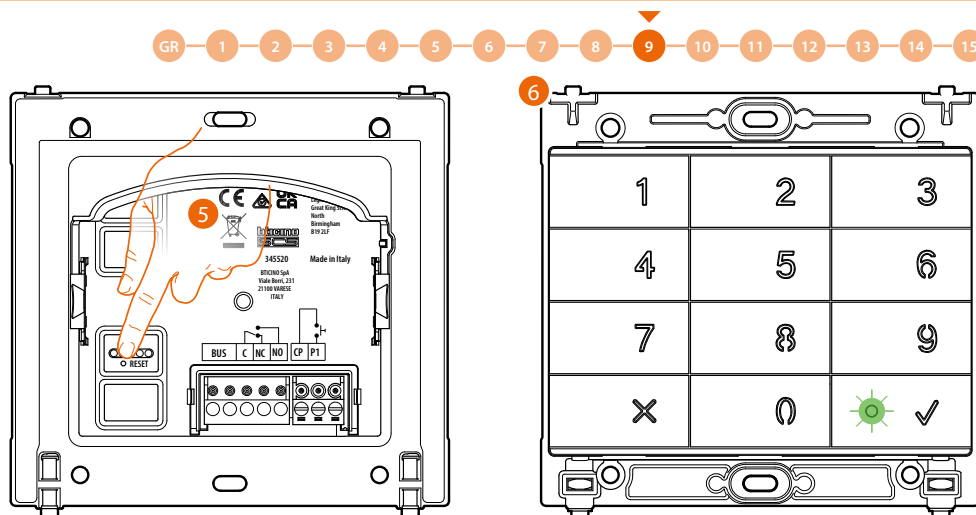

5. Briefly press the reset button on the back of the keypad.

NOTA: The pressure activates Bluetooth on the keypad; Bluetooth remains active for 5 minutes and then goes off.

You will need to press the button again to reactivate it.

6. The LED flashes green.

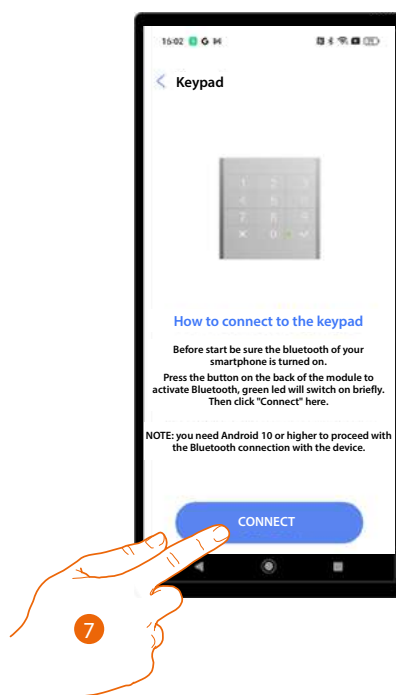

7. Touch to start the connection.

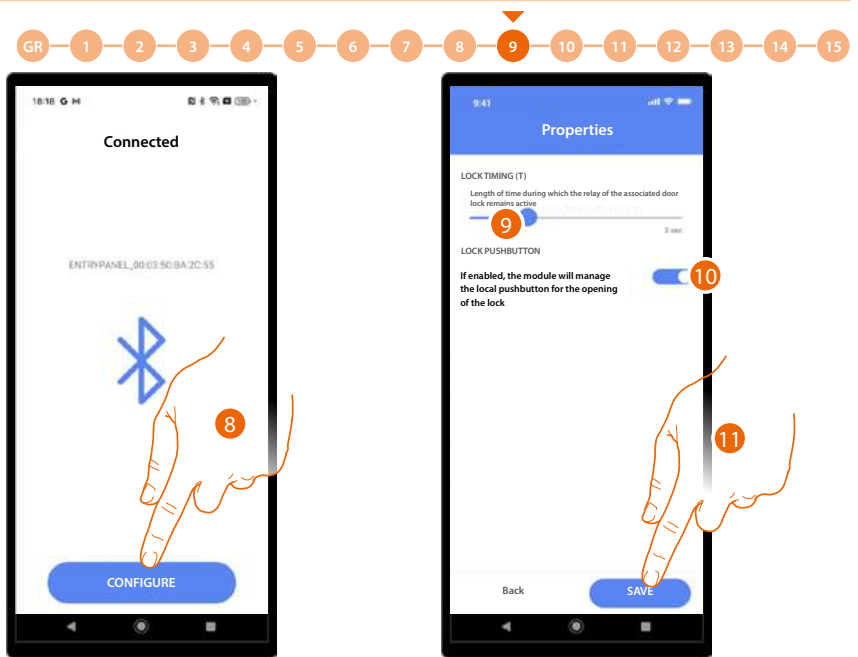

8. The device has been identified, touch to start the configuration.
9. Set the duration of the associated lock relay activation.
10. When this option is enabled, the keypad manages the local lock release button.
11. Touch to save the configuration.

The procedure is now complete, and the settings have been synchronised with the device. If the parameters are changed, the above procedure must be repeated and the updated information must be resent via Bluetooth: These parameters are not sent with the synchronisation procedure (A), which is only for the address book.

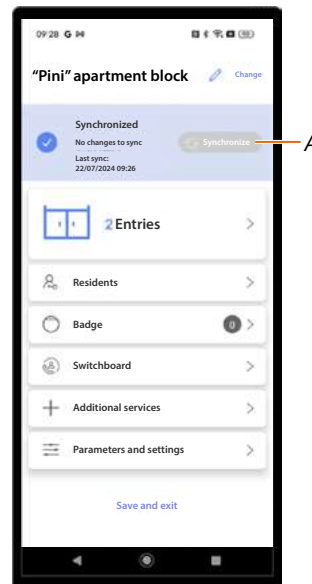



Association with an RFID

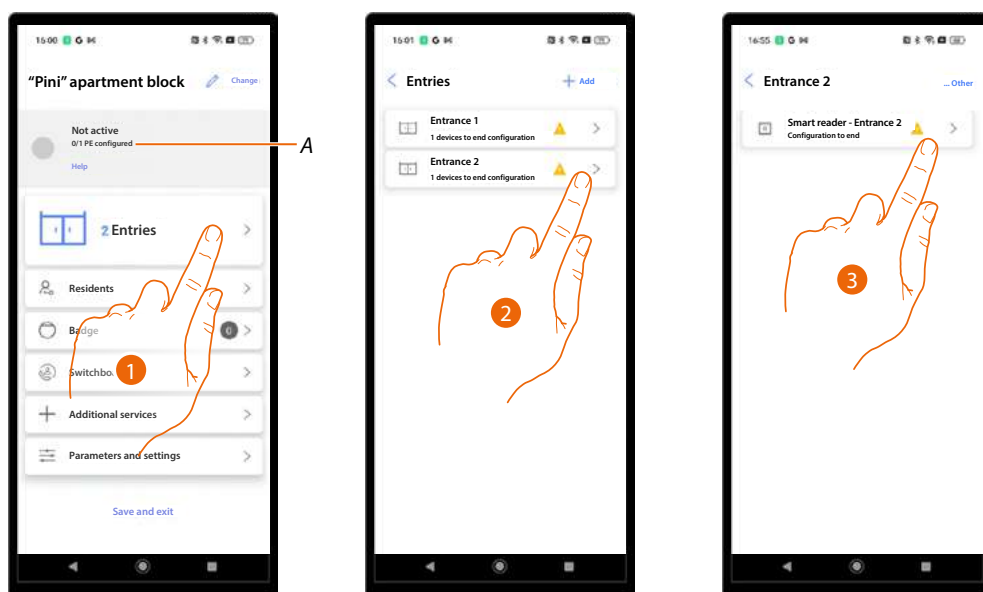

A Display of the total number of EPs in the system and the number of configured EPs.

1. Touch to start the association procedure.
2. An icon indicates the status of the entrances: touch the entrance with an RFID.
3. Touch the device to be associated.

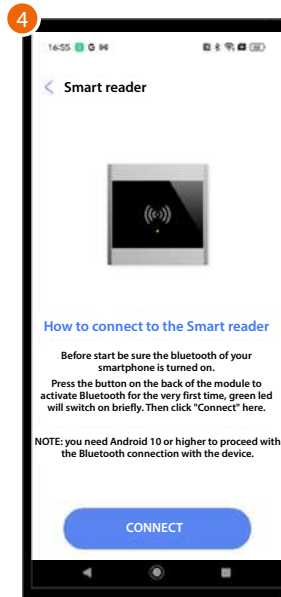

4. A tutorial guides you through the association procedure.

NOTE: Make sure that Bluetooth is enabled on your smartphone, that it is on, and the operating system is updated to Android® 10 or higher.

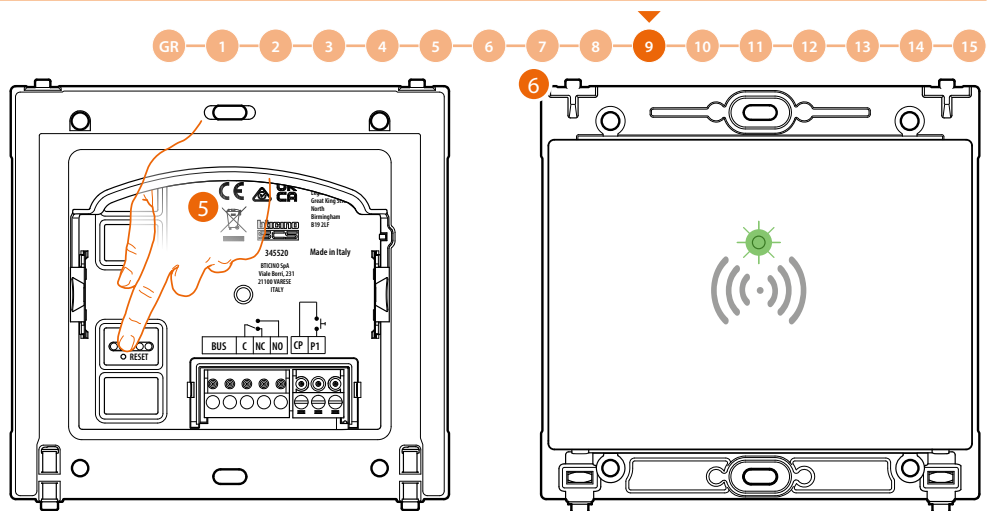

5. Briefly press the reset button on the back of the RFID.

NOTA: the pressure activates Bluetooth on the keypad; Bluetooth remains active for 5 minutes and then goes off.

You will need to press the button again to reactivate it.

6. The LED flashes green.



7. Touch to start the connection.

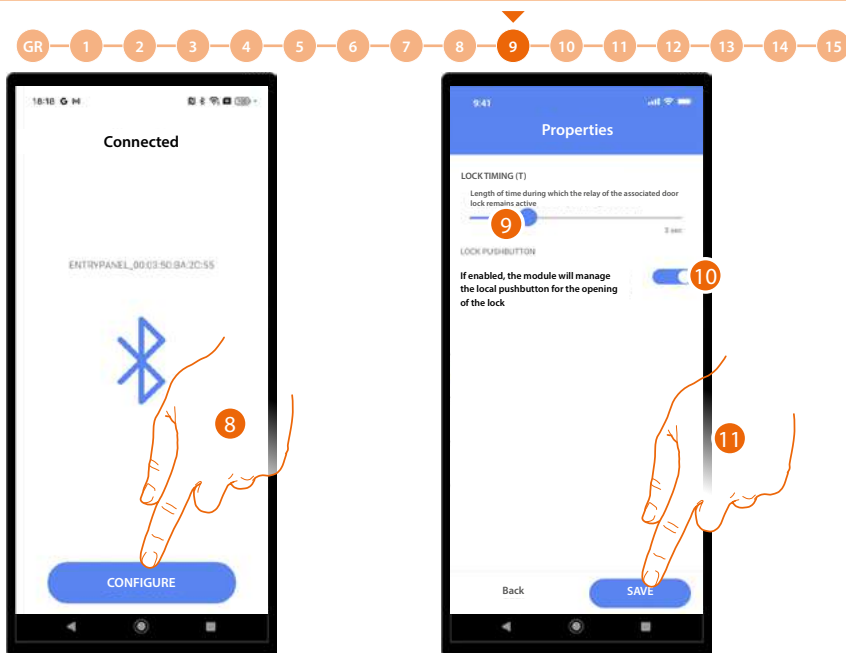

8. The device has been identified, touch to start the configuration.
9. Set the duration of the associated lock relay activation.
10. When this option is enabled, the RFID manages the local lock release button.
11. Touch to save the configuration.

The procedure is now complete, and the settings have been synchronised with the device. If the parameters are changed, the above procedure must be repeated and the updated information must be resent via Bluetooth: These parameters are not sent with the synchronisation procedure (A), which is only for the address book.

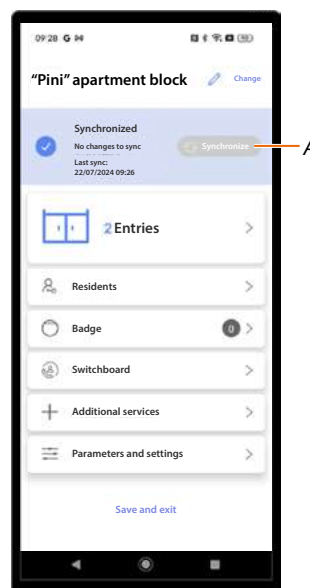

Manage the devices associated with the entrances

This section can be used to manage devices, performing various functions such as updating the firmware, changing or deleting and resetting the device.

It is also possible to enable on the device a menu containing settings that can be set using the device.

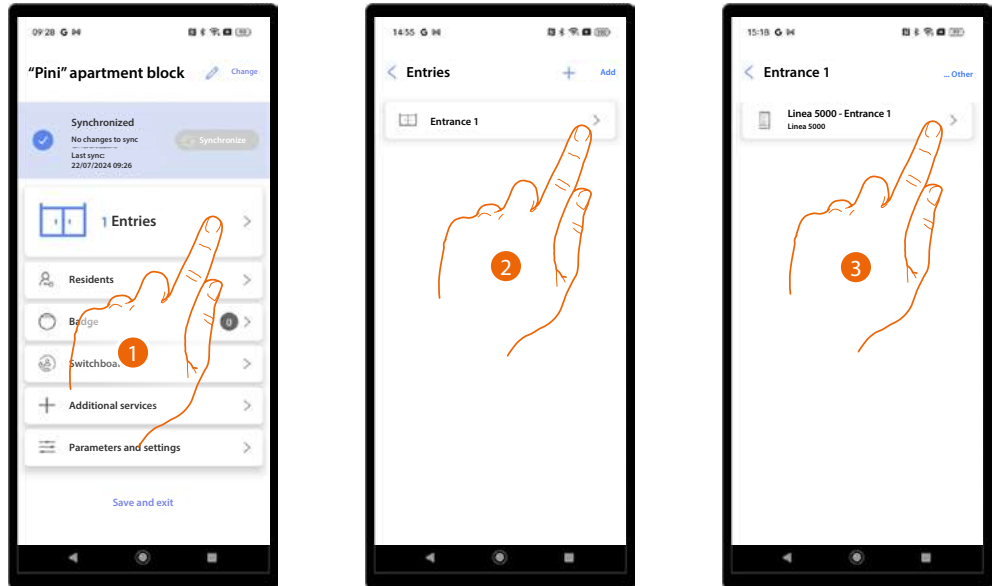

1. Touch to display the available entrances.
2. Touch the entrance associated with the device to manage.
3. Touch the device you want to manage.

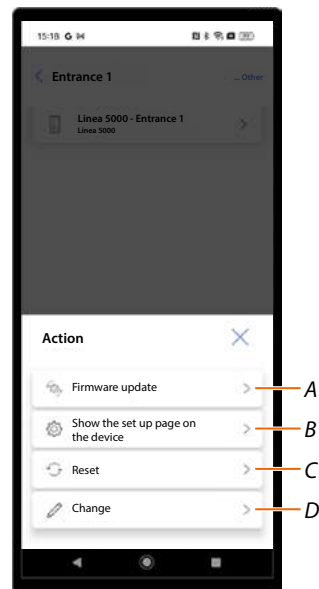

- A **Firmware update**
- B **Show the settings on the device (only for EP)**
- C **Reset**
- D **Modify**



Firmware update

This procedure can be used to install the firmware update on your device after downloading it from the [Update Centre](#).

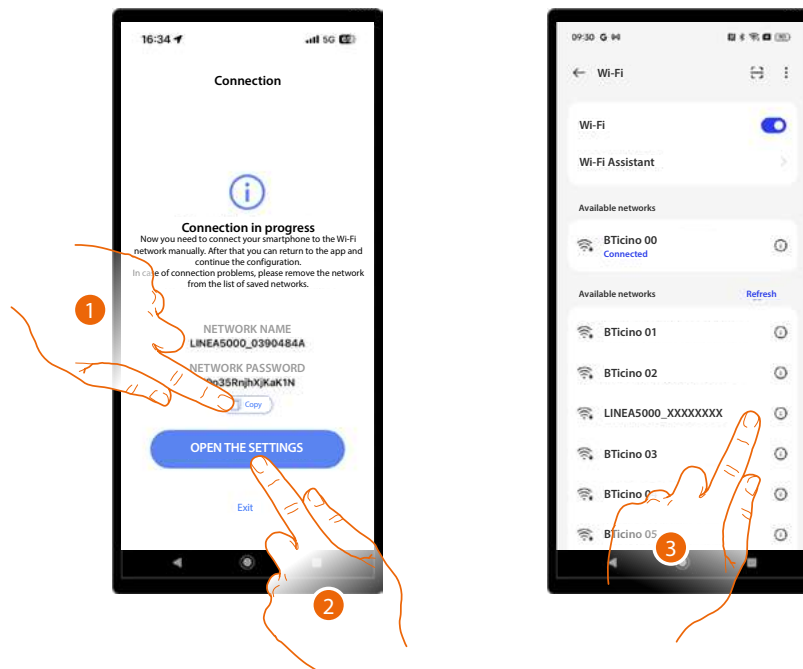

1. Take note of the network name (LINEA5000_XXXXXXXX) and copy the password.
2. Open the network menu of your smartphone.
3. Connect using the above details.

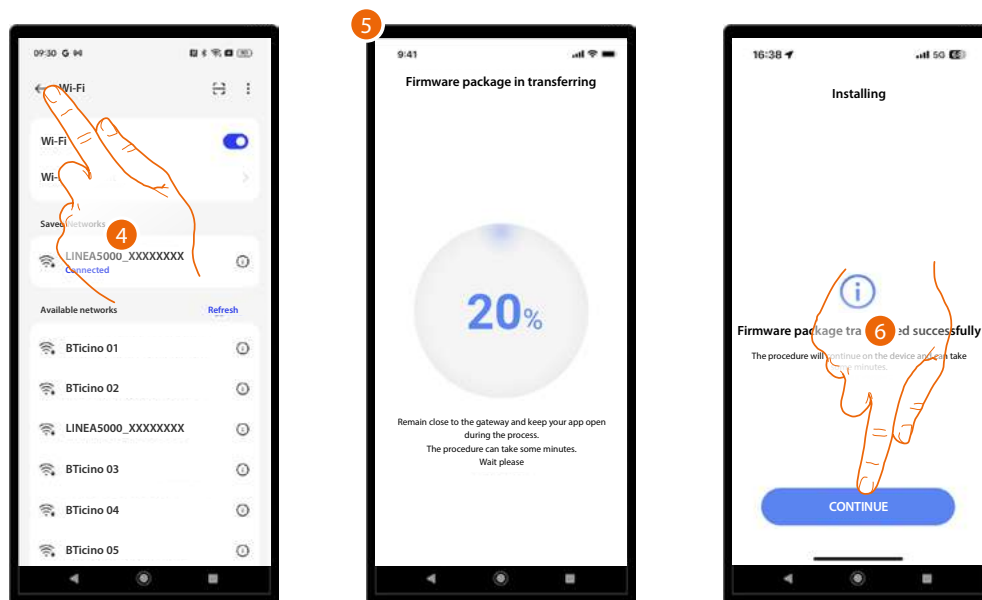

4. Return to the app.
5. During this, it is important not to move your smartphone away from the EP.
6. The firmware is being installed: touch to finish.

ATTENTION: the procedure is completed on the app side. However, it will continue for a few minutes on the device: do not switch off the device.

At the end of the procedure, the Home Page of the device will be displayed.

Show the settings on the device (only for EP)

This function can be used to display on the device a menu with various settings.

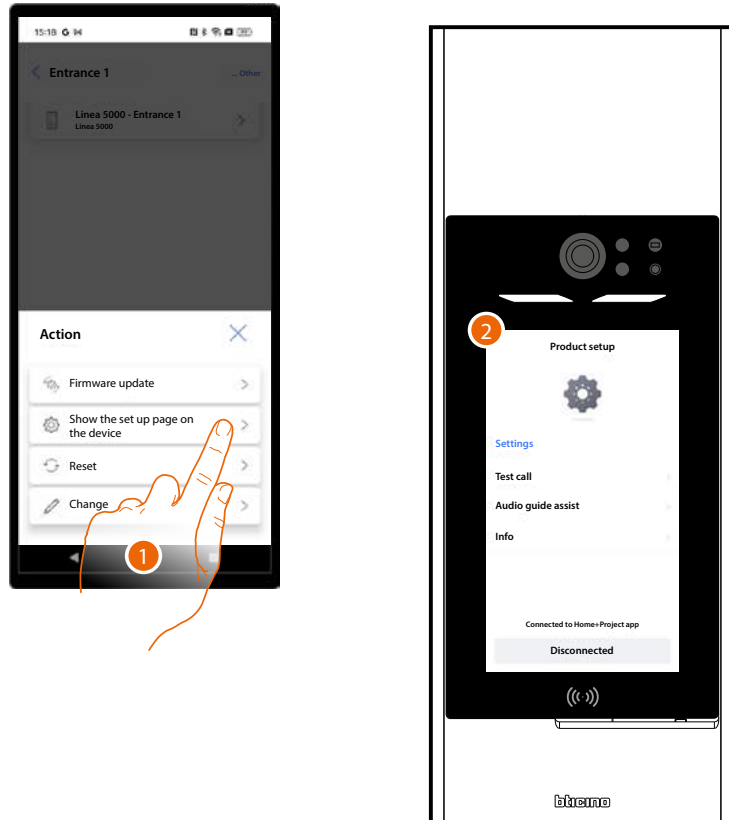

1. Touch to connect to the device and show the menu.
2. The device shows the product settings menu, which can be used to:
 - Perform a call test with an IU, and once connected set the speaker and microphone volume
 - Set the voice guidance volume if the [related function](#) has been set.
 - Display different device parameters.

See section [Configurations from device](#) for details.

Device reset

This function resets the device from the app.

Additional reset is possible directly from the device: see [Configurations from device](#).

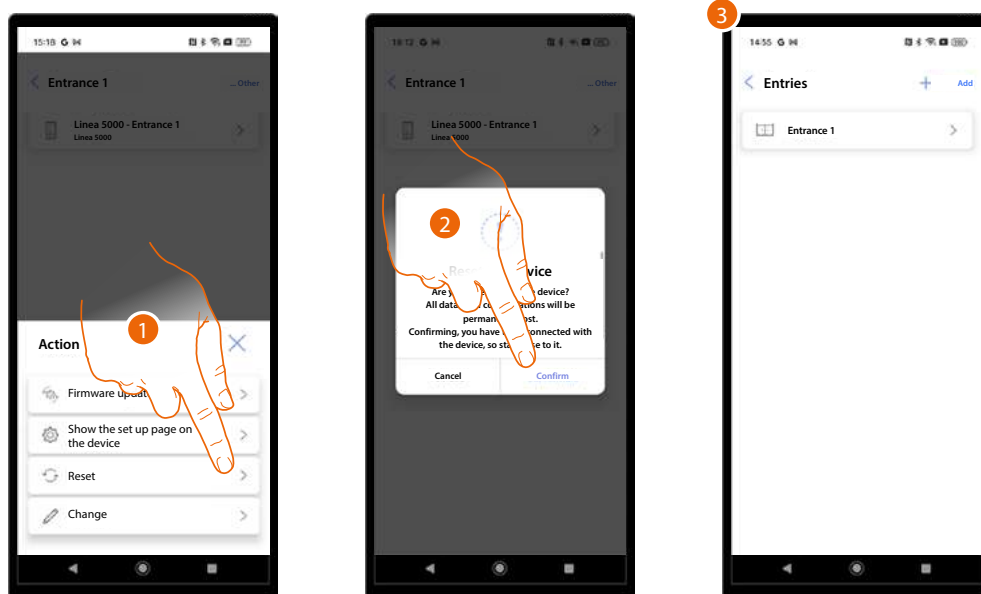

1. Touch to start the reset procedure.

ATTENTION: All data and configurations will be permanently lost.

2. Approach the device and touch to confirm.
The device on the system will be reset and restarted.
3. On completion, the device will need to be configured; run the [association](#) again.

Modify the device

This function can be used to change various device parameters.

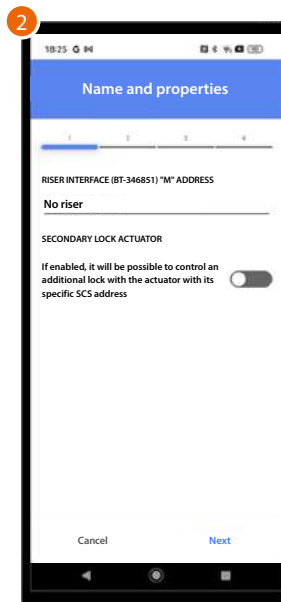
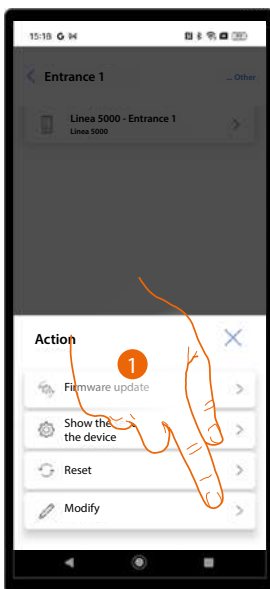

1. Touch to start the edit procedure.
2. A tutorial will show you how to change the parameters (see [Creation and first system configuration](#) for details).

Entrances ("Building manager" user)

In this section, it is possible to edit some parameters of the entrances associated with the devices.

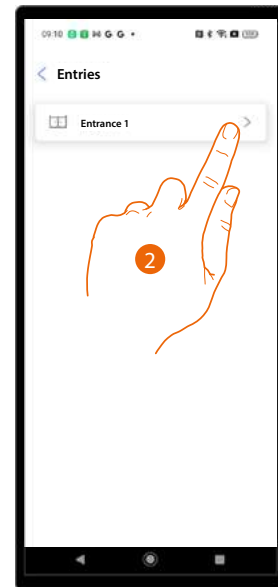
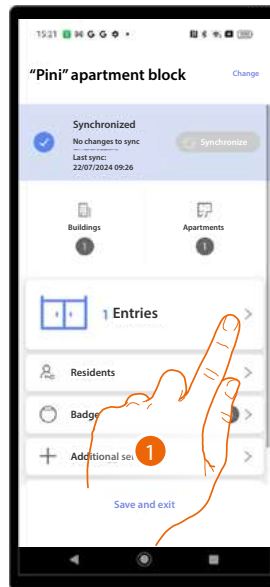

1. Touch to edit the entrance parameters.
2. Touch the entrance where there is the device.

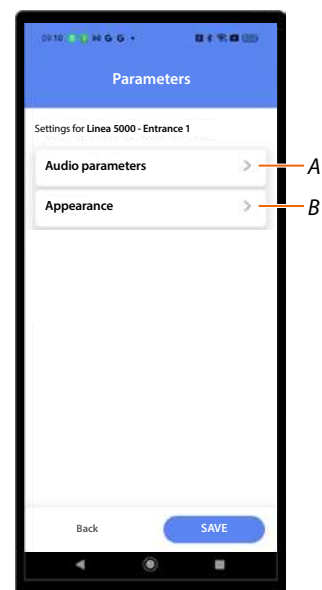
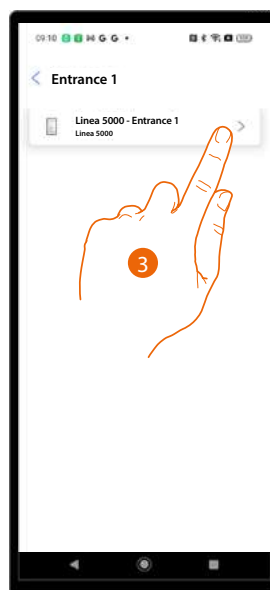

3. Touch the device for which to change parameters.
- A **Audio parameters**
- B **Appearance**

Audio parameters

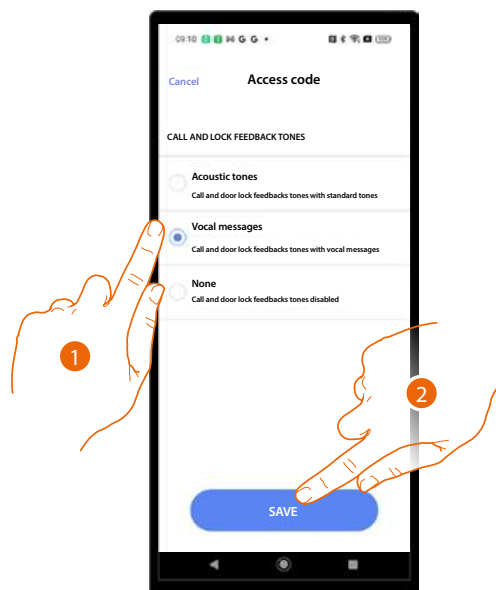

1. Select to define how call and door release are notified. There are 3 options:
 - Acoustic tones
 - Voice messages
 - No tone
2. Touch to save.

Appearance

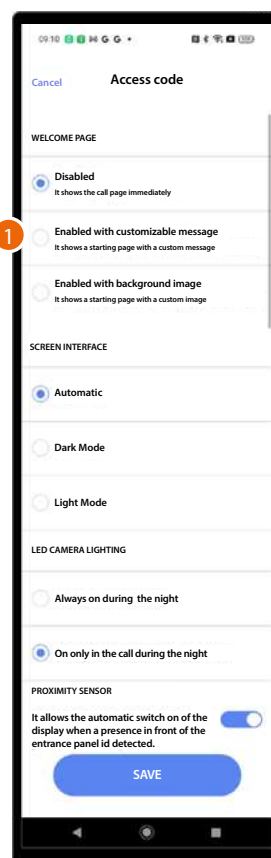

- Select to define the appearance of the welcome page and the information displayed; there are 3 options:
 - No welcome page displayed. The call page is displayed instead
 - Home page with **custom message**
 - Home page with **background image**

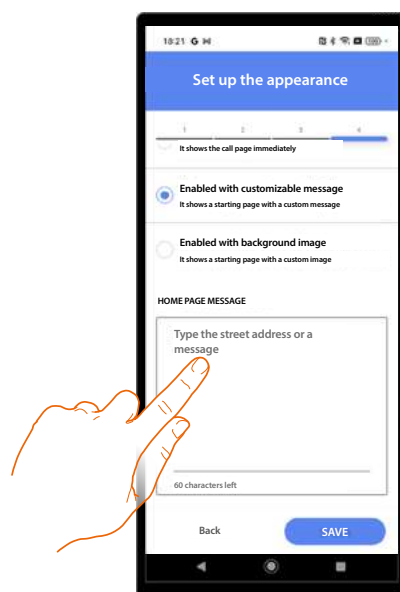

Type the message to be displayed on the welcome page

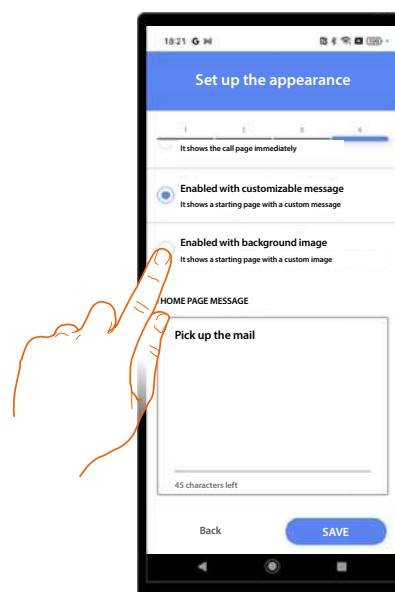

Touch to add the image that will appear on the welcome page

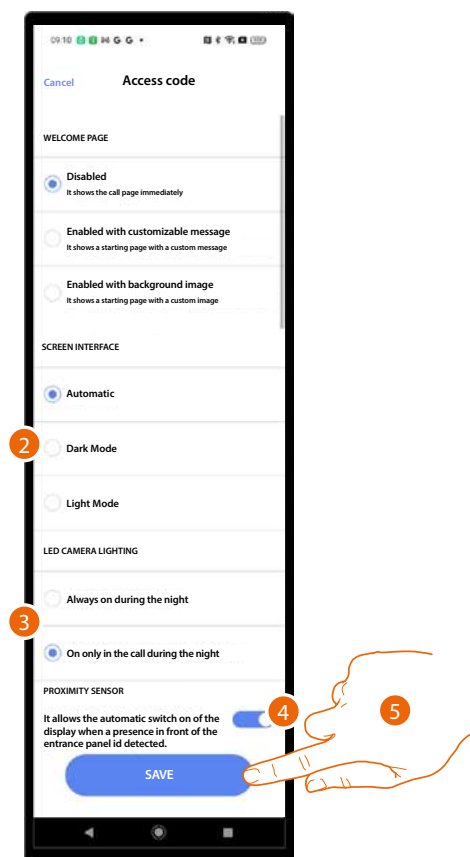

2. Select to set the screen theme: light, dark or adjusted to the external brightness.
3. Set if the LEDs must always be on at night, or only during night calls.
4. Enable the automatic turning on of the screen when a presence is detected near the EP.
5. Touch to save.

Synchronisation

After completing the first entrance association, in case of changes to the project, it will be possible to update the device using the "synchronise" button.

When using this function, the smartphone will connect via Bluetooth to the device and send the changes.

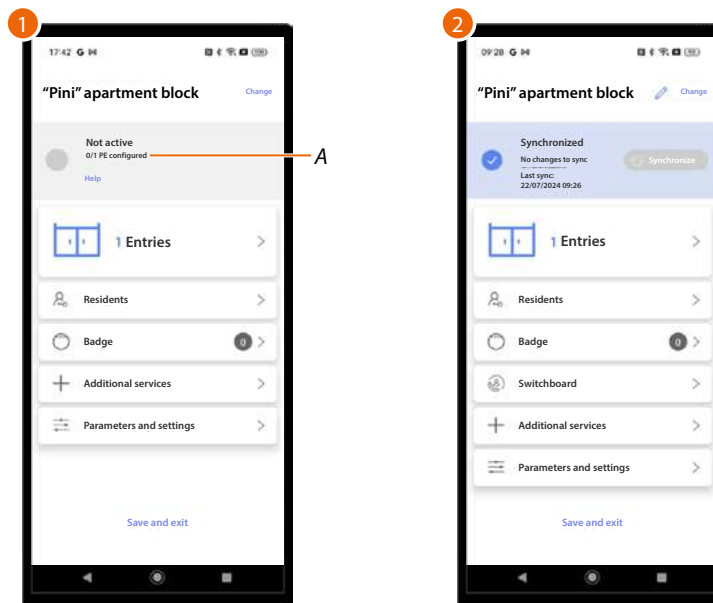

1. If no devices have been associated yet, the synchronise button does not appear, and a message indicates how many devices have been configured (A).

[Complete the association with the devices](#)

2. Now the device is synchronised.

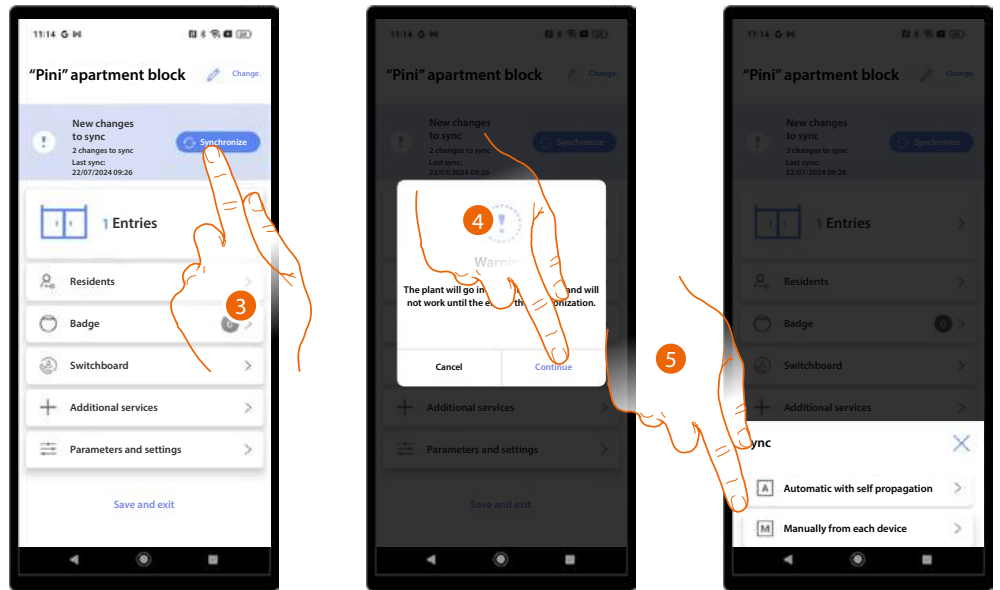

- When you make changes, the synchronise button comes on; touch to synchronise.
- Touch to continue.

NOTE: the system will not be available until synchronisation is complete

- Select the synchronisation method among the following:
 - Automatic through auto-propagation
 - Manual for each device

In the first case, the system will connect via Bluetooth to the connected EP, which will in turn automatically update all the others.

In the second case, you can individually synchronise each device via Bluetooth by moving close to the EP to be updated.

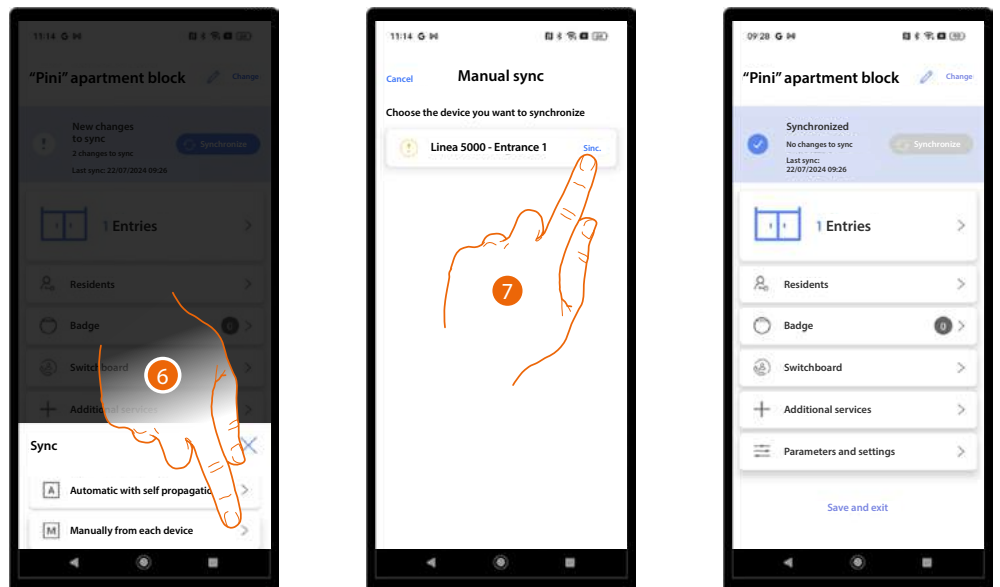

- Touch to update a single EP.
- Press the Sync button of the EP to synchronise.
- The EP is now synchronised with the latest changes.

NOTE: Some changes (e.g. addition/modification of entire apartments/entrances/guard stations) are only possible manually.

If the changes made are not compatible with the automatic method, the app will only propose synchronisation using the manual method.

Residents

This section can be used to manage the [entrances](#) configured during the [system creation and first configuration](#).

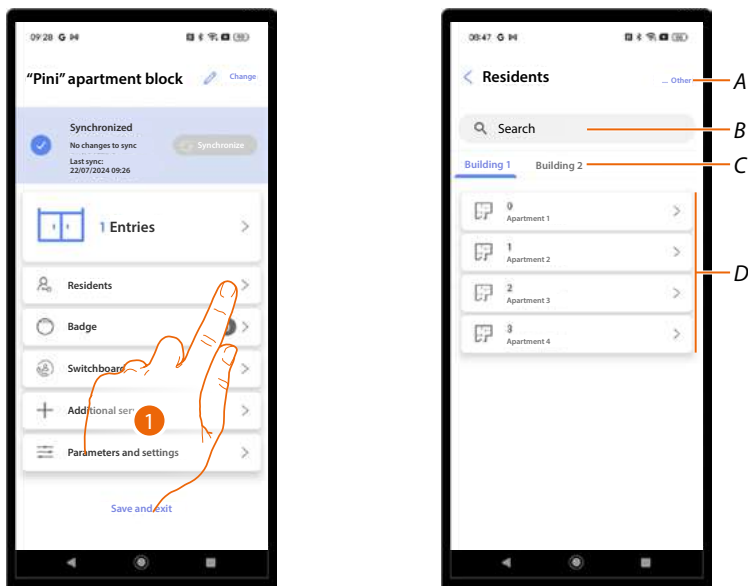

1. Touch to open the Residents section.
- A Select the [Mass Resident Invitation](#) function.
 - B Search for residents throughout the project.
 - C Select the building.
 - D Open the [apartment management](#) page.



Apartment management

When creating the system, a structure is also created, which varies according to the type of call. The lowest level of the structure is the apartment.

A default resident is created for each flat, to which a name is assigned, together with an IU SCS address in sequential order.

The pages present are:

- **Contact**: manages resident's data, creates new residents and invites other residents to manage certain functions from their smartphones using the Home+Security app
- **Entrance**: selects the entrances (with corresponding EP) to associate to the apartment. This association allows to:
 - receive calls
 - open a door lock using a code or keycard of the same apartment
- **Badge**: associates badges to open the lock of the EP associated with the apartment.
- **Access Code**: sets the code to open the lock of the EP associated with the apartment.

NOTE: Functions:

- add a resident in addition to the one created by default
 - delete the default resident
 - type of resident: private/business
- only available if the project has been set up as Address Book call type.

Contact

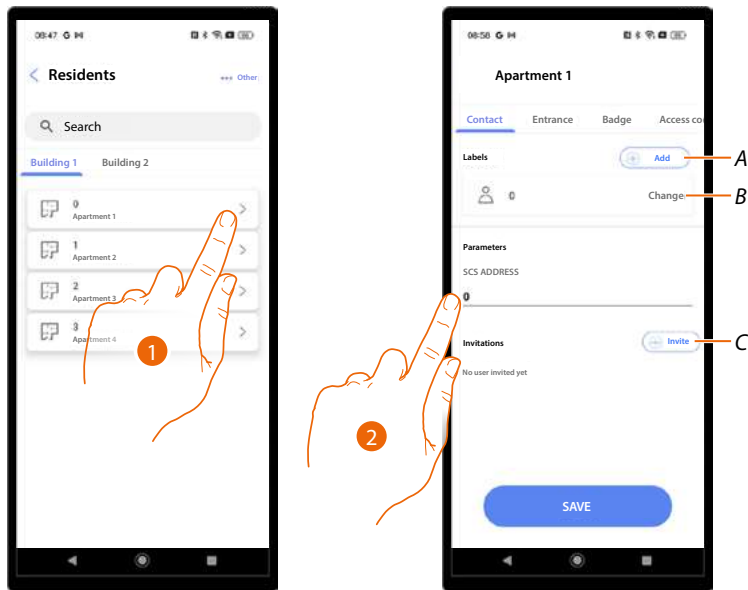

1. Touch to open the apartment management pages.
- A **Add a resident**
 - B **Edit a resident**
 - C **Invite a resident**
2. If necessary, edit the SCS address of the apartment IU.



Add a resident (only Address book call type)

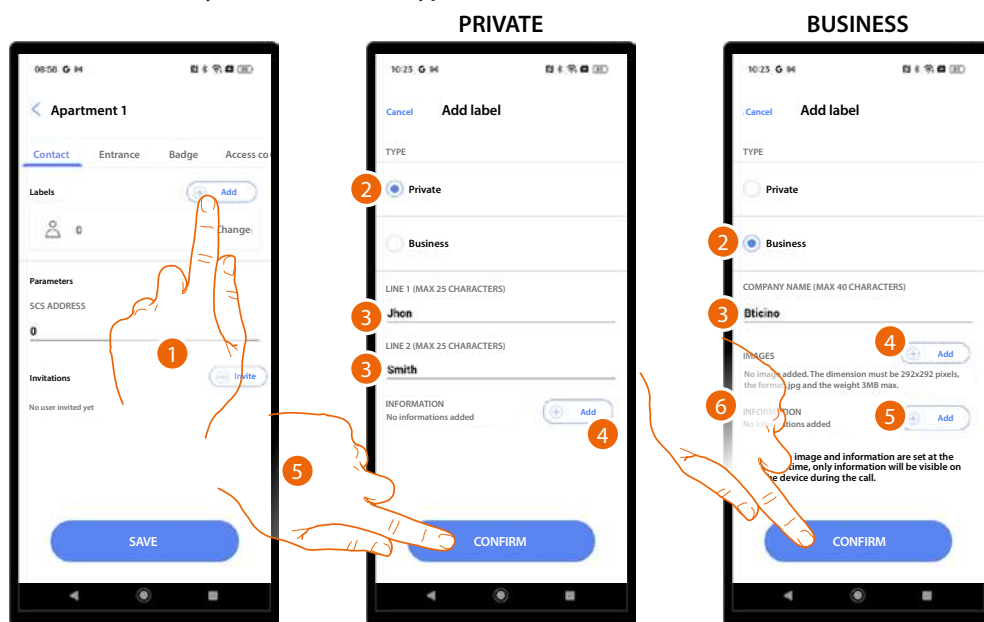

1. Touch to add a resident.
There are 2 types of residents, private or business. Different information must be entered for each one.

2. Select the type of resident.

PRIVATE:

- 3. Enter the name and surname to be displayed on the EP.
- 4. Enter the message to be displayed during the EP call.
- 5. Touch to confirm.

BUSINESS:

- 3. Enter the name of the company to be displayed on the EP.
- 4. Insert the image to be displayed on the EP.
- 5. Enter the message to be displayed during the EP call.

ATTENTION: if both image and information have been added, only the latter will be visible on the device during the call.

6. Touch to confirm.

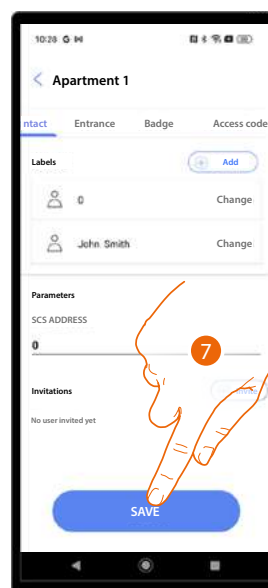

7. The resident has been created, touch to save.



Edit a resident

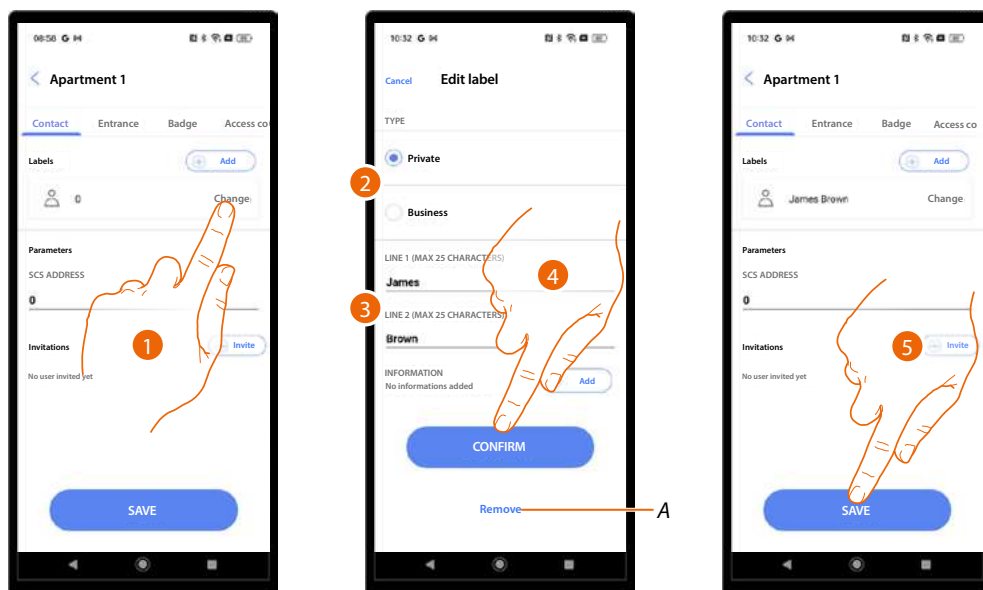

1. Touch to edit a resident.
2. Edit the type of resident.
3. Change the identification details according to resident type.
- A *Delete the resident (only Address book call type).*
4. Touch to confirm.
5. Touch to save.



Invite a resident

This procedure allows a resident to use the Home+Security app to.

- Open the door lock via Bluetooth.
- Manage the own apartment labels (add/remove/change) via Bluetooth, or remotely if the EP is connected.
- Manage the numeric access codes (to open the lock) and the temporary access codes via Bluetooth or remotely, if the EP is connected.

To do this, it will be necessary to enter the resident's e-mail and start the procedure. The resident will receive an email with a link that when clicked requires access to the Home+Security app.

This will associate the security account with that apartment.

It is also possible to send several **invitations at the same time** using the appropriate procedure.

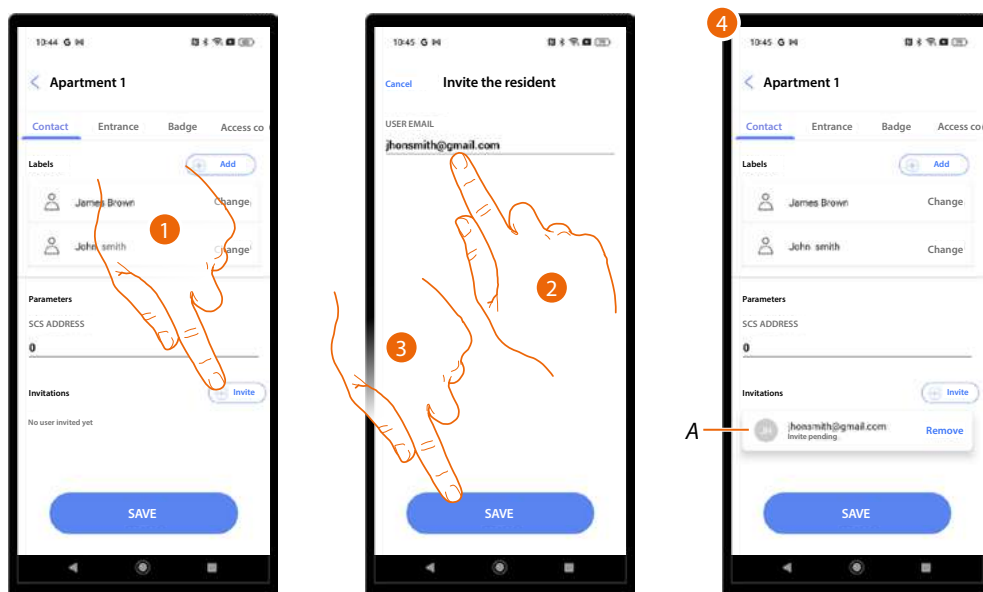

1. Touch to invite a resident.
2. Enter the resident mail.
3. Touch to save.
4. The invitation has been sent and is waiting to be accepted (A).

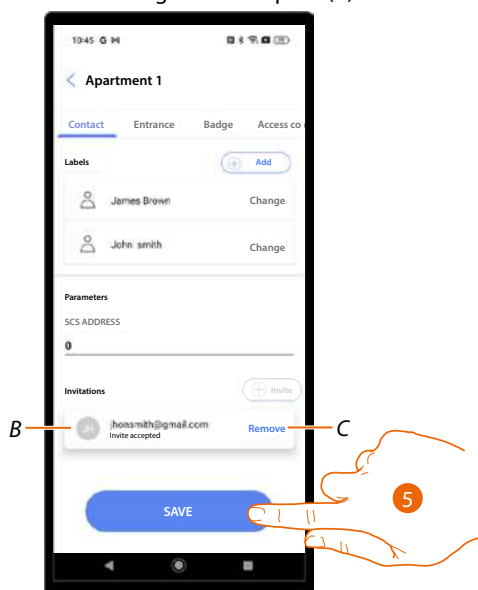

B Once the resident has accepted the invitation, the status is updated.

C Remove the invitation.

5. Touch to save.

Invite several residents at the same time

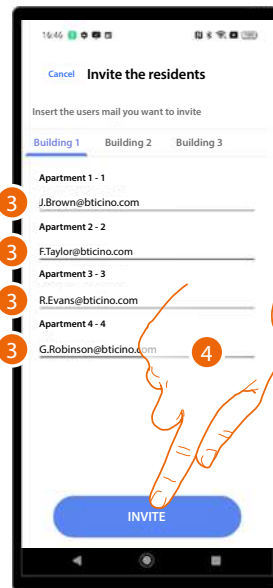
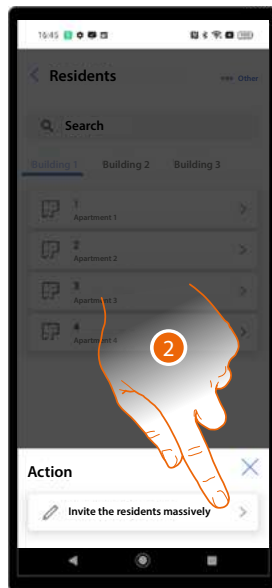
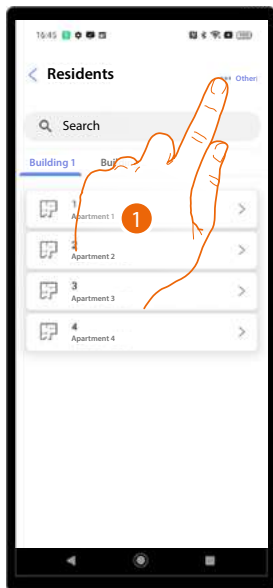

1. Touch to select the function.
2. Touch to start the procedure.
3. Enter the e-mails of the residents to invited for the concerned apartments.
4. Touch to forward the invitations.

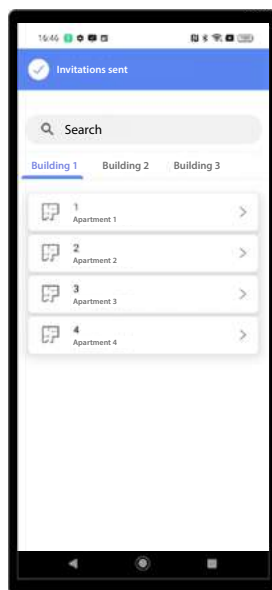

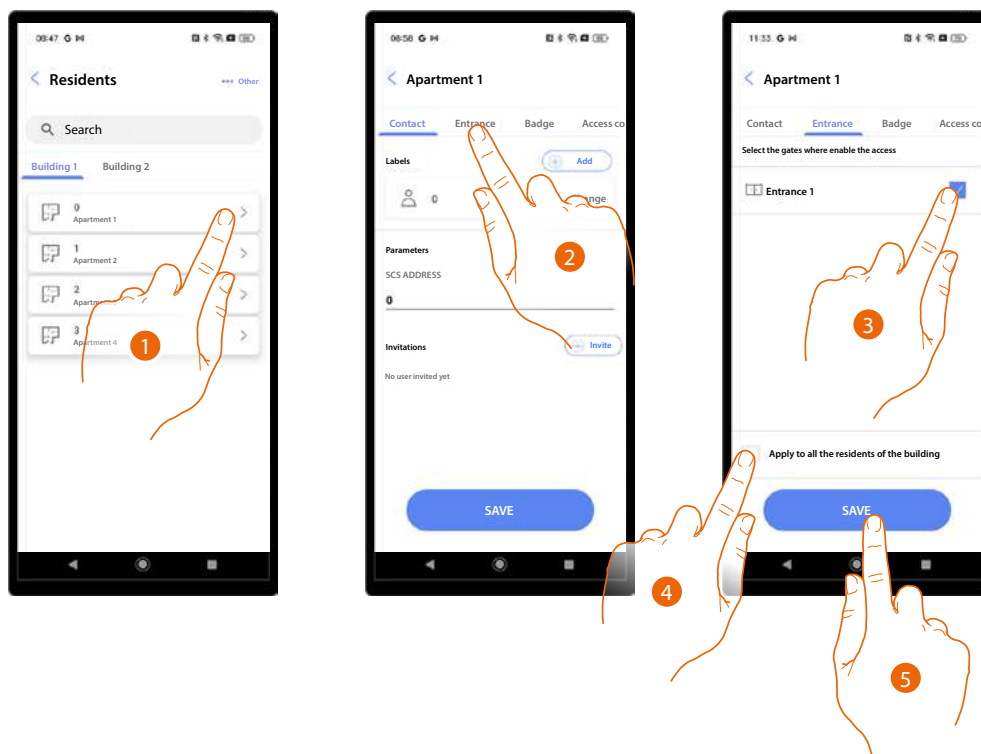
Input

1. Touch to open the apartment management pages.
2. Touch to open the Entrance page.
3. Select the entrance to associate with this apartment.
4. Enable if you want these settings to apply for all the residents of the building.
5. Touch to save.



Badge

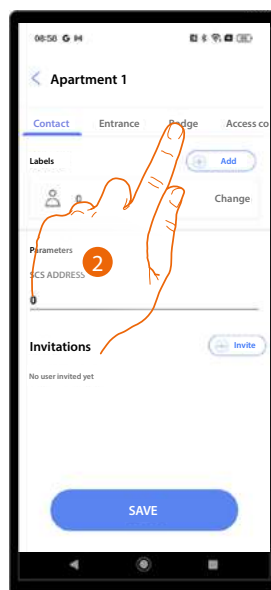
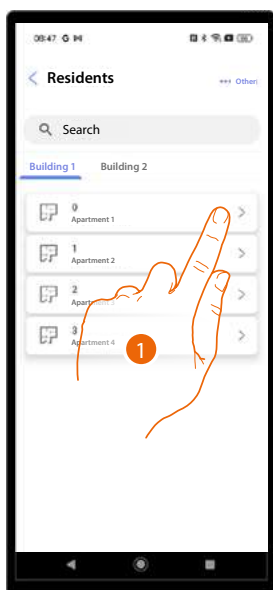

1. Touch to open the apartment management pages.
2. Touch to open the Badge page.
3. Touch to add the badges.

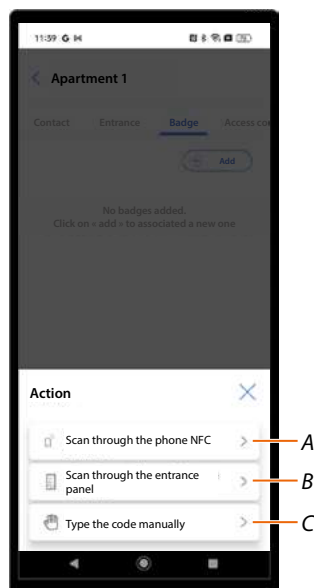

- A ***Associate the badge by reading it using the smartphone NFC sensor.***
- B ***Associate the badge by reading it using the EP RFID badge reader.***
- C ***Associate the badge by entering its code.***



Associate the badge by reading it using the smartphone NFC sensor

This function requires a smartphone that supports NFC connection, which must be enabled.

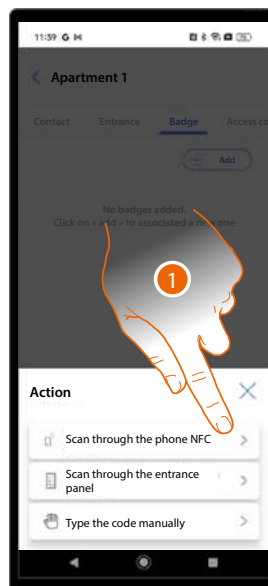

1. Touch to start the procedure.

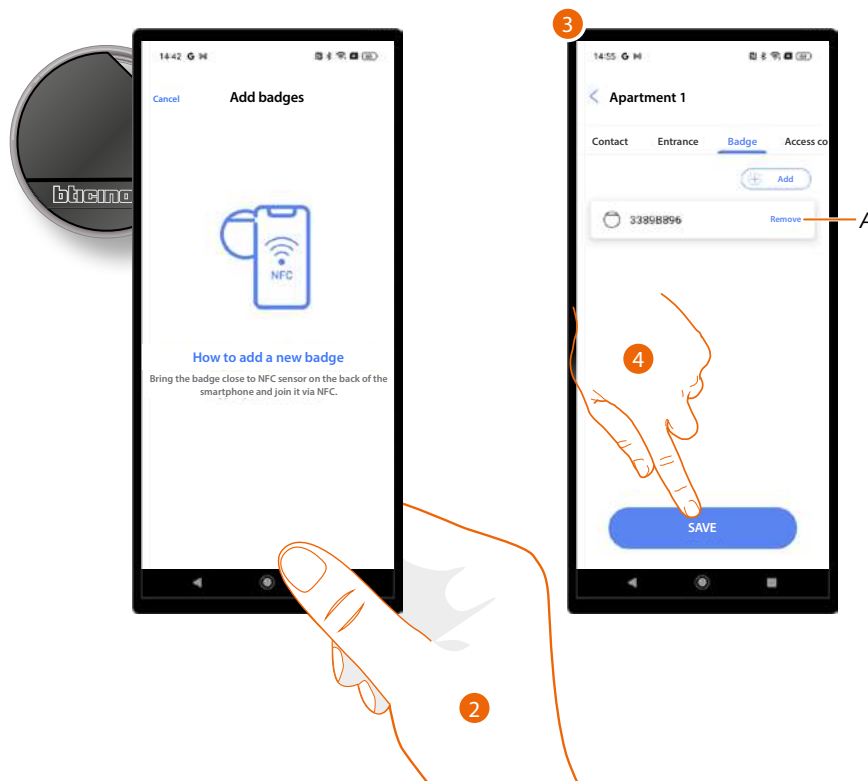

2. Place the badge underneath the smartphone.
3. The badge has been added and associated with the apartment.
- A *Delete the badge association.*
4. Touch to save.



Associate the badge by reading it using the EP RFID badge reader

To use this function, the EP must be associated with the app.

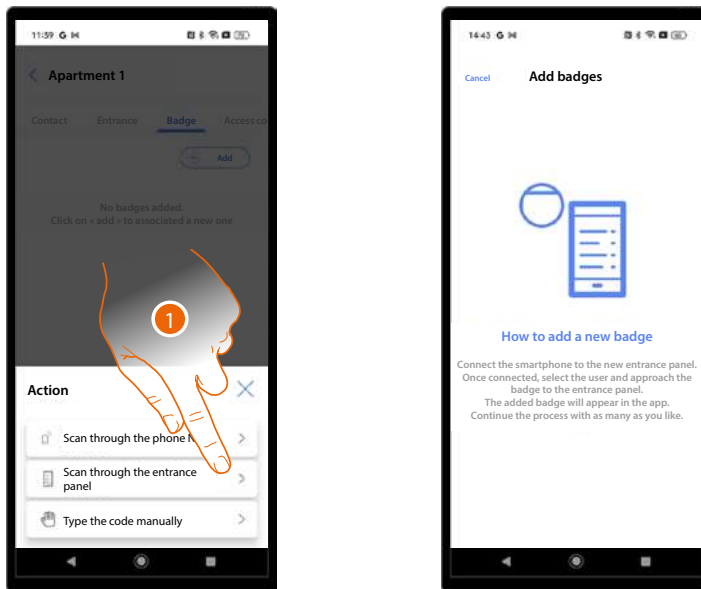

1. Touch to start the procedure.

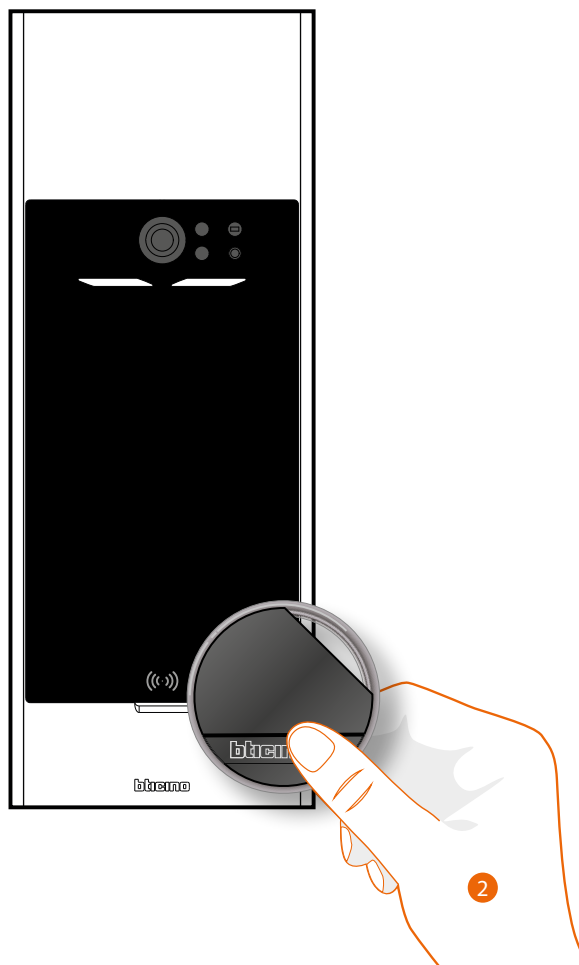

2. Place the badge in front of the EP in correspondence with the RFID reader.



3. The badge has been added and associated with the apartment.
- A Delete the badge association.
4. Touch to save.

Associate the badge by entering its code

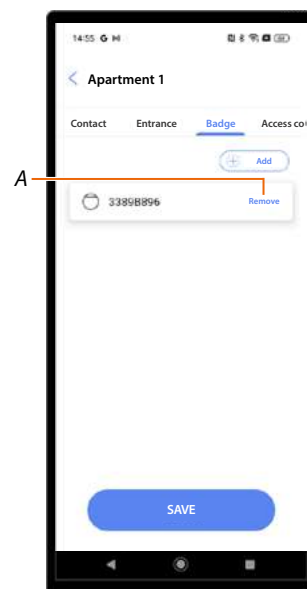
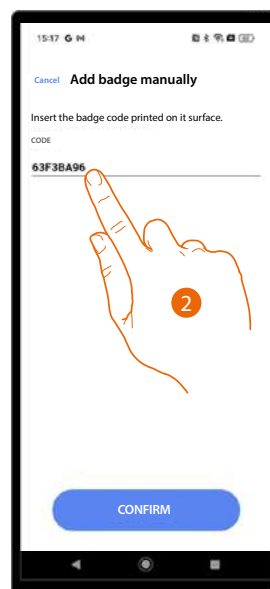
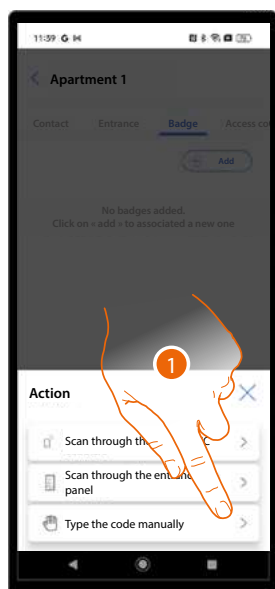

1. Touch to start the procedure.
2. Enter the code on the back of the badge.
3. The badge has been added and associated with the apartment.
- A Delete the badge association.
4. Touch to save.



Access code

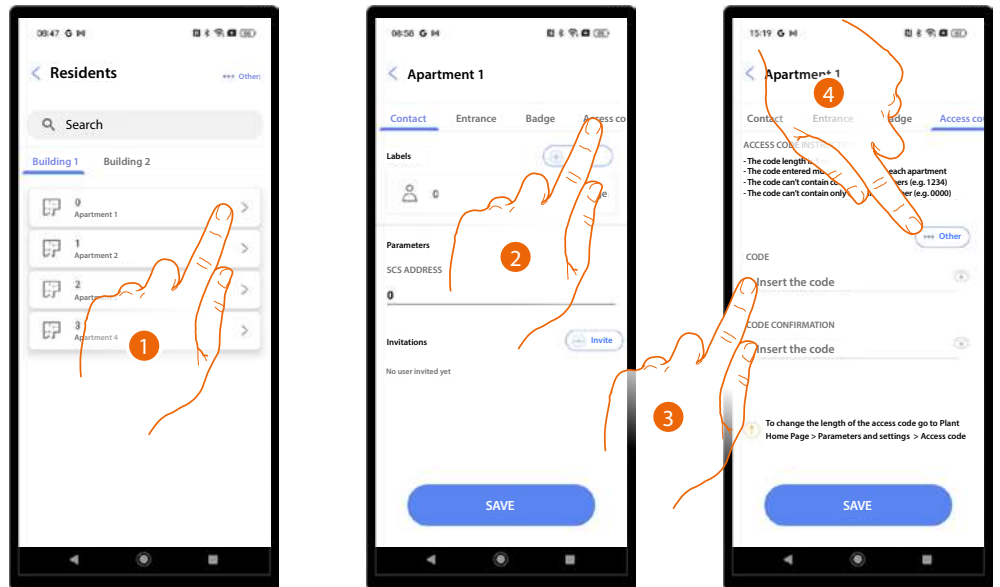

1. Touch to open the apartment management pages.
2. Touch to open the access code page.
3. Enter a code with the following features
 - Length 5 digits (you can change this option in the [parameters/access code](#))
 - It is possible to use only numbers.
 - It must be different from those of other apartments.
 - It must not consist of consecutive numbers (e.g. 12345).
 - It must not contain the same number for all digits (e.g. 00000).
4. Alternatively, the code may also be generated automatically; touch to start the procedure.

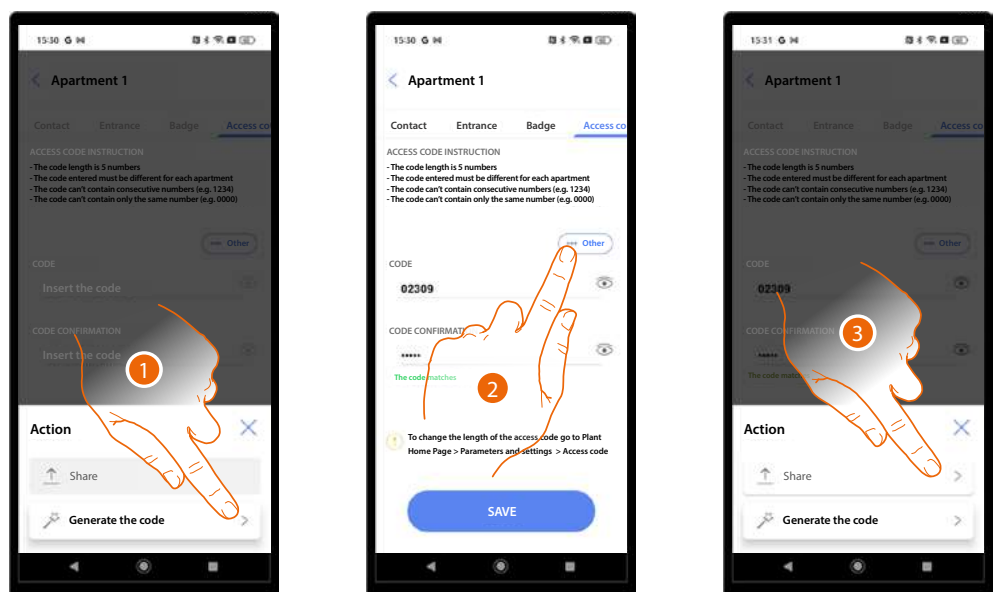

1. Touch to generate the code.
2. The code can also be shared in several ways.
3. Touch to share the code.

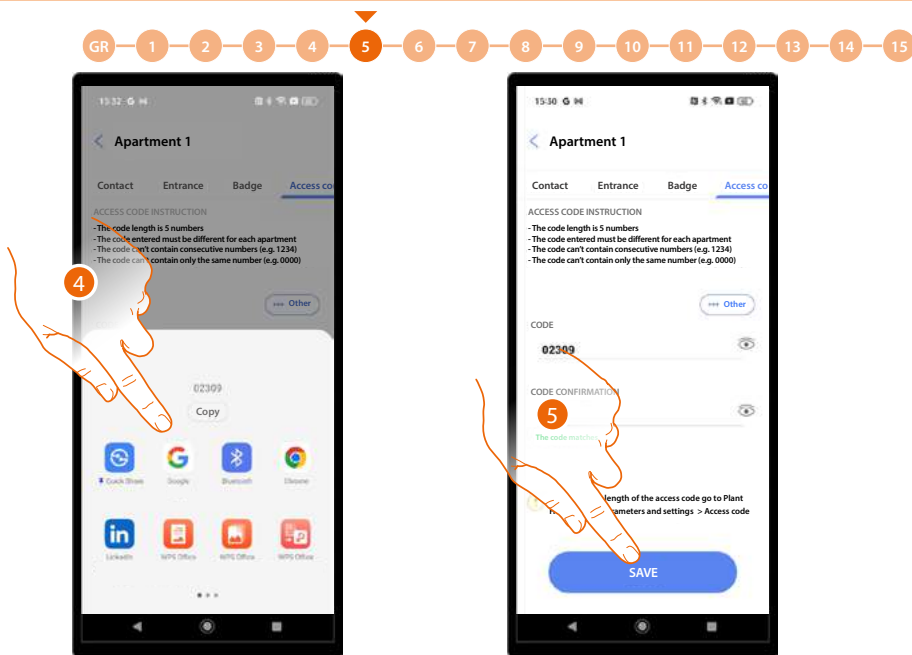

4. Select the type of sharing.
5. Touch to save.

Badge

This section can be used to manage all the system badges created in the individual apartments, or to create new ones.

When creating badges in this section, you can decide to assign them to residents or staff (temporary or periodic).

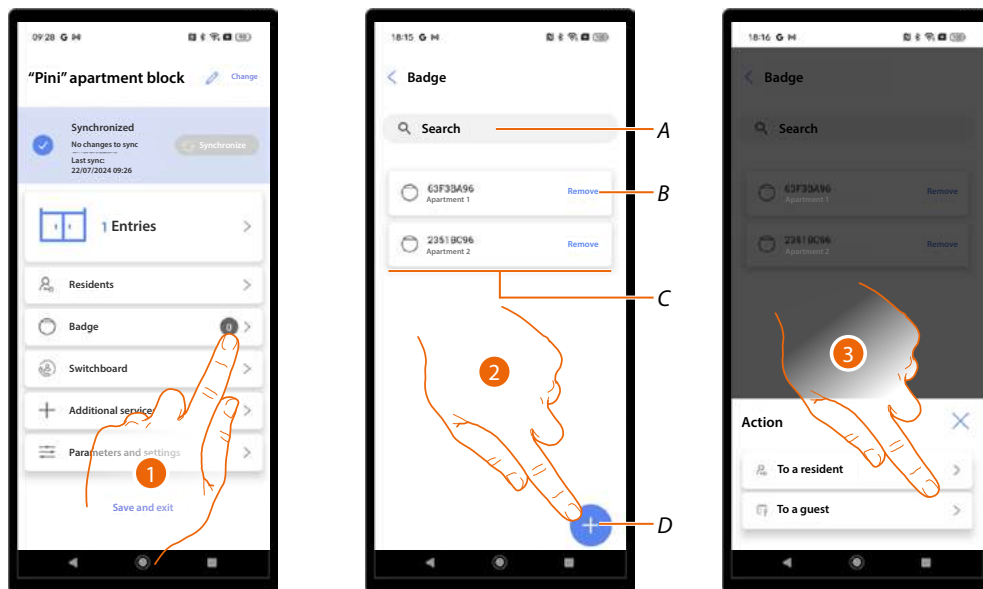

1. Touch to open the Badge section.
- A *Badge search by badge number or apartment name.*
- B *Remove badge association.*
- C *Associated badges.*
- D *Add a badge.*
2. Touch to add a badge.
3. Select the type of badge.

Create a resident badge

These types of badges are linked to an apartment.

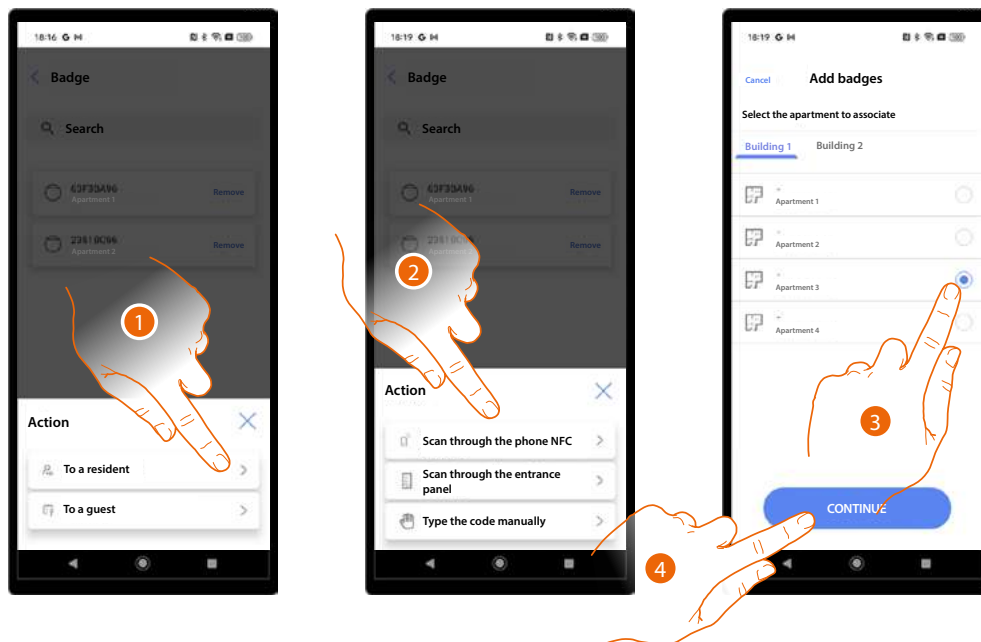

1. Select the type of resident.
2. Select the type of association.
3. Select the apartment.
4. Touch to continue.

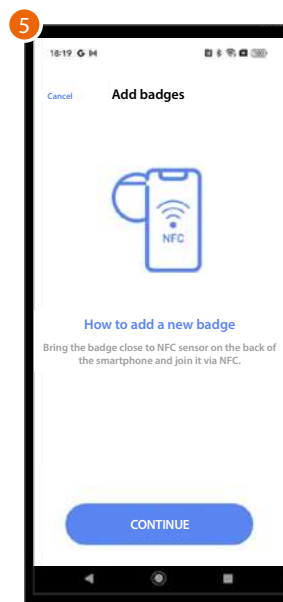

5. Different actions are required depending on the association method (see [residents/badges](#)).

Create a staff badge

The creation of this type of badge is only possible if you have previously created a permanent staff profile (see [additional services/staff](#) for details).

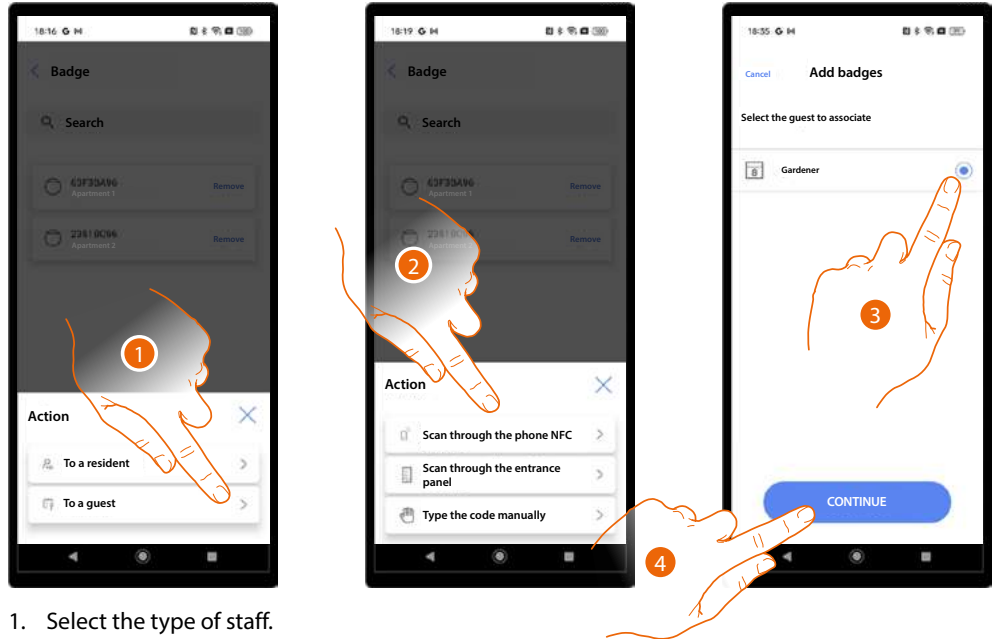

1. Select the type of staff.
2. Select the type of association.
3. Select the staff profile to associate with the badge.
4. Touch to continue.

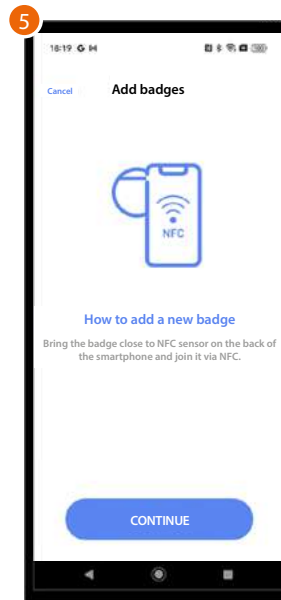

5. Different actions are required depending on the association method (see [residents/badges](#)).



Guard station

This section is used to set the presence of one or more guard stations in the system

NOTE: this function is not available for the "Building Manager" user

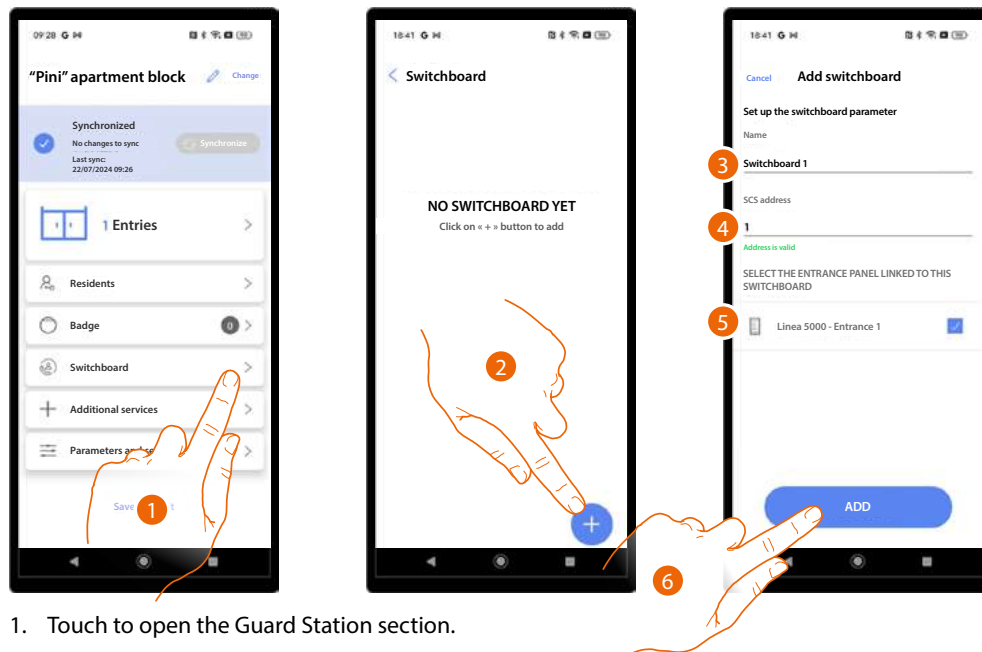

1. Touch to open the Guard Station section.
2. Touch to add a guard station.
3. Set the name.
4. SCS address of the guard station.
5. Select the EPs connected to the guard station.
6. Touch to continue.

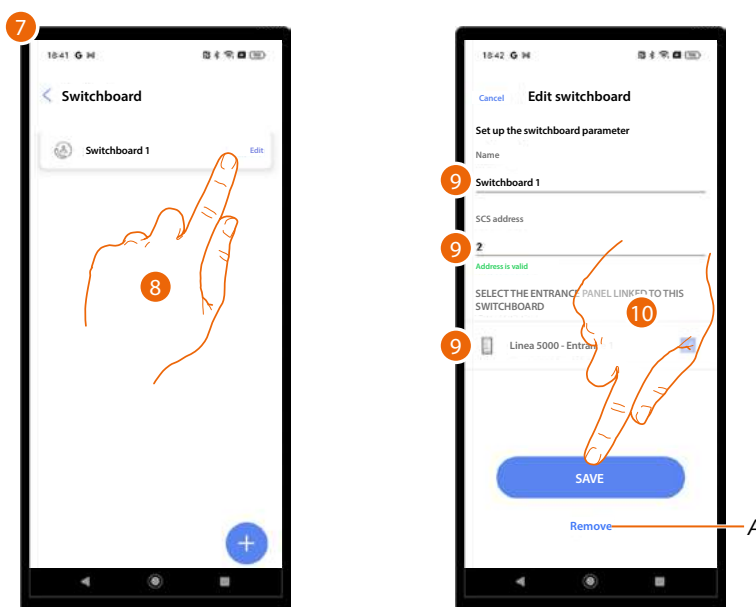

7. The guard station has been created.
8. If necessary touch modify or delete it.
9. Edit the parameters.
- A Delete the guard station.
10. Save the changes.



Additional services

This section can be used to create staff profiles and messages to send to the EP.

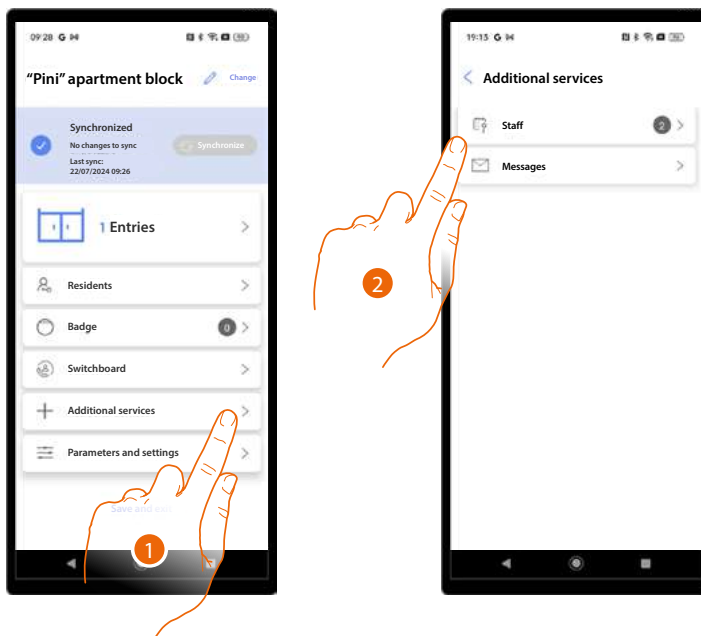

1. Touch to open the Additional services section.
2. Select the service, either **Staff** or **Messages**.



Staff

There are two types of staff profiles:

- **Temporary staff** which can be used to allow entry using a code at a specific date and for a certain period of time.
- **Periodic staff**, which can be used to allow entry using a code or a badge at a specific date (single day or period) repeated regularly for certain days of the week or for a certain period of time.

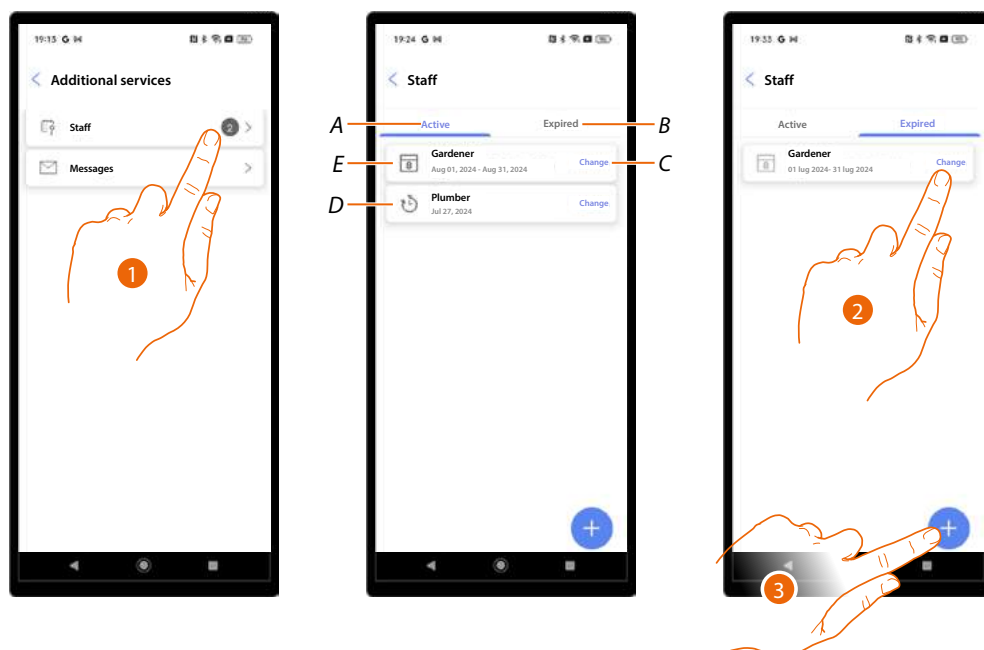

1. Touch to open the staff section.
 - A *Staff zone with authorisations still active.*
 - B *Staff zone with authorisations expired.*
 - C *Modify staff - you can modify all the set parameters or delete the staff member.*
 - D *Temporary staff.*
 - E *Periodic staff.*
2. Touch to modify the parameters of the expired staff member to reactivate them.
3. Touch to add a new staff member.



Temporary staff

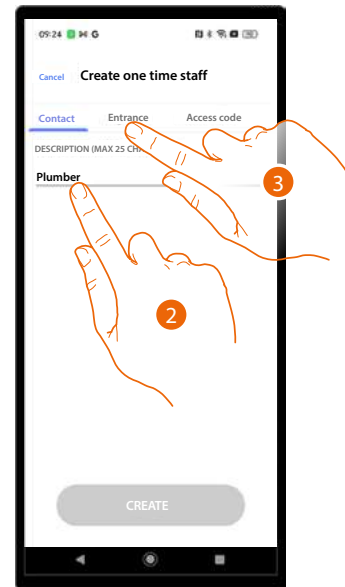
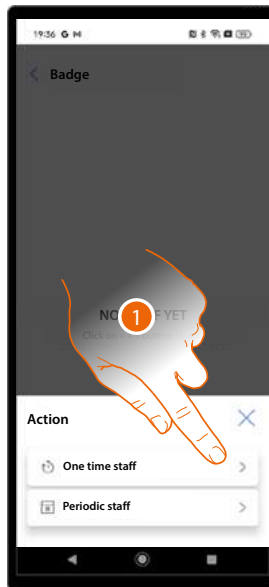

1. Touch to create a temporary staff.
2. Enter a name.
3. Touch to set the entrance conditions.

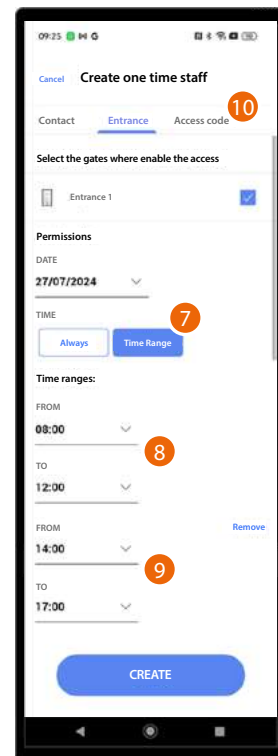
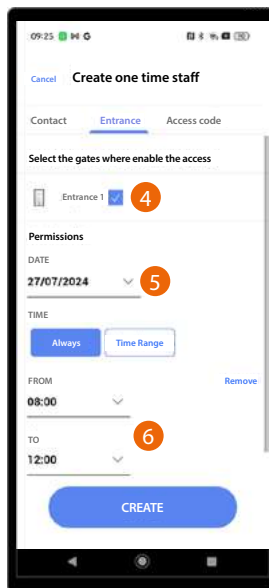

4. Touch to select the entrances to enable for this staff member.
5. Touch to set a date.
6. Touch to set a time period (e.g.: entry permitted to plumbing staff on 27/07/2024 from 8 a.m. to 12 noon).
- Or
7. Touch to set a time range.
8. Touch to set the first period.
9. Touch to set the second period (e.g.: entry permitted to plumbing staff on 27/07/2024 from 8 a.m. to 12 noon and from 2 p.m. to 5 p.m.)
10. Touch to set the code.

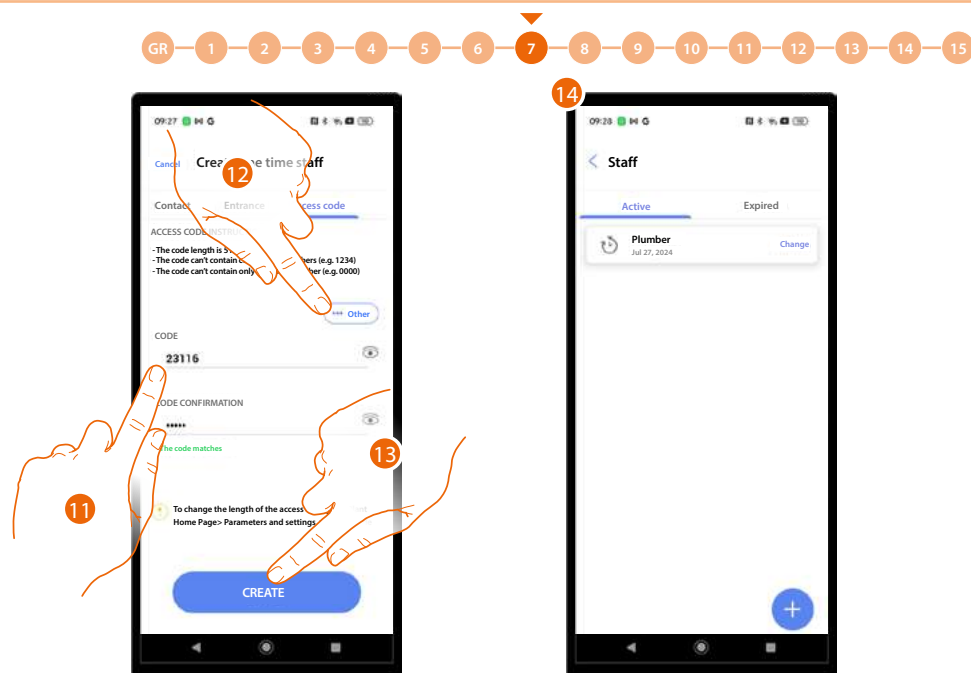

11. Enter a code with the following features
 - Length 5 digits (you can change this option in the [parameters/access code](#) menu
 - It is possible to use only numbers.
 - It must be different from those of other apartments
 - It must not consist of consecutive numbers (e.g. 12345)
 - It must not contain the same number for all digits (e.g. 00000)
12. Alternatively, the code may also be generated automatically; touch to start the procedure.
13. Touch to end.
14. The temporary staff has been created.

Regular staff

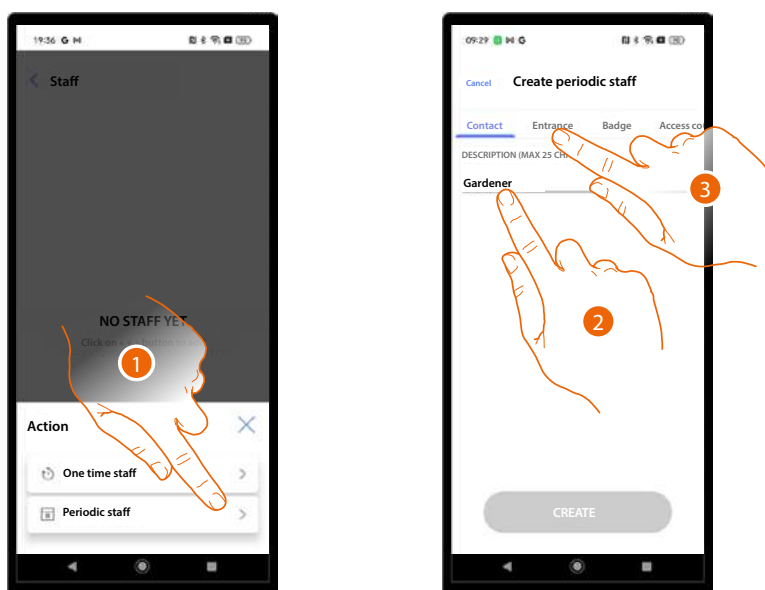

1. Touch to create a temporary staff.
2. Enter a name.
3. Touch to set the entrance conditions.

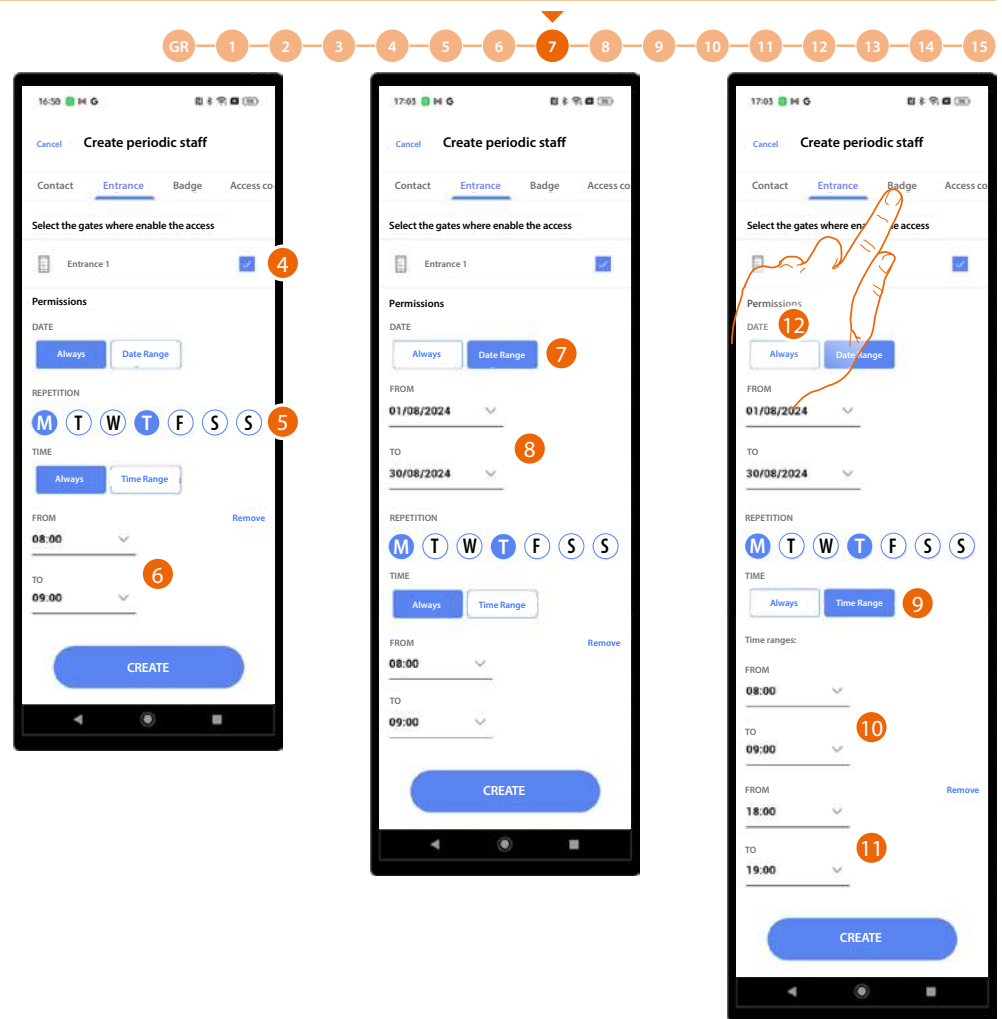

4. Touch to select the entrances to enable for this staff member.
 5. Touch to set the days of the week on which to allow entry.
 6. Touch to set a time period (e.g.: entry permitted to gardening staff on Mondays and Thursdays from 8 a.m. to 9 a.m.).
- Or
7. Touch to set a range of days.
 8. Touch to set the start and end of the period.
(e.g.: entry permitted to gardening staff on Mondays and Thursdays from 8 to 9 a.m., in August only)
- Or
9. Touch to set a time range.
 10. Touch to set the first period.
 11. Touch to set the second period (e.g.: entry permitted to gardening staff on Mondays and Thursdays from 8 a.m. to 9 a.m. and from 6 p.m. to 7 p.m., in August only).
 12. Touch to display the Badge section.



Set the badge

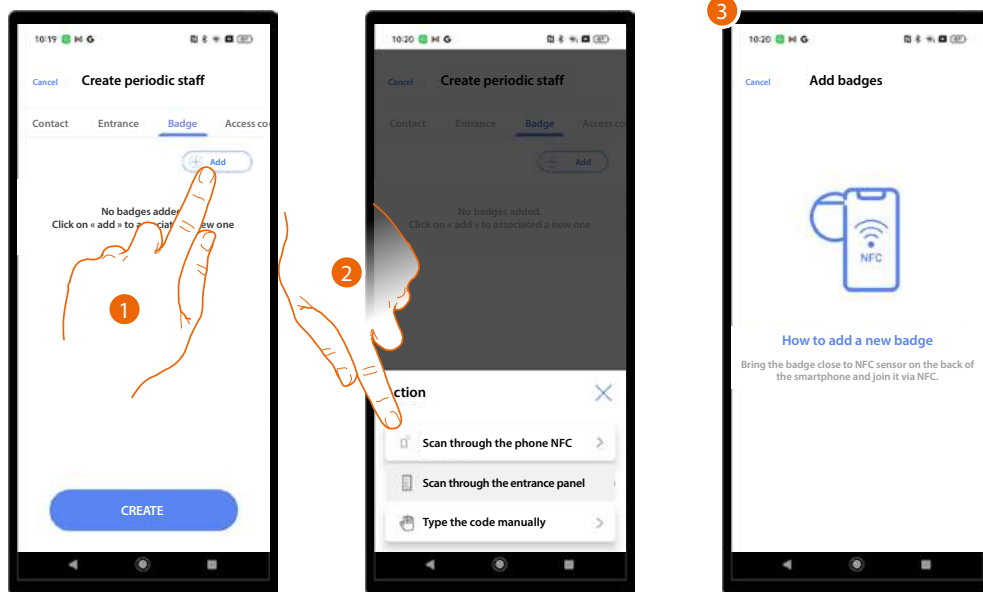

1. Touch to create the badge.
2. Select the type of association.
3. Different actions are required depending on the association method (see [residents/badges](#)).



4. The badge has been created; touch to associate a staff access code.

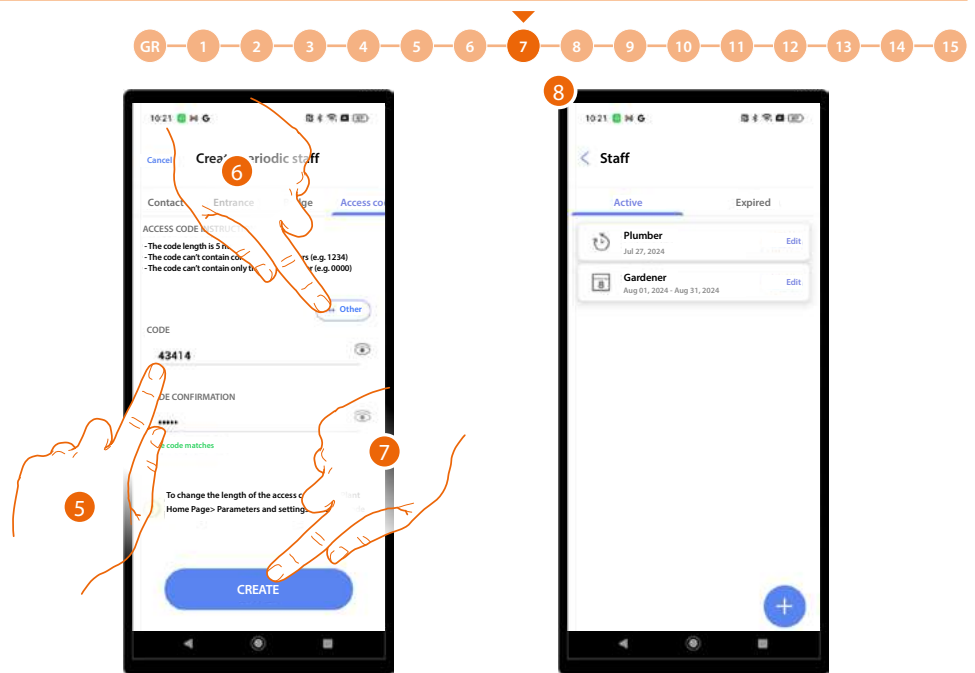

5. Enter a code with the following features
 - Length 5 digits (you can change this option in the [parameters/access code](#) menu)
 - It is possible to use only numbers.
 - It must be different from those of other apartments.
 - It must not consist of consecutive numbers (e.g. 12345).
 - It must not contain the same number for all digits (e.g. 00000).
6. Alternatively, the code may also be generated automatically; touch to start the procedure.
7. Touch to end.
8. The periodic staff has been created.



Messages

This section can be used to create messages that will appear on the display of the EPs.

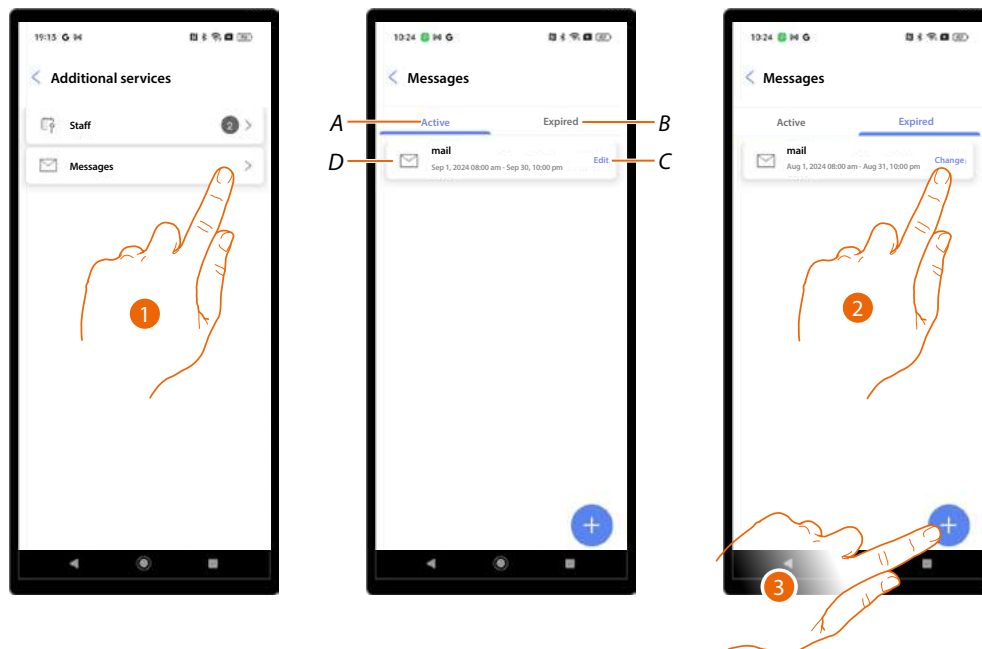

1. Touch to open the Messages section.
- A Active messages.
- B Expired messages.
- C Edit a message.
It is possible to edit all the set parameters or delete the message.
- D Message.
2. Touch to edit the parameters of an expired message and reactivate it.
3. Touch to create a new message.

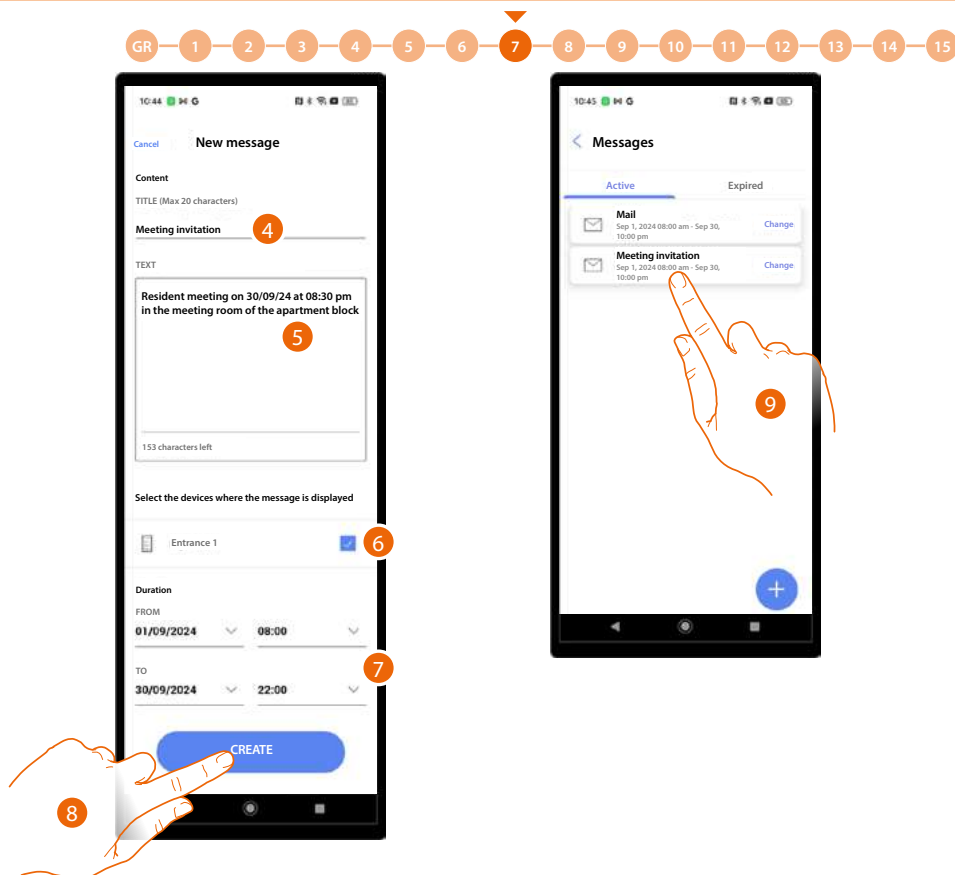

4. Enter a title for the message.
5. Enter a text.
6. Select the EPs in which the message will appear.
7. Set the time period during which it will be active.
8. Touch to create the message.
9. The message has been created.

Parameters and settings

In this section it is possible to configure different device parameters.

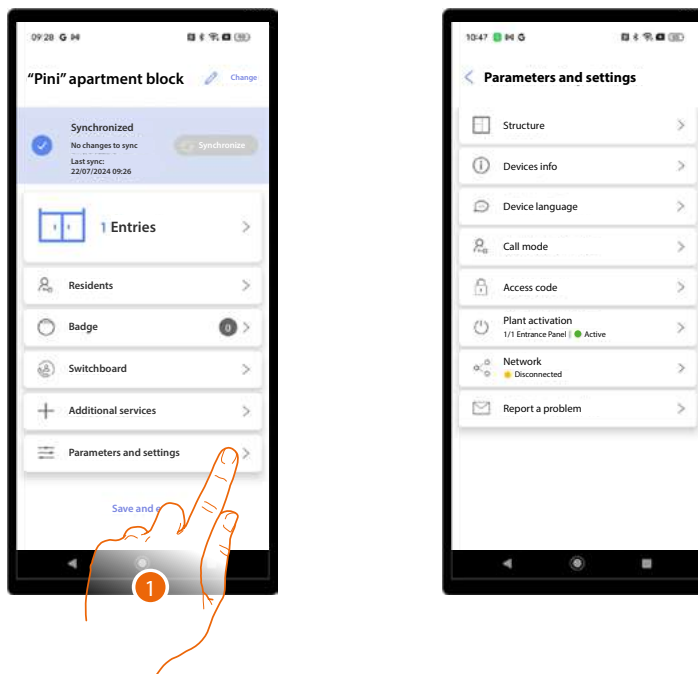

1. Touch to open the page.

Function	Description
Structure*	Modifies the structure created during the initial system configuration
Device Info	Displays some system device data
Select the language	Selects the device language
Call Mode	Changes some call mode parameters
Access codes	Changes the access code length and enables the Paspartout code
System activation*	Activates/deactivates the system devices
Network	Connects the device to a network to allow remote modifications
Send problem	Reports a problem to the after-sales service and sends a log

***NOTE:** Function not available for the "Building manager" user.

Structure

This section can be used to modify the structure created during the initial system configuration. Depending on the type of call set up, the pages will have a different appearance and content.

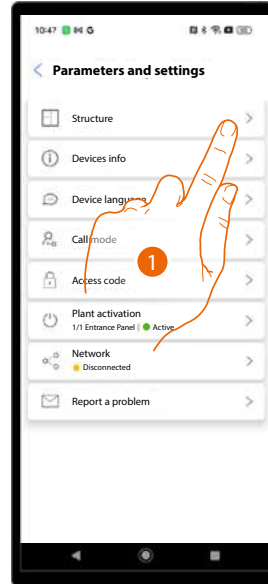

1. Touch to open the page.

Call using the Address book

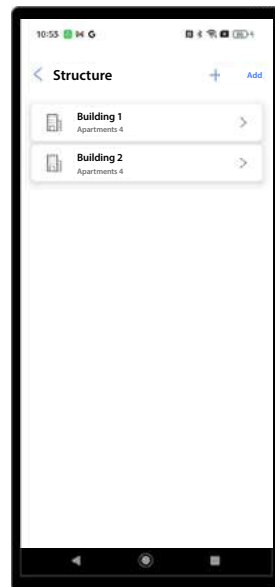

It is possible to edit or create new buildings, apartments.
The methods are the same as those shown in:
[System creation and first configuration/Address book](#)

Call using a Code

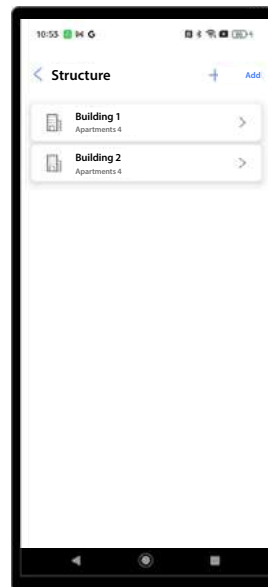

It is possible to edit or create new buildings, apartments.
The methods are the same as those shown in:
[System creation and first configuration/Code](#)

Call using Block/Riser/
Floor/Apartment



It is possible to edit or create new buildings, Risers, floors and apartments.
The methods are the same as those shown in:
[System creation and first configuration/Block/Riser/Floor/Apartment](#)

Device info

This section can be used to display some system device data

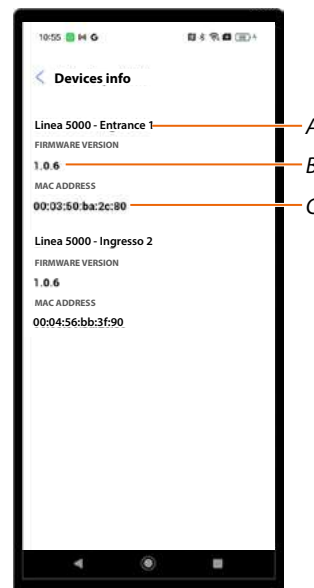
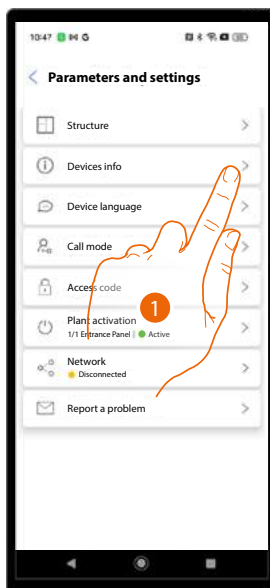

1. Touch to open the page.

A Name of the device.

B Firmware version.

C MAC address.

Select the language

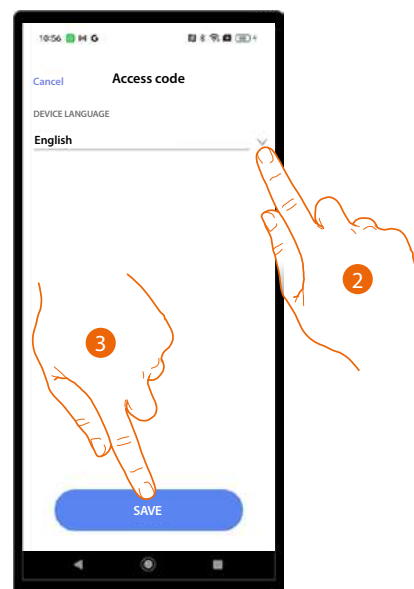
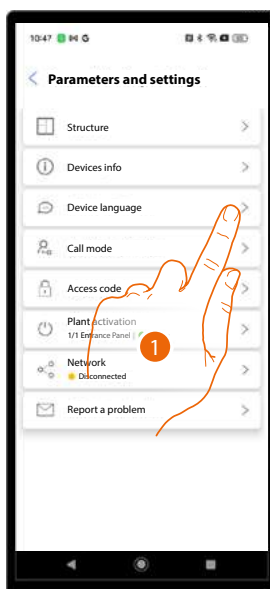

1. Touch to open the page.

2. Select the device language.

3. Touch to save.

Call modes

In this section, it is possible to edit some call mode parameters.

Depending on the type of call set up, the pages will have a different appearance and content.

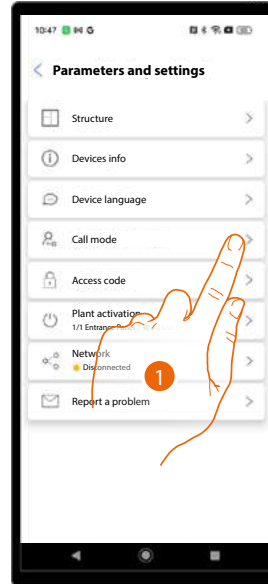

1. Touch to open the page.

Call using the Address book

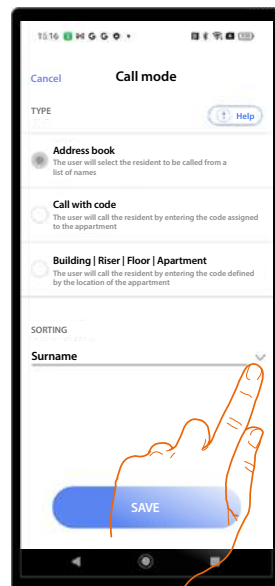

Touch to change the sorting of residents in the address book of the EP. You can sort them by surname or by apartment.

Call using a Code

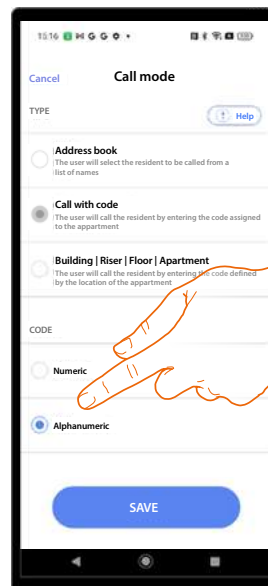

Touch to edit the type of code, numeric or alphanumeric.

Call using Block/Riser/ Floor/Apartment

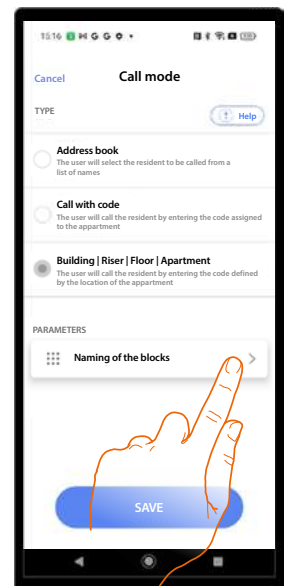

Touch to change the designation of buildings, risers, floors and apartments, using numbers or letters.

Access code

This section can be used to change the length of the access code and enable the Passepartout code, which allows to have a unique code to open all apartments.

Set the same code for the whole system

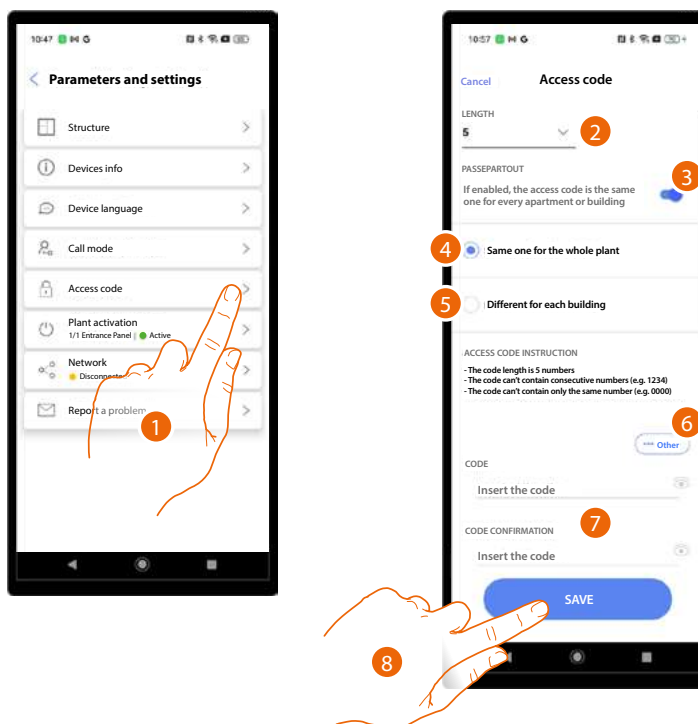

1. Touch to open the page.
2. Touch to set the code length.
NOTE: function not available for the "Building manager" user.
ATTENTION: when changing the length, all previously entered codes will be deleted because they no longer meet the length requirement.
3. Touch to enable the Passepartout function.
4. Touch to set the same code for the whole system.
5. Touch to set the **same code for the each building**.
6. Touch to automatically generate the code and/or share it.
7. Enter the Passepartout code manually.
8. Touch to save.

Set the same code for the each building

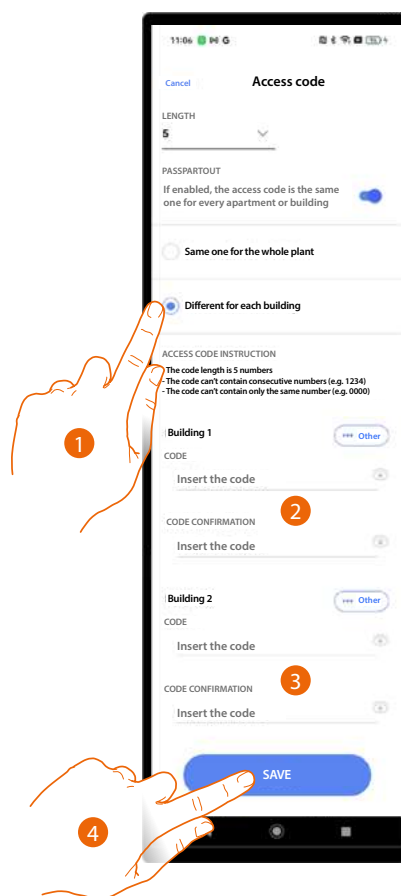

1. Touch to select the function.
2. Touch to set the code for building 1
3. Touch to set the code for building 2
4. Touch to save.

System activation

***NOTE:** function not available for the "Building manager" user.

This section can be used to enable/disable the system devices.

In order to be considered active, the system must have completed the configuration of all EPs selected as active on this page.

Inactive devices appear as if they are not physically present in the system and, therefore, will not receive address book updates through the automatic synchronisation function.

The function can be useful, for example, in cases where new entrances and corresponding EPs are required, to be activated later.

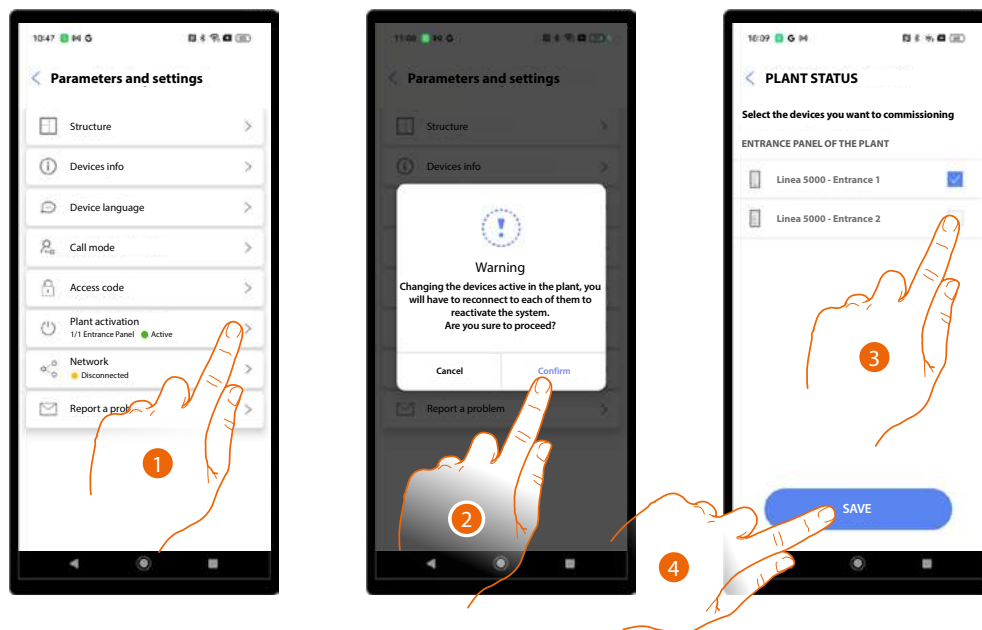

1. Touch to open the device activation page.
2. To activate the devices, they must be reconnected to the system; touch to continue.
3. Touch to activate the inactive device.
4. Touch to save.

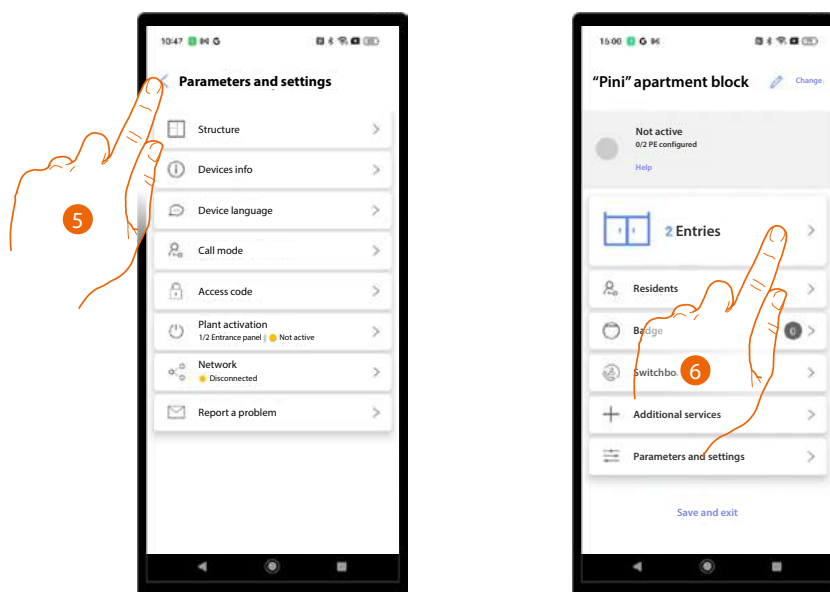

5. Return to the Home Page.
6. The EP must now be activated; touch to open the entrance section.

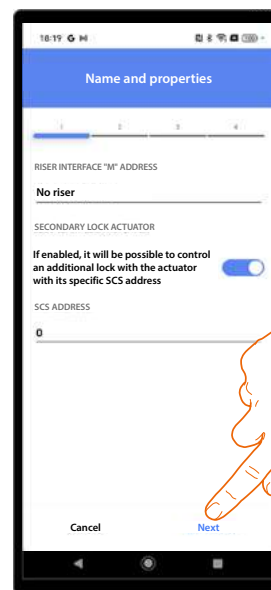
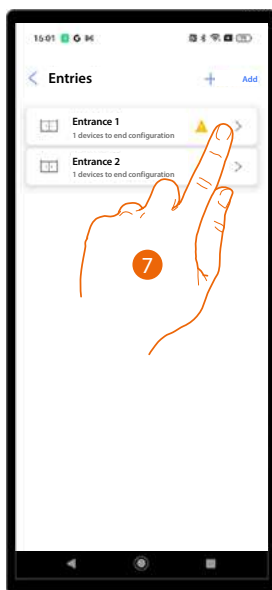

7. Touch to send the configuration to the EP added during the system creation and first configuration.
8. Confirm or modify the parameters and resend the configuration to the EP; see [System creation and first configuration/set parameters.](#)

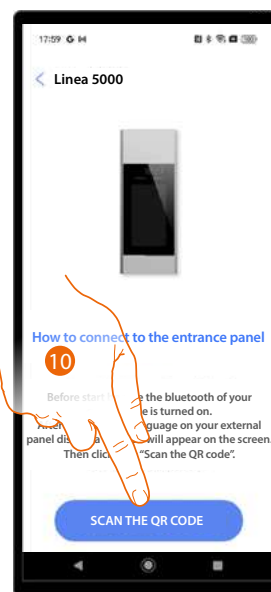
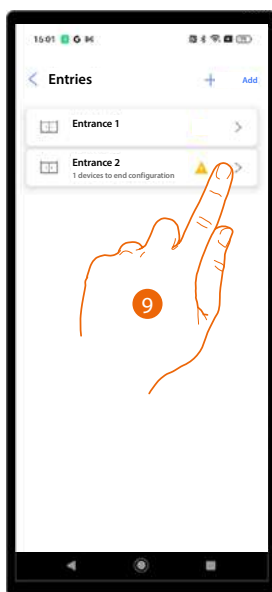

9. Touch to configure the EP added later.
10. Perform the complete association; see [System creation and first configuration.](#)

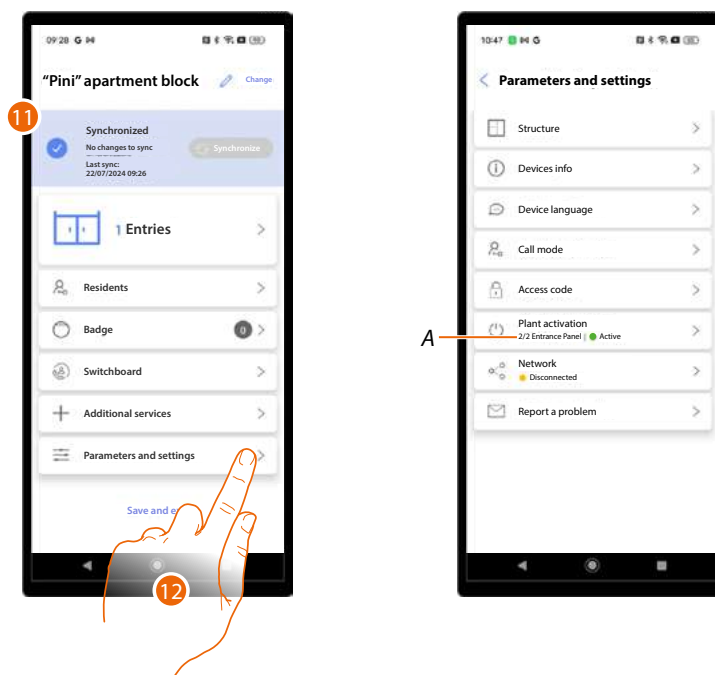

11. When finished, the Home Page appears, indicating that the system is synchronised.

12. Touch to open the Parameters and Settings page again, which will show that both EPs are active (A).



Network

This section can be used to connect the device to a network (**Wi-Fi** or **Ethernet**). The connection to the network allows the configuration to be completed remotely. Not all configurations can be completed remotely: if remote configuration is not possible, a message alerts the user by asking to stand close to the device and send any changes manually via Bluetooth connection.

Connection through Wi-Fi network

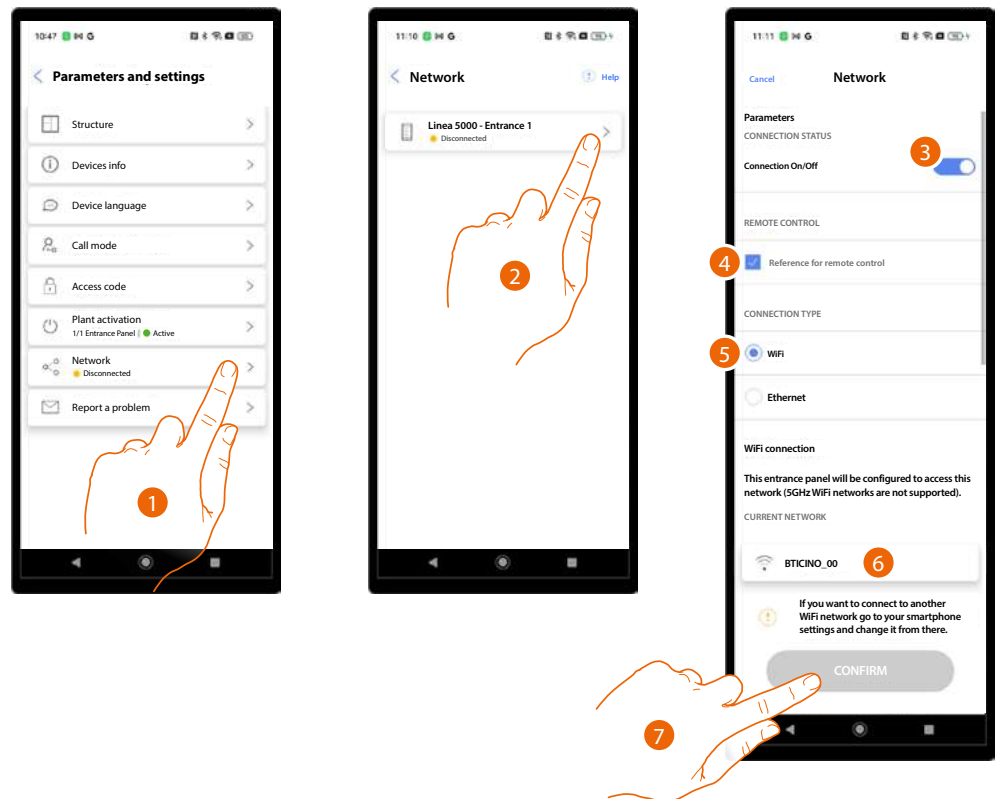

1. Touch to open the network setting page.
2. Touch to connect the EP.
3. Touch to enable the connection.
4. Touch to set this EP as the referent for remote connection. The EP set as referent will then forward all modifications to the other system EPs.
NOTE: By default, this option is already selected for the first EP connected.
5. Select the Wi-Fi connection.
6. This displays the network to which the smartphone is currently connected (this stage requires connection to a Wi-Fi network).
7. Touch to continue.

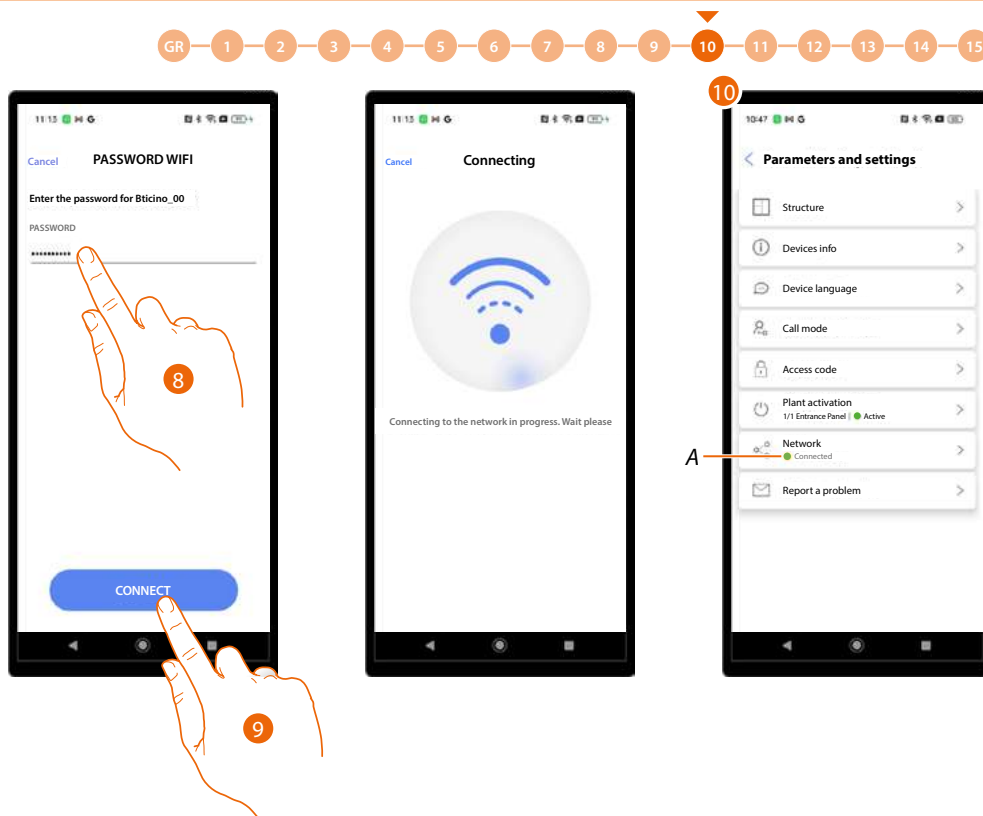

8. Touch to enter the network password.
9. Touch to continue.
10. The EP is connected (A).



Connection through Ethernet network

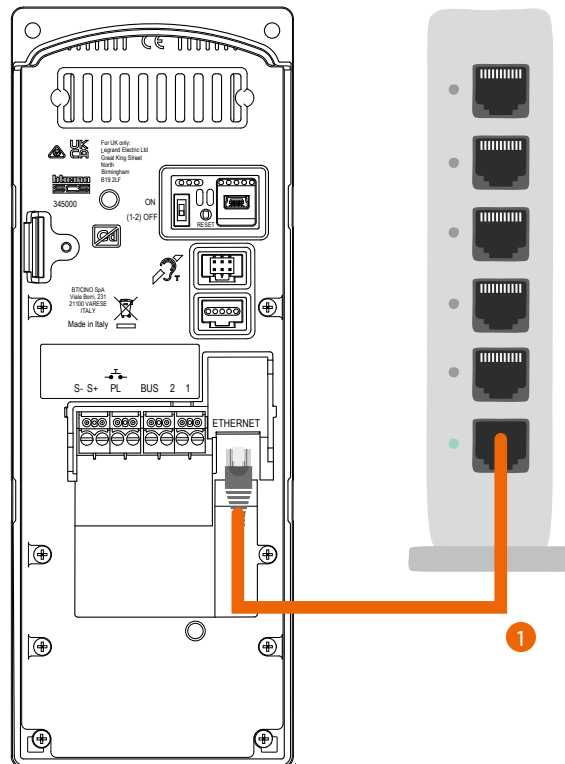

1. Connect the EP to the network using a network cable.

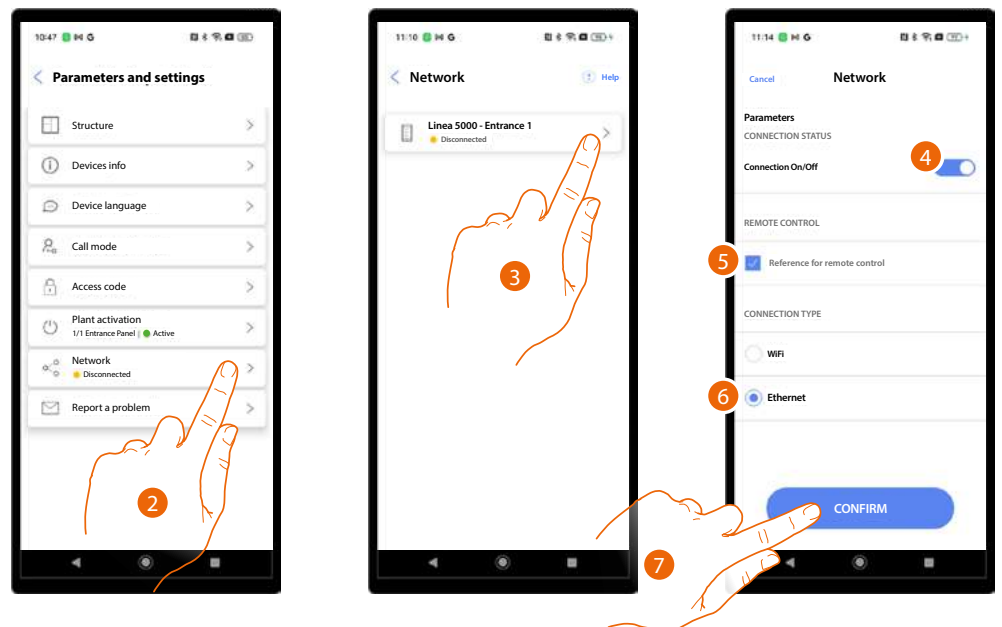

2. Touch to open the network setting page.
3. Touch to connect the EP.
4. Touch to enable the connection.
5. Touch to set this EP as the referent for remote connection. The EP set as referent will then forward all the modifications to the other system EPs.
NOTE: by default, this option is already selected for the first EP connected.
6. Select the Ethernet connection.
7. Touch to continue.

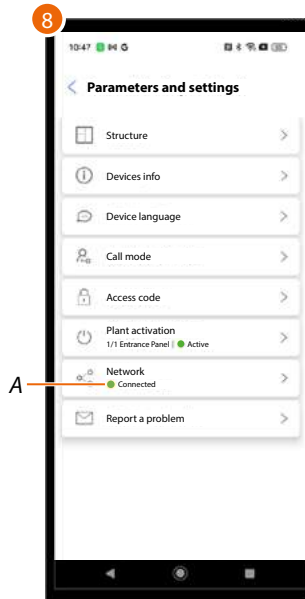

8. The EP is connected.

Send problem details

This section can be used to report a problem to the after-sales service and send recorded logs directly from the device via Bluetooth.

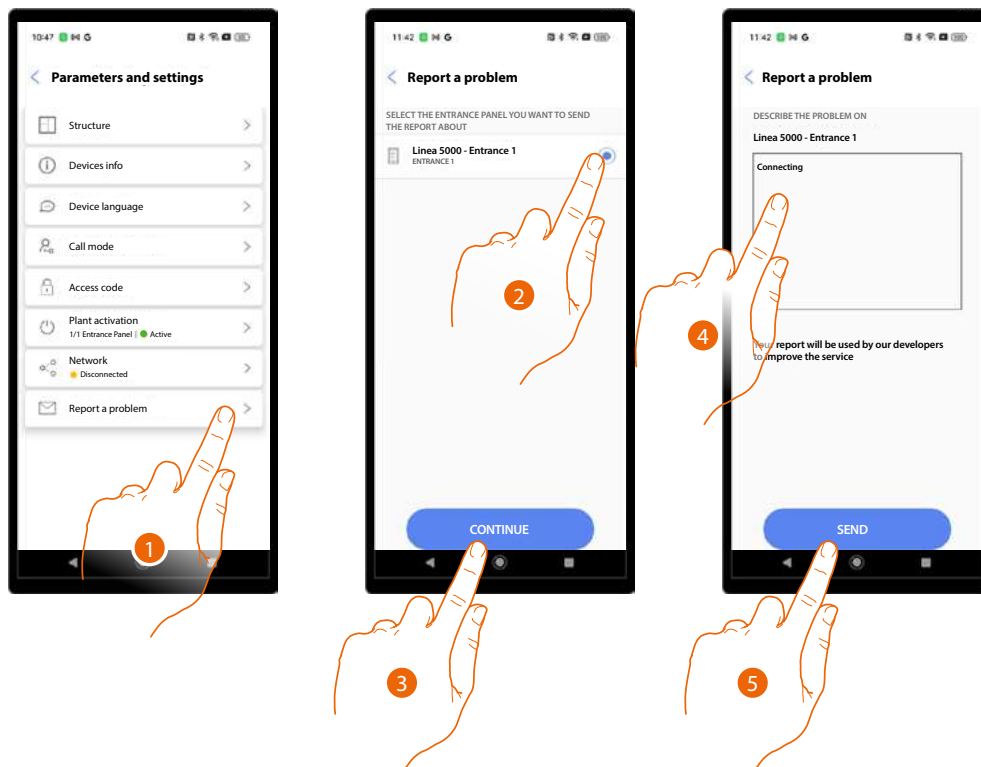

1. Touch open the notification page.
2. Select the EP with the problem.
3. Touch to confirm.
4. Insert a description message.
5. Touch to send.

Configurations from device

It is possible to set **some device settings** and perform a **device reset**.

Device settings

To display this page on the device, it is necessary to complete the **Entrances/show settings on the device** procedure.

Call test

This function allows communication with an IU and adjustment of speaker and microphone volume.

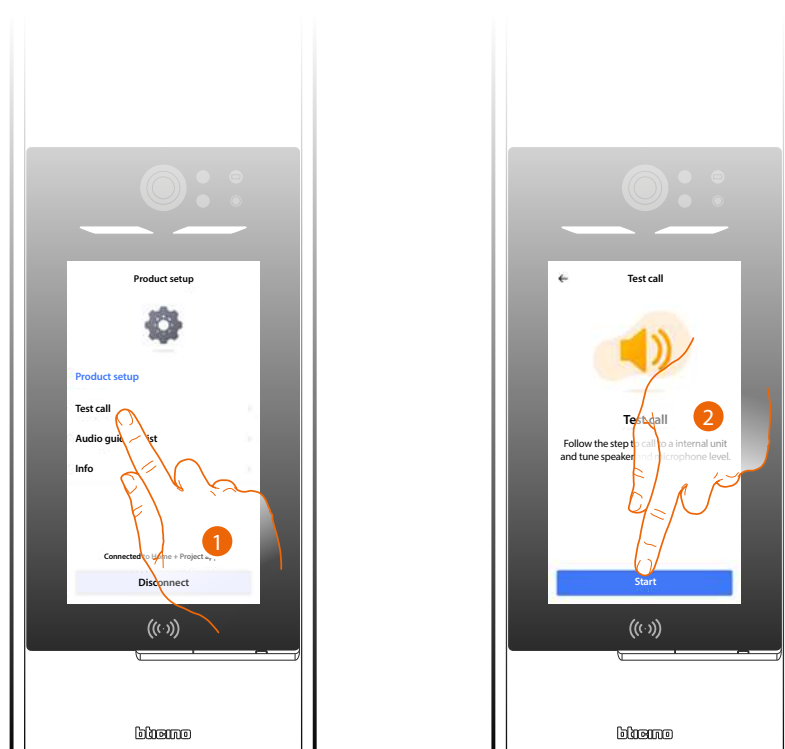

1. Touch to select the function.
2. Touch to start.



3. Enter the SCS address of the IU.
4. Touch to send the call.
5. Listen to the audio, talk to the IU and adjust as necessary.
6. Touch to end.

Volume setting

This function can be used to adjust the volume of the voice guidance that generates the messages.

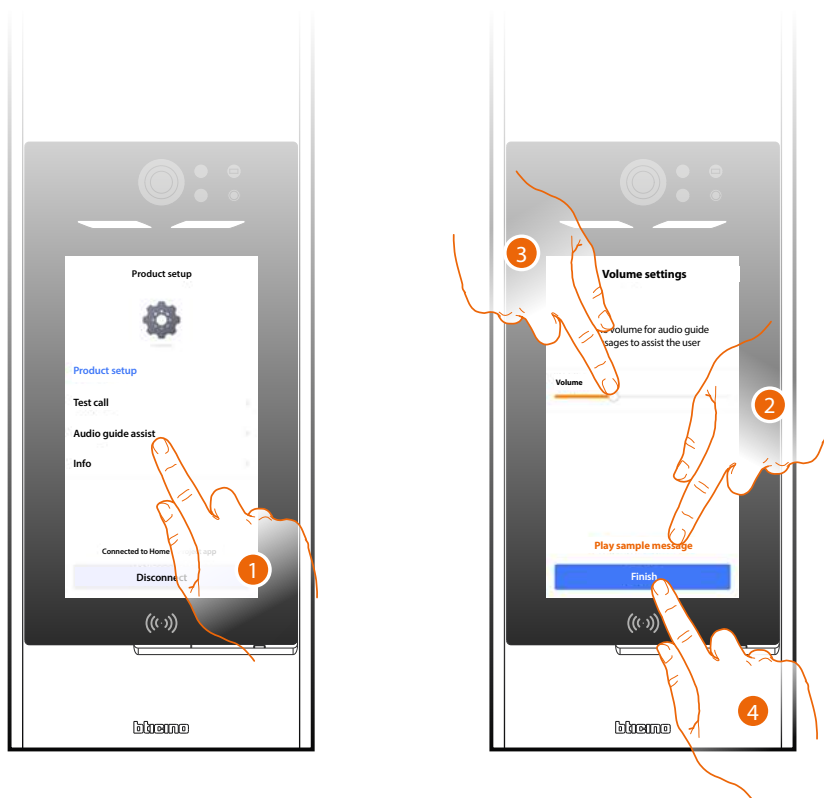

1. Touch to select the function.
2. Touch to play a test message.
3. Adjust the volume if necessary.
4. Touch to end.

Device info

This function can be used to view certain EP data.

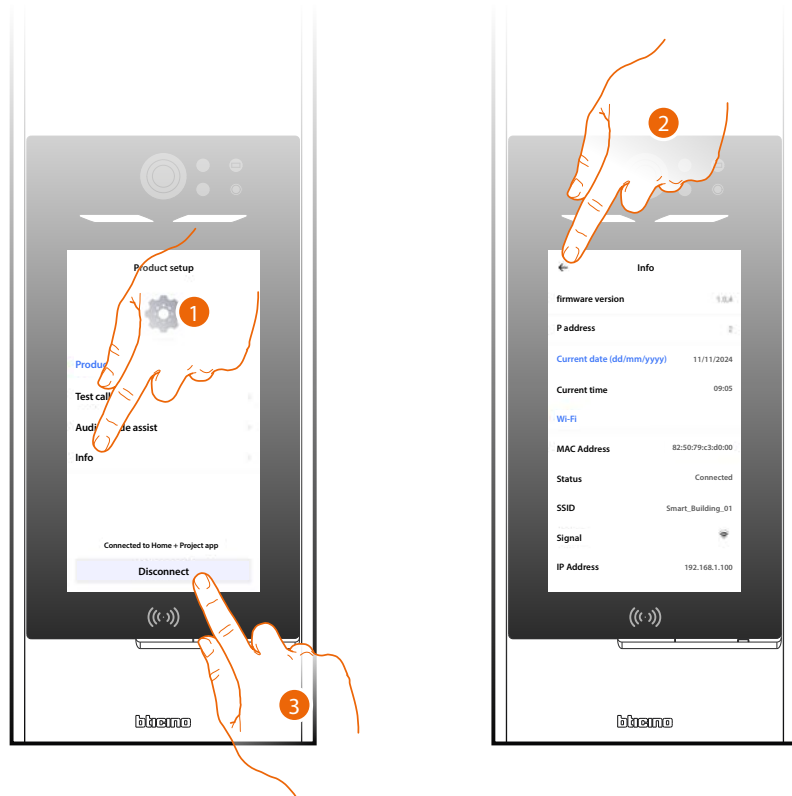

1. Touch to select the function:

Firmware version	Firmware version of the device
P address	SCS address of the device
Current date (gg/mm/aaa)	Current date
Current time	Current time
Wi-Fi	
MAC Address	Network data
Status	Wi-Fi connection status
SSID	Name of the Wi-Fi network to which the EP is connected
Signal	Signal level
IP Address	
Gateway	Network data
Network mask	
Server DNS	
Ethernet	
MAC Address	Network data
Status	Ethernet connection status
IP Address	
Network mask	Network data
Bluetooth	
MAC Address	Network data
Device name	Device name in the Bluetooth network

2. Touch to return to the previous page.

3. After displaying the data, touch to disconnect and return to the Home Page.

Reset

This function restores the factory values of the device.

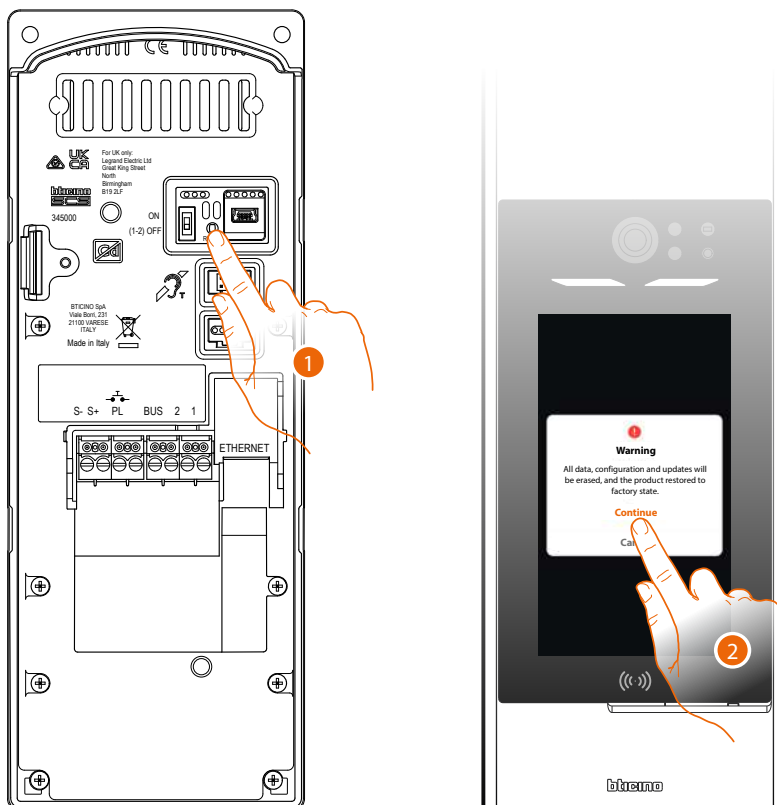

1. Press and hold down the reset pushbutton for 10 seconds.
CAUTION: all data, configurations and updates will be deleted.
2. Touch to continue.

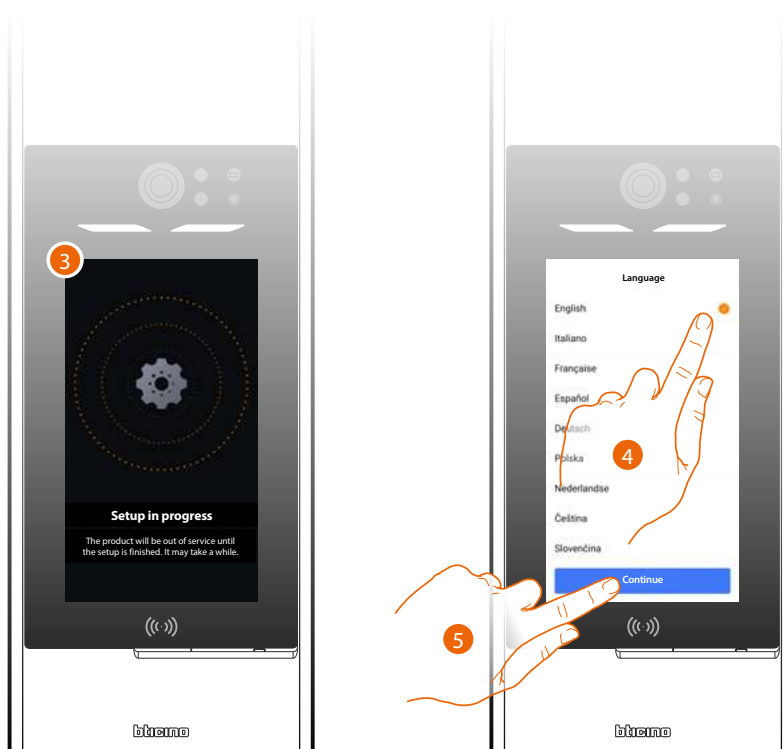

3. Wait for the procedure to be completed.
4. When finished, the language selection screen appears: select the language.
5. Touch to continue.

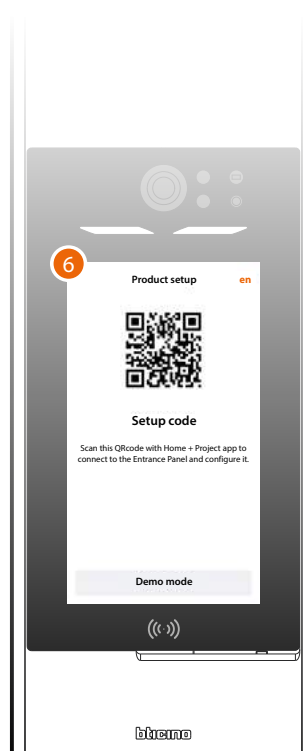

6. The connection screen showing Home + project appears; see [System creation and first configuration](#).

Home + Project desktop tool

The web pages can be used to perform several functions (system structure creation, device configuration, resident customisation) more conveniently and quickly from your office using a PC.

Another important function, **exclusive to the desktop version**, is the ability to quickly configure the address book with resident data, by importing and exporting previously compiled CSV files.

However, the desktop version has **some limitations**:

- Bluetooth connection with the devices is not possible: this can only be done using the App.
- Changes using the desktop are only possible if after activating the system at least one EP is connected to the internet.

These changes can only be performed and synchronised remotely if they fall into the category of changes that can be "Propagated" using the automatic procedure.

See [Fundamental concepts](#).

NOTE: to implement the configurations made in the Home + Project desktop tool, it is necessary to perform the [synchronisation](#) from the Home + Project app.

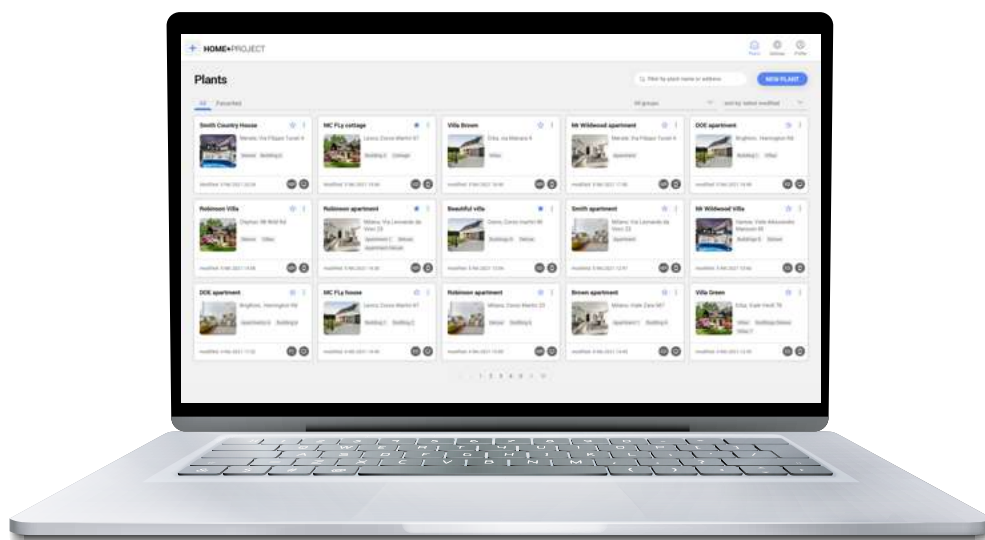

[Connect to the WEB pages](#)



BTicino SpA
Viale Borri, 231
21100 Varese
www.bticino.com
